

Series 285 Butterfly Valves

Advanced Angle-disc Design:

Provides bi-directional, positive shutoff and long service life.



Series
M285



Series 285 butterfly valves provide bi-directional, positive shutoff to ANSI 150 standards (285 psig). They feature an exclusive angle disc with a 360° uninterrupted differential sealing surface.

Series 285 butterfly valves offer outstanding flow efficiency, with a rigid-drive, precision disc-to-shaft connection that eliminates load-bearing fasteners in the flowstream. Double-shaft seals and shaft bushings assure smooth, low-torque operation.

Available in both resilient-seated and metal-lined configurations, Series 285 butterfly valves have a non-wetted body and may be specified in lug or wafer designs. They are used with a variety of pneumatic, electric and hydraulic actuation.

Features

- 100% bubble-tight positive shutoff
- Full rated bi-directional shutoff
- Field replaceable resilient seat
- Non-wetted body design
- Wide selection of materials available
- Meets ANSI B16.5 code for Class 150 flange pressure/temperature rating
- Sizes 2½" through 36"

Contents

- 2** Series R285 Benefits
- 4** Series R285 Parts
- 5** Series M285 Benefits
- 7** Series M285 Parts
- 8** Series 285A
2½"-12" Dimensions
- 9** Series 285A
14"-36" Dimensions
- 10** Series 285B
2½"-12" Dimensions
- 11** Series 285B
14"-36" Dimensions
- 12** Operating Torques
- 13** Series R&M 285
Model Code

NORRIS
PRODUCTION SOLUTIONS

A DOVER COMPANY

NORRIS SEAL™
A DOVER COMPANY

**Engineered
Performance**

The Series R285 is the lowest priced long-life butterfly valve with a pressure/temperature rating that meets ANSI B16.5 for class 150 flanges.

Lowest Price Because It Is Completely Lined

The flow stream never touches the body. There is no need for a costly high-alloy body, even in corrosive service. The removable elastomer seat is easily replaced onsite in minutes.

Positive Shutoff With Norriseal Angle-Disc Design

The Series R285 is proven by over 30 years of day-in, day-out service. The disc does not seat in shaft holes, assuring bubble-tight shutoff with no scrubbing or compression set in the shaft hole area. Resilient seats are made from high-density elastomers which are highly resistant to deterioration by flow media.

Usage Between ANSI B16.5 Class 150 WELDNECK Flanges

The schedule 40 inside diameter of the flange is needed to provide proper seat support at the higher working pressure (200 psi and greater).

Flange Gaskets Are Not Required

Separate, replaceable body O-ring flange seals eliminate the need for flange gaskets. Flange seals can be changed, if necessary, without dismantling the valve and replacing the seat. Often a damaged flanged seal need not be replaced, but simply turned over and inserted back into the body face groove.

No Need for Scheduled Lubrication

Four O-ring shaft seals lock in factory lubricant. Along with the primary seal molded into the elastomer seat shaft hole, these seals provide protection against leakage into body shaft bearing areas.

Four self-lubricated, steel-backed shaft bushings reduce operating torque and prevent galling of the shaft. Bushings are designed to operate above temperature limits of elastomer seats and seals with a 2 to 1 safety factor at full differential pressure.

Greater Flow Efficiency and Lower Operating Torque

The Series R285 butterfly valve gives you much greater flow efficiency and lower operating torque than conventional offset disc valves which meet pressure/temperature requirements of ANSI B16.5 code for class 150 flanges.

Bi-directional Flow With No Loss in Flow Efficiency

The symmetrical disc design of Norriseal angle-disc valves gives you the same highly efficient flow in both directions. Since the flow area is equal on both sides of the thru-shaft, no unbalanced flow occurs as is experienced in conventional offset disc designs.

Reserve Strength to Handle Sudden Differential Pressure Surges

The Series R285 butterfly valve provides a 285 psi rating and insures added protection against water-hammer and other unexpected overloads. Every valve is strength tested before shipment and is shell tested to 150% (430 psig) of rated pressure with the disc open. Every valve is tested for positive shutoff – differentially tested to 110% (315 psig) of rated working pressure with the disc closed. Every valve is tested for leakage into the shaft bearing area. The set screw is removed during differential and shell testing to assure that there is no leakage into this area.

Added Strength With a Thru-Shaft

A high-strength, full-length shaft is cross-pinned to the disc with a large-diameter solid, round pin, which is field removable. This connection is stronger than the torsional strength of the shaft itself. The disc pin does not penetrate the sealing surface of the disc. Shafts are manufactured from premium performance material: 17-4PH stainless, K-Monel.

Each Disc Is Individually Centered to Prevent Leakage

Precision thrust bearings keep the disc in precisely centered alignment with the seat, assuring reliable, bubble-tight seating throughout the life of the valve and helping to prevent leakage through the valve bore.

Self-Cleaning Valves

Smooth disc contours resist dirt build-up and turbulence.

Choice of Actuators

All actuators fitting Norriseal 200 psi models also fit the R285 Series – lever handles, gear operators, diaphragm actuators, air cylinder assemblies and electric operators.

Compare the R285 series with the valves you're using now, then call for our application engineering department. We'll fill you in on all the Norriseal money saving angles and help you select a R Series valve for your next application.

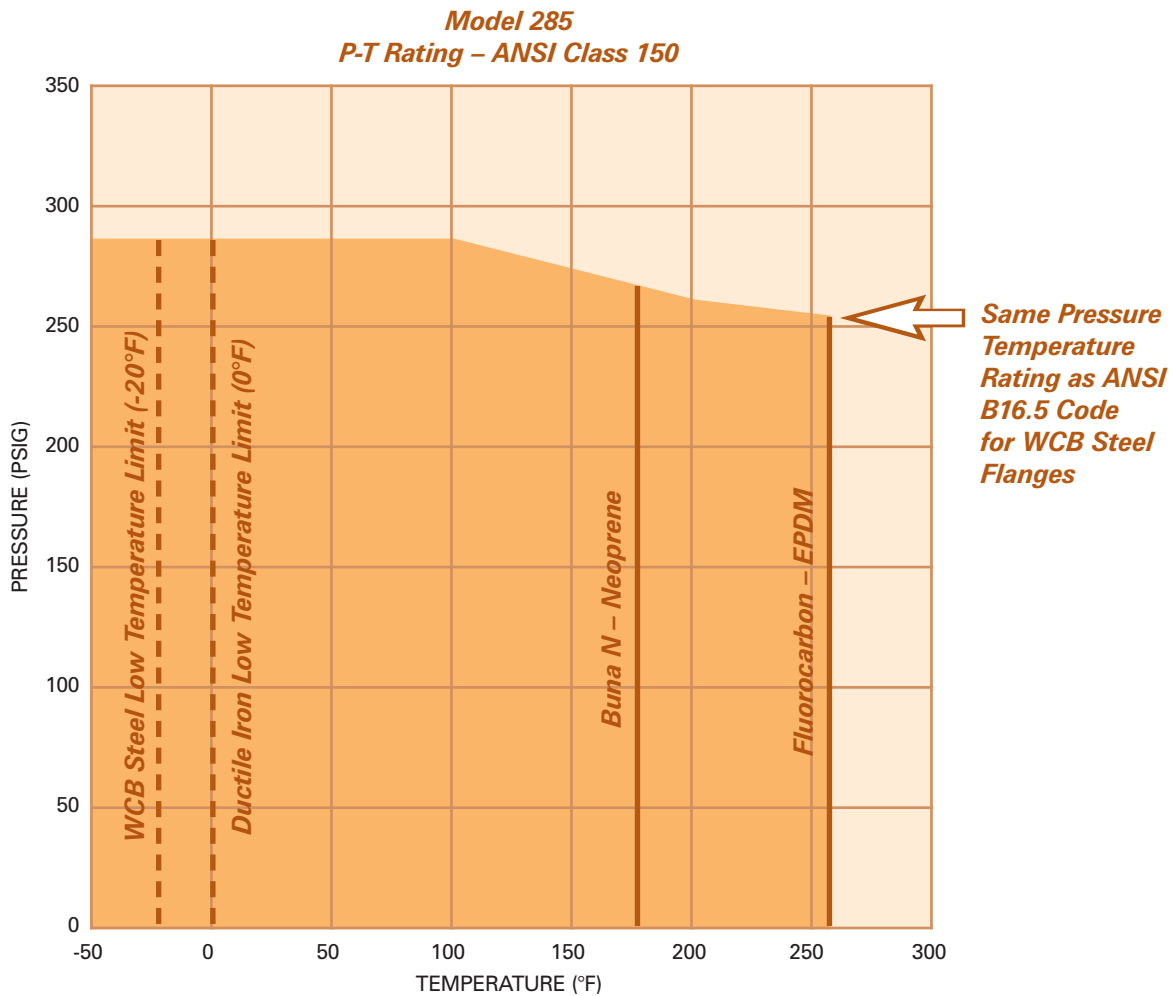

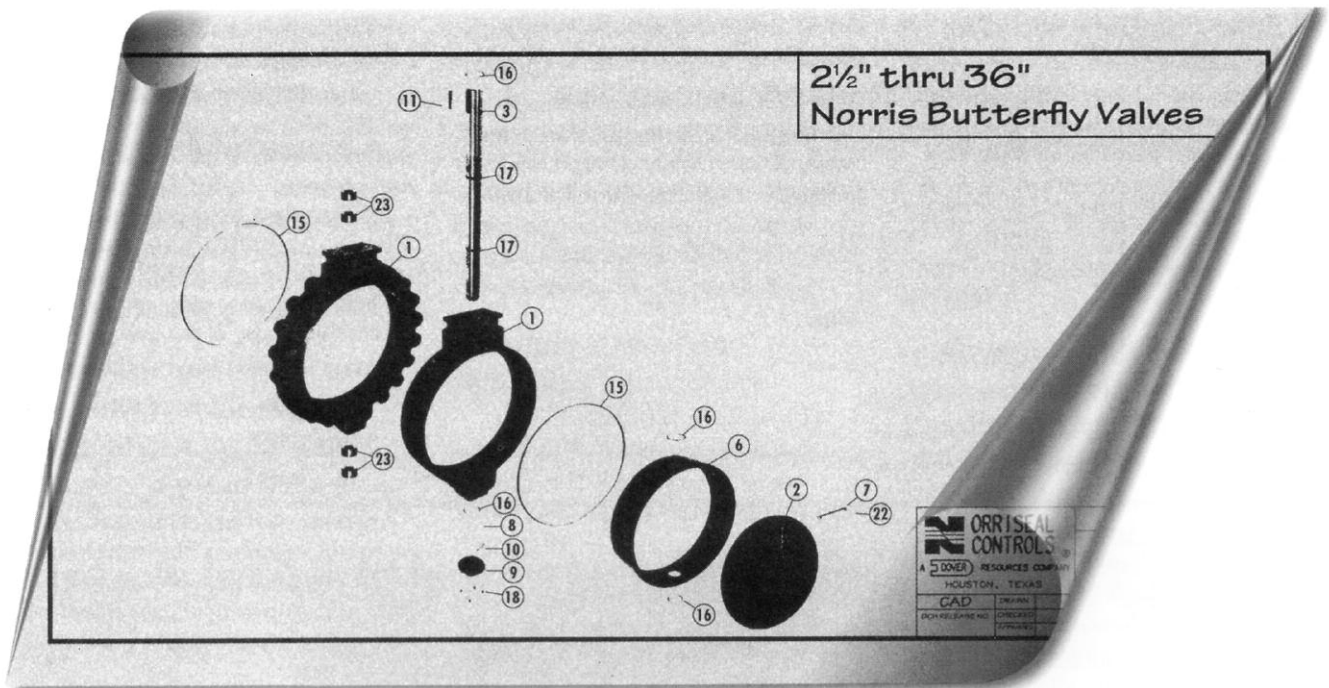

Parts Description

- 1 Body.** Valve body is isolated from flow stream by resilient seat and O-ring seals. Bodies have shaft bushings for handling shaft loads and to provide minimum operating torque.
- 2 Disc.** Angle disc construction gives 360° uninterrupted contact of disc with seat. Disc does not seat in shaft holes, assuring bubble-tight shutoff time after time with no scrubbing of the elastomer in the shaft hole areas.
- 3 Shaft.** Through shaft, cross pinned to disc with straight dowel pin, assures maximum drive strength and field repairability. Disc does not penetrate the sealing plane of the disc.
- 6 Seat.** Field replaceable resilient seat is bonded to a rigid backing ring to prevent seat from distorting or collapsing due to high velocity flow or in vacuum service. Rigid backing also prevents seat collapse during installation of valve between flanges.
- 7 Disc Pin.** Round pin does not penetrate the sealing plane of the disc.
- 8. Shim Set.** Assures proper support and centering of disc in seating area.
- 9-10 Thrust Plate & Washer.** Retains shaft from bottom.
- 11 Key.** Provides precision fit with operator (14" & larger)
- 15 Body O-rings.** Body O-ring flange seals eliminate need for flange gaskets. Flange seals can be replaced without dismantling the valve and replacing the seat. Many times, an O-ring flange seal damaged during initial installation may still be used simply by turning it over and returning it to the body.
- 16 O-ring Seat and Shaft Seals.** Seat and shaft seals prevent stem leakage to atmosphere and permanently lubricated areas; protect from outside contamination.
- 17 O-ring Disc/Shaft Seals.** Seals prevent leakage across disc plane.
- 18 Thrust Plate Capscrews.** To retain bottom thrust plate. (not shown)
- 22 Disc Pin Capscrews.** To retain disc pin. (not shown)
- 23 Shaft Bushings.** Self-lubricated steel-backed shaft bushings reduce operating torque and prevent galling of the shaft.

Reserve Strength to Handle Sudden Differential Pressure Surges

The Series M285 butterfly valve provides a 285 psi rating and insures added protection against water-hammer and other unexpected overloads.

Strength Tested

Shell tested to 150% (430 psig) of rated pressure with the disc open, hydrostatically tested for bi-directional positive shutoff without leakage at 110% (315 psig) of rated working pressure, and tested for absence of leakage into the shaft bearing areas, only valves that meet all of these POSITIVE SHUTOFF standards are approved for shipment.

Longer Life

Series 285 butterfly valves provide long service life because an almost unlimited combination of trim materials for the disc, liner and O-ring seals is available to control even the most destructive flow streams. Any elastomer available in standard O-ring form can be used for sealing M285 valves.

Flow Stream Never Touches the Body

Shaft O-ring seals and a field-replaceable metal seat keep the body dry.

Bi-directional Flow With No Loss in Flow Efficiency

The flow area is equal on both sides of the thru-shaft with Norriseal's symmetrical angle-disc design. There is less turbulence and reduced fluid dynamic torque than in "high-performance" butterfly valves with offset discs.

The redesigned, bi-directional disc O-ring groove (patent applied for) assures positive shutoff in both directions.

Easy On-site Maintenance

No special tools are required and maintenance takes only minutes. Replacing a part will not affect positive shutoff characteristics of the valve.

No Need for Scheduled Lubrication

The shaft is factory lubricated and protected against leakage by four O-ring seals. Four self-lubricated, steel-backed shaft bushings reduce operating torque and prevent galling of the shaft.

No Flange Gaskets Required

Separate body O-ring flange seals are replaceable in minutes without dismantling the valve.

A Choice of Actuators

Actuator options include lever handles, gear operators, diaphragm actuators, cam-operated cylinder assemblies, and electric operators.

Norriseal M285 valves are intended for use between ANSI B16.5 class 150 flanges.

Application Engineering Assistance

Call 1-713-466-3552 for help in selecting the correct Norriseal M285 valve for each application.

For Chemical Industries

Norriseal valves with stainless steel, Monel, Hastelloy, or nickel aluminum bronze discs and seats and Viton®, Buna N, EPDM, or Neoprene seals solve difficult valving problems in the chemical processing industry – without repairs – over long service periods.

Now In Aviation Fueling Systems Nationwide

M285 valves are ideal for handling volatile materials such as gasolines, jet fuels and solvents, which tend to dry elastomers.

Features

- Metal-lined positive shutoff
- Non-wetted body design
- Full bi-directional shutoff
- Wide selection of materials available

For Marine Service

For many years, Norriseal valves have met U.S. Navy specifications for services such as bilge, ballast, fire mains, etc. They also satisfy MIL-V-16468 for positive shutoff of hydrocarbon fuels on shipboard.

During the 1970s, in fire tests by the U.S. Coast Guard, Norriseal valves satisfactorily handled flammable liquids in a fire situation. The Coast Guard has qualified Norriseal metal-lined valves for critical positive shutoff services on shipboard according to paragraph 56.50-60.

For the Petroleum Industry

M-Series valves meet the many requirements on loading racks and manifolds, in tank farms and in distribution systems.

They are approved for control of poisonous hydrogen sulfide gas and other services near the wellhead.

M-Series Valves Meet Industry Standards Around the World

Norriseal M-Series split-shaft valves were the first butterfly valves to be approved under U.S. Navy specifications MIL-V16468, which covers positive shutoff valves for hydrocarbon service on shipboard.

Norriseal M-Series valves also meet the following standards:

Commercial Marine Certificates. U.S. Coast Marine Engineering Regulations, subchapter F (CG-115) and 46 DFT 56.50-60 (d); American Bureau of Shipping Rules for the Classifications and Construction of Steel Vessels.

Commercial Marine Compliance. Det Norske Veritas (DNV); Lloyd's Register of Shipping.

Industrial Butterfly Valve Standards. MSS Standard Practice SP-67 Butterfly Valves; American Petroleum Institute – Refinery Division (API) Standard 609 Valve Body Dimensions and Pressure-Temperature Rating for Butterfly Valves;

Piping Standards Which Influence Valve Selection. American National Standards Institute (ANSI) – Standards for Flanges and Fittings – B16.5 Code for Pressure/Temperature Rating of Class 150 Flanges; Deutsches Institut for Normung e.V. (DIN) – Standards for Flanges; Japanese Industrial Standards (JIS) – Flange Standards; British Standards Institute (BSI) – Flange Standards

Special drilling or notching of Norriseal valves is required for use with DIN, JIS and BSI flanges. Consult factory for details.

*Model 285
P-T Rating – ANSI Class 150 M-Series*

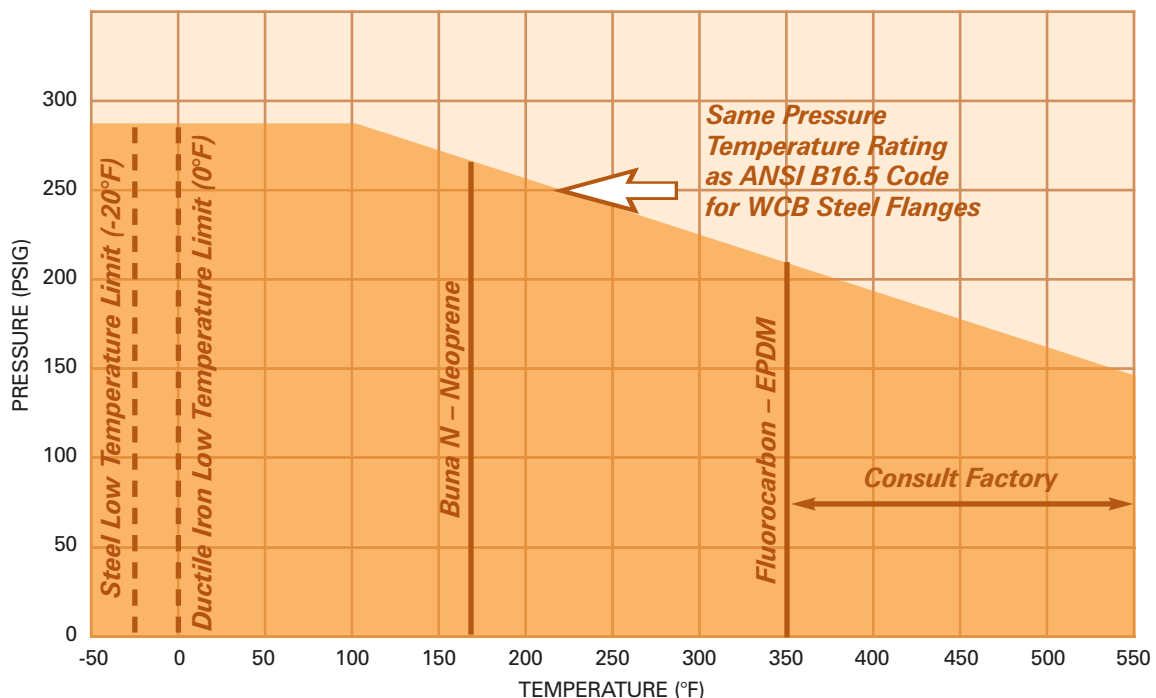

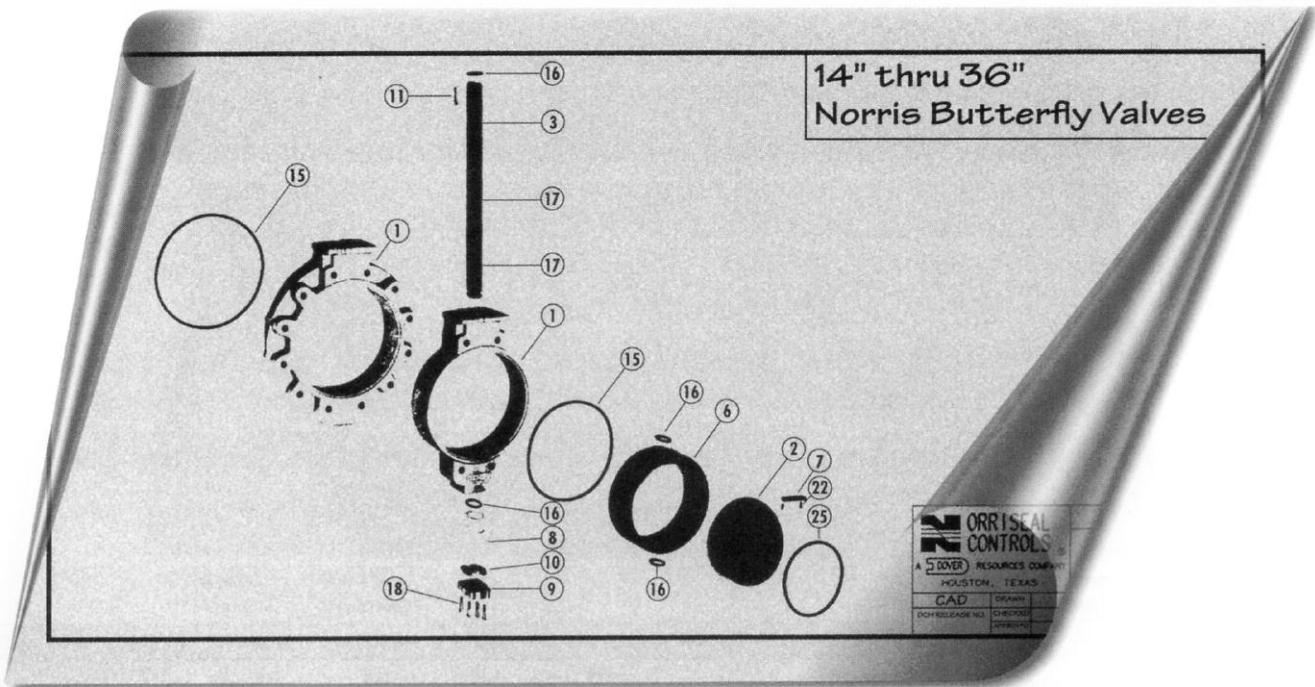

Parts Description

- 1 Body.** Available in wafer and lug type.
- 2 Disc.** Angle-disc construction gives 360° uninterrupted contact of disc O-ring seal with metal liner for dependable positive shutoff.
- 3/7 Shaft/Disc Pin.** Through shaft is cross pinned to disc with large diameter solid straight pin, assuring disc/shaft/pin interchangeability. Disc pin does not penetrate sealing plane of the disc – it is positively retained with two capscrews.
- 6 Seat.** Field-replaceable metal seat isolates valve body from flow stream; eliminates need for premium body material even when handling corrosive media.
- 8 Shim Set.** Assures proper disc/seat support and perfectly centers disc in seating area for positive shutoff throughout the life of the valve.
- 9/10 Thrust Plate & Washer.** Retains shaft from bottom.
- 11 Key.** Provides precision fit with operator (14" & larger). Double key slot is standard so valve action is easily reversed. (Not shown).
- 15 Body O-rings.** Body O-ring flange seals eliminate need for flange gaskets. Flange seals can be replaced without dismantling the valve.
- 16 O-ring Seat and Shaft Seals.** Double shaft/bushing seals prevent stem leakage and protect from internal or external contamination. Internal seals are 100% tested to assure there is no leakage behind the seat.
- 17 O-ring Disc/Shaft Seals.** Double seals prevent leakage thru disc/shaft hole.
- 18 Thrust Plate Capscrews.** Retain bottom thrust plate.
- 22 Disc Pin Capscrews.** Retain disc pin. Stainless steel or K-Monel.
- 23 Shaft Bushings.** Self-lubricated steel-backed shaft bushings reduce operating torque and prevent galling of the shaft.
- 25 Disc O-ring Seal.** O-ring contained in specially designed groove in disc edge (patent applied for) assures bi-directional positive shutoff.

R285A 2½"-12" Valves Certified Dimensions

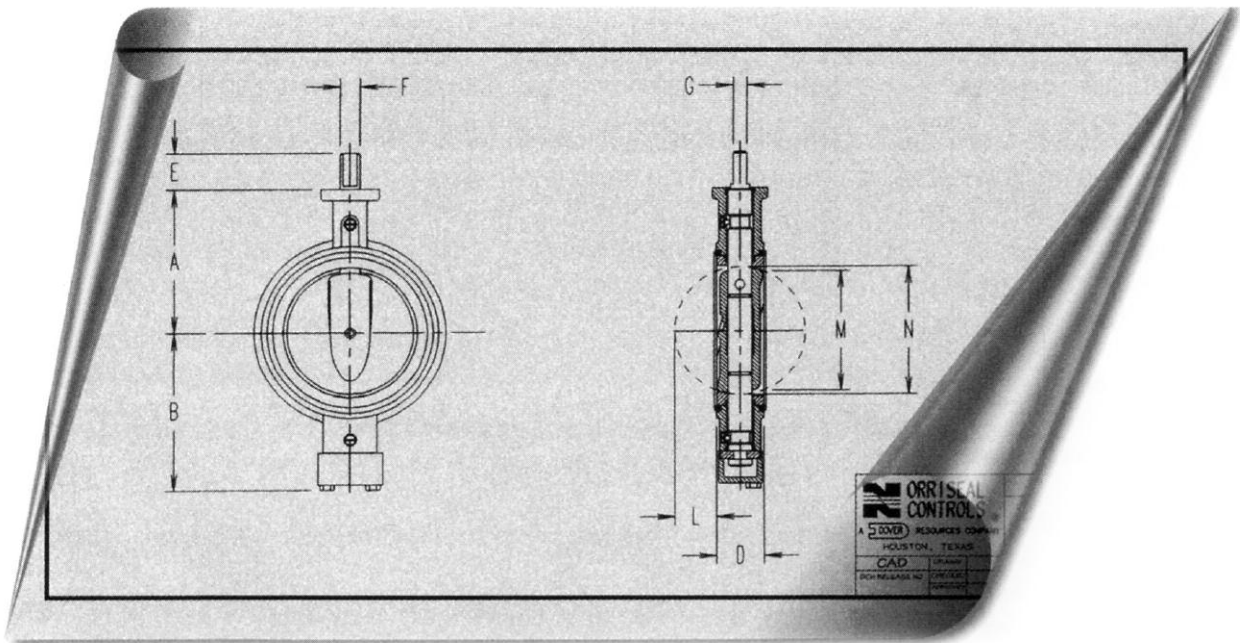

VALVE DIMENSIONS

Dimension Reference	Valve Size (Inches/mm)								
	2.5/65	3/80	3.5/90	4/100	5/125	6/150	8/200	10/250	12/300
A	4.16	4.41	N/A	4.88	5.28	6.50	7.47	9.38	10.41
B	4.48	4.86	N/A	5.31	5.72	7.27	8.22	9.92	10.96
C	4.88	5.38	N/A	6.88	7.75	8.75	10.88	13.38	16.00
D	1.75	1.75	N/A	2.00	2.13	2.13	2.50	2.50	3.00
E	1.31	1.31	N/A	1.31	1.31	1.69	1.69	2.00	2.00
F	.69	.69	N/A	.69	.69	.88	.88	1.06	1.06
G	.50	.50	N/A	.50	.50	.63	.63	.75	.75
H	.88	.88	N/A	.88	.88	1.06	1.06	1.38	1.38
J	.25	.25	N/A	.25	.25	.38	.38	.38	.38
K	1.81	1.81	N/A	1.81	1.81	2.34	2.34	2.63	2.63

DISC CLEARANCE

L	.50	.75	N/A	1.13	1.56	1.94	2.69	3.75	4.50
M	2.06	2.69	N/A	3.59	4.72	5.55	7.44	9.58	11.52
N	2.72	3.20	N/A	4.19	5.17	5.91	7.81	9.89	11.89
Approx Wt. Cast Iron Body	6	7	-	11	14	18	30	47	64

BOLT DATA

For Use with ANSI Class 150 Weldneck Flanges. For optimum valve performance, it is recommended that butterfly valves be installed between weldneck flanges or flanges with equivalent inside dimensions.									
Bolt Size	.63 x 4.50	.63 x 4.50	N/A	.63 x 4.50	.75 x 5.50	.75 x 6.00	.75 x 6.00	.88 x 6.00	.88 x 7.00
No. Required	4	4	-	8	8	8	8	12	12

OPERATOR DIMENSIONS

P	9.94	9.94	N/A	9.94	9.94	15.00	15.00	16.00	16.00
Q	3.34	3.34	N/A	3.34	3.34	3.66	3.66	3.66	3.66
R	6.88	6.88	N/A	6.88	6.88	7.50	7.50	8.00	8.00
S	6.00	6.00	N/A	6.00	6.00	8.00	8.00	8.00	8.00
T	2.36	2.36	N/A	2.36	2.36	2.36	2.36	3.00	3.00
U	3.50	3.50	N/A	3.50	3.50	3.50	3.50	4.38	4.38
V	5.93	5.93	N/A	5.93	5.93	5.93	5.93	7.50	7.50
W	5.25	5.25	N/A	5.25	5.25	5.25	5.25	6.75	6.75
X	2.92	2.92	N/A	2.92	2.92	2.92	2.92	3.27	3.27
Y	2.63	2.63	N/A	2.63	2.63	2.63	2.63	2.63	2.63
Z	1.69	1.69	N/A	1.69	1.69	1.69	1.69	1.88	1.88
Aprox Wt. 2R & 2RM Operator	7	7	N/A	7	7	8	8	13	13

R285A 14"-36" Valves Certified Dimensions

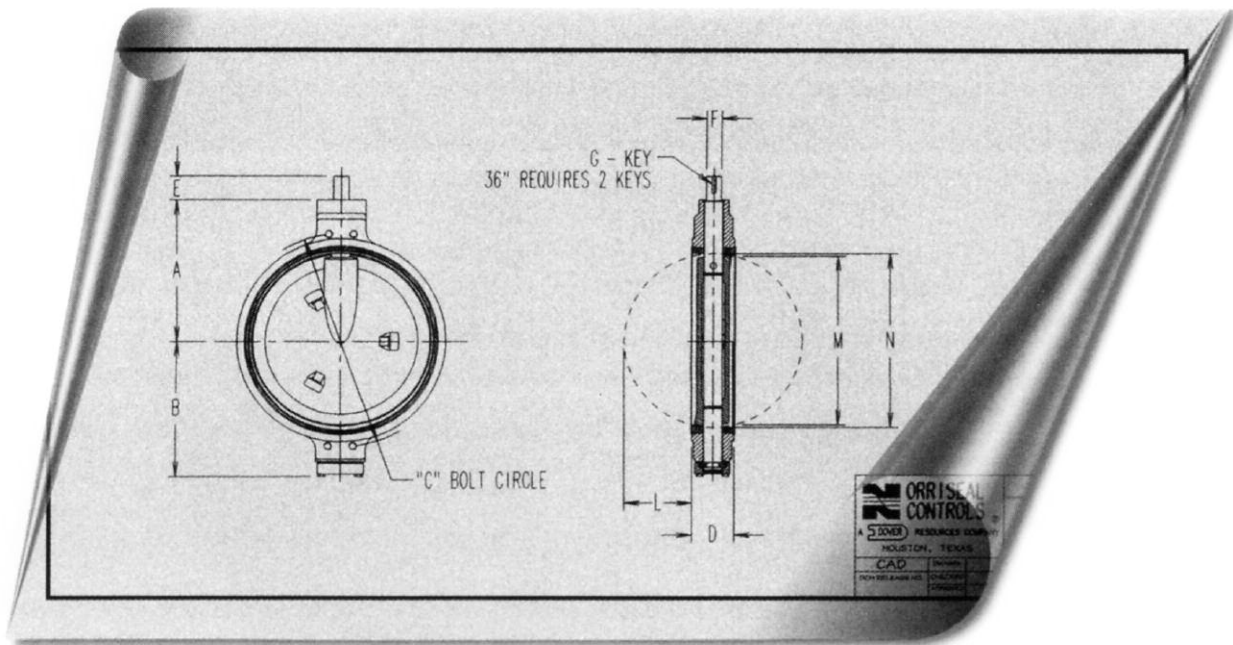

VALVE DIMENSIONS

Dimension Reference	Valve Size (Inches/mm)										
	14/350	16/400	18/450	20/500	22/550	24/600	26/650	28/700	30/750	32/800	36/900
A	12.63	14.00	14.75	16.00	17.38	17.50	20.13	22.75	23.75	24.50	26.13
B	14.25	15.63	16.63	17.88	18.00	19.00	20.61	21.83	22.70	24.23	29.38
C	18.75	21.25	22.75	25.00	27.25	29.50	31.75	34.00	36.00	38.50	42.75
D	3.75	4.13	4.63	5.13	5.00	5.00	6.00	6.50	7.00	7.00	8.50
E	3.94	3.94	3.94	3.94	3.94	3.94	3.94	3.94	3.94	3.94	4.75
F	1.75	1.75	1.75	2.50	2.50	2.50	2.50	2.50	2.50	2.50	3.00
G	.38x2.5	.38x2.5	.38x2.5	.63x2.94	.63x2.94	.63x2.94	.63x2.94	.63x2.94	.63x2.94	.63x2.94	.75x3.0
H	1.75	2.00	2.25	2.50	2.50	2.50	3.00	3.00	3.00	3.50	3.50
J	.63	.63	.63	.63	.63	.63	.75	.75	.75	.75	.75
K	1.50	1.50	1.50	1.50	1.50	1.50	1.50	1.50	1.50	1.50	1.50

DISC CLEARANCE

L	4.79	5.61	6.36	7.14	8.19	9.19	9.60	10.36	11.10	11.96	12.88
M	12.80	14.78	16.72	18.72	20.75	22.83	24.50	26.38	28.50	30.13	34.25
N	13.34	15.34	17.34	19.41	21.33	23.38	25.51	27.21	29.21	30.96	35.25
Approx Wt.- Cast Iron Body	160	224	300	370	420	518	640	740	940	990	1485

BOLT DATA

For Use with ANSI Class 150 Weldneck Flanges.
For optimum valve performance, it is recommended that butterfly valves be installed between weldneck flanges or flanges with equivalent inside dimensions.

Bolt Size	1.00x 7.75	1.00x 8.50	1.13 x 9.00	1.13x10.00	1.25x11.50	1.25x11.50	1.25x13.00	1.25x13.50	1.25x14.00	1.50x14.00	1.50x15.00
No. Required (Both Required)	8	12	12	16	16	16	20	24	24	24	28
Capscrew Size	1.00NC x 3.00	1.00NC x 3.00	1.13 NC x 3.00	1.13 NC x 3.00	1.25 NC x 3.50	1.25 NC x 4.00	1.25 NC x 3.50	1.25 NC x 3.25	1.25 NC x 3.50	1.50 NC x 3.75	1.50 NC x 3.75
No. Required	8	8	8	8	8	8	8	8	8	8	8

OPERATOR DIMENSIONS

R	9.75	9.75	9.75	17.25	17.25	17.25	17.84	17.84	17.84	17.84	17.84
S	12.75	12.75	12.75	24.00	24.00	24.00	24.00	24.00	24.00	24.00	24.00
T	4.83	4.83	4.83	5.38	5.38	5.38	2.69	2.69	2.69	2.69	7.13
U	6.63	6.63	6.63	7.63	7.63	7.63	9.44	9.44	9.44	9.44	10.81
V	10.13	10.13	10.13	11.13	11.13	11.13	14.94	14.94	14.94	14.94	16.31
W	9.00	9.00	9.00	10.81	10.81	10.81	12.00	12.00	12.00	12.00	14.00
X	5.00	5.00	5.00	5.14	5.14	5.14	7.38	7.38	7.38	7.38	7.75
Y	4.50	4.50	4.50	N/A	N/A	N/A	N/A	N/A	N/A	N/A	N/A
Z	2.88	2.88	2.88	2.88	2.88	2.88	4.00	4.00	4.00	4.00	4.00
Approx Wt. 2T & 2TM Operator	70	70	70	90	90	90	90	210	210	210	260

R285B 2½"-12" Valves Certified Dimensions

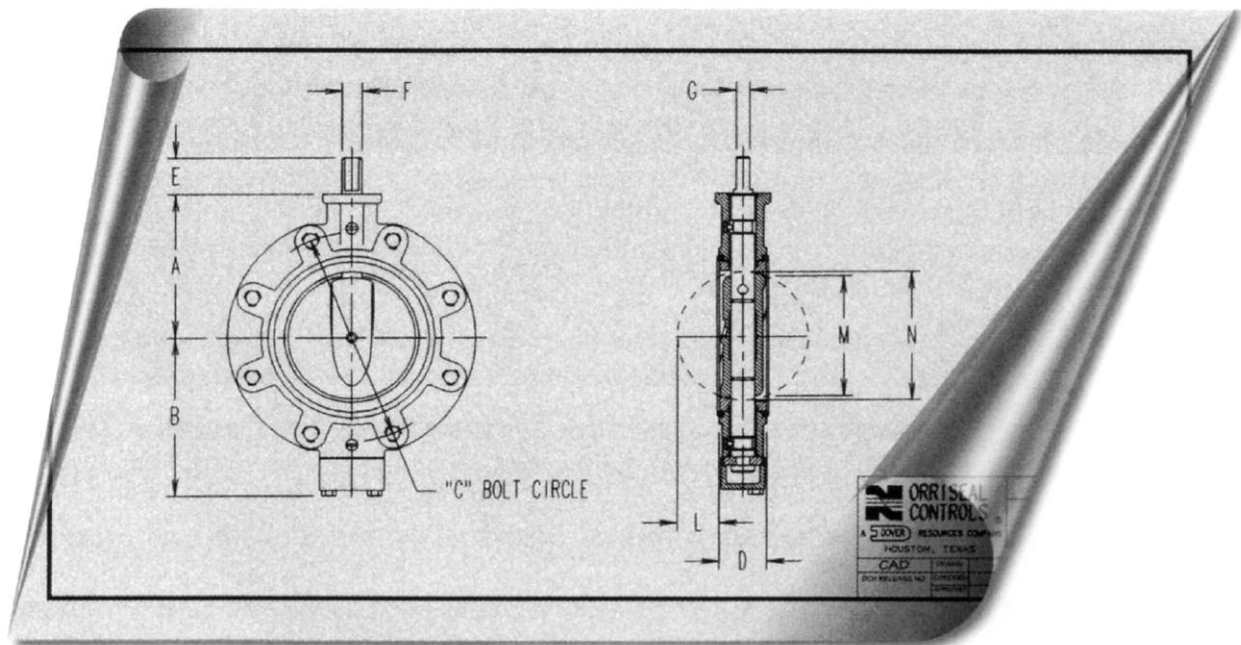

VALVE DIMENSIONS

Dimension Reference	Valve Size (Inches/mm)								
	2.5/65	3/80	3.5/90	4/100	5/125	6/150	8/200	10/250	12/300
A	4.16	4.41	4.63	4.88	5.28	6.50	7.47	9.38	10.41
B	4.48	4.86		5.31	5.72	7.27	8.22	9.92	10.96
C	5.50	6.00	7.00	7.50	8.50	9.50	11.75	14.25	17.00
D	1.75	1.75	1.94	2.00	2.13	2.13	2.50	2.50	3.00
E	1.31	1.31	1.31	1.31	1.31	1.69	1.69	2.00	2.00
F	.69	.69	.69	.69	.69	.88	.88	1.06	1.06
G	.50	.50	.50	.50	.50	.63	.63	.75	.75
H	.88	.88	.88	.88	.88	1.06	1.06	1.38	1.38
J	.25	.25	.25	.25	.25	.38	.38	.38	.38
K	1.81	1.81	1.81	1.81	1.81	2.34	2.34	2.63	2.63

DISC CLEARANCE

L	.50	.75	.94	1.13	1.56	1.94	2.69	3.75	4.50
M	2.06	2.69	3.16	3.59	4.72	5.55	7.44	9.58	11.52
N	2.72	3.20	3.72	4.19	5.17	5.91	7.81	9.89	11.89
Approx Wt. - Cast Iron Body	8	10	12	16	20	26	40	62	87

BOLT DATA

For Use with ANSI Class 150 Weldneck Flanges. For optimum valve performance, it is recommended that butterfly valves be installed between weldneck flanges or flanges with equivalent inside dimensions.									
Capscrew Size*	.63NC x 1.50	.63NC x 1.75	.63NC x 1.75	.63NC x 1.75	.75NC x 1.75	.75NC x 2.00	.75NC x 2.25	.88NC x 2.25	.88NC x 2.50
No. Required	8	8	16	16	16	16	16	24	24

OPERATOR DIMENSIONS

P	9.94	9.94	N/A	9.94	9.94	15.00	15.00	16.00	16.00
Q	3.34	3.34	N/A	3.34	3.34	3.66	3.66	3.66	3.66
R	6.88	6.88	N/A	6.88	6.88	7.50	7.50	8.00	8.00
S	6.00	6.00	N/A	6.00	6.00	8.00	8.00	8.00	8.00
T	2.36	2.36	N/A	2.36	2.36	2.36	2.36	3.00	3.00
U	3.50	3.50	N/A	3.50	3.50	3.50	3.50	4.38	4.38
V	5.93	5.93	N/A	5.93	5.93	5.93	5.93	7.50	7.50
W	5.25	5.25	N/A	5.25	5.25	5.25	5.25	6.75	6.75
X	2.92	2.92	N/A	2.92	2.92	2.92	2.92	3.27	3.27
Y	2.63	2.63	N/A	2.63	2.63	2.63	2.63	2.63	2.63
Z	1.69	1.69	N/A	1.69	1.69	1.69	1.69	1.88	1.88
Aprox Wt. 2R & 2RM Operator	7	7	N/A	7	7	8	8	13	13

R285B 14"-36" Valves Certified Dimensions

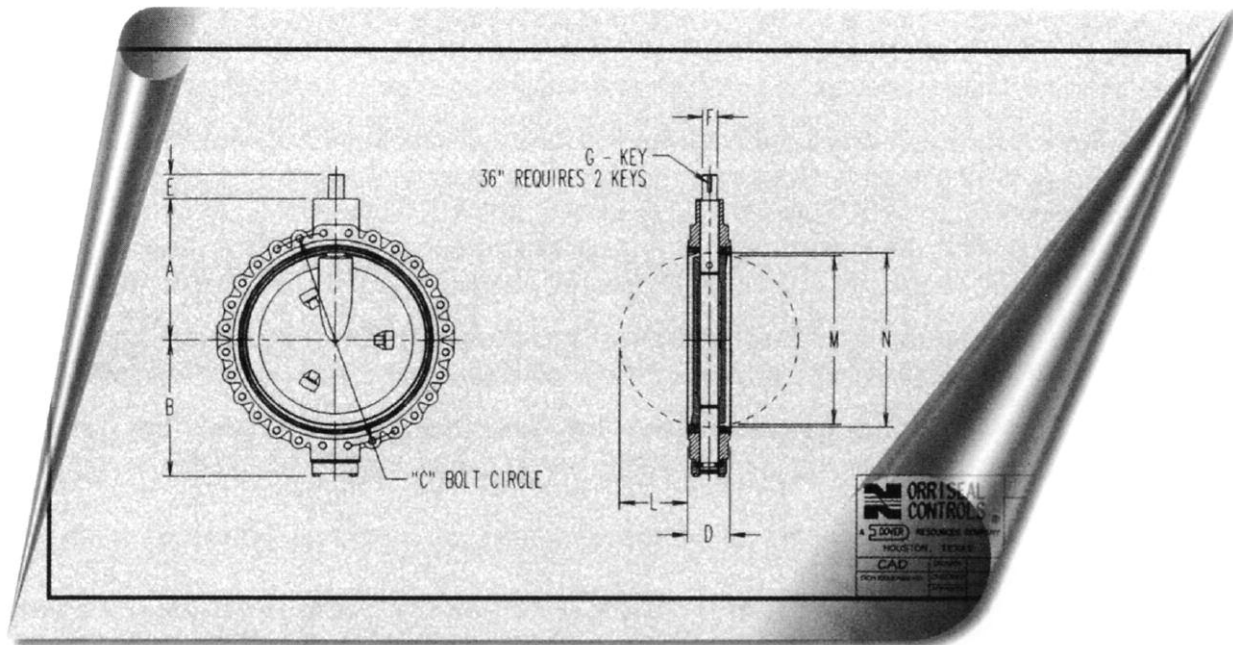

VALVE DIMENSIONS

Dimension Reference	Valve Size (Inches/mm)										
	14/350	16/400	18/450	20/500	22/550	24/600	26/650	28/700	30/750	32/800	36/900
A	12.63	14.00	14.75	16.00	17.38	17.50	20.13	22.75	23.75	24.50	26.13
B	14.25	15.63	16.63	17.88	18.00	19.00	20.61	21.83	22.70	24.23	29.38
C	18.75	21.25	22.75	25.00	27.25	29.50	31.75	34.00	36.00	38.50	42.75
D	3.75	4.13	4.63	5.13	5.00	5.00	6.00	6.50	7.00	7.00	8.50
E	3.94	3.94	3.94	3.94	3.94	3.94	3.94	3.94	3.94	3.94	4.75
F	1.75	1.75	1.75	2.50	2.50	2.50	2.50	2.50	2.50	2.50	3.00
G	.38x2.5	.38x2.5	.38x2.5	.63x2.94	.63x2.94	.63x2.94	.63x2.94	.63x2.94	.63x2.94	.63x2.94	.75x3.0
H	1.75	2.00	2.25	2.50	2.50	2.50	3.00	3.00	3.00	3.50	3.50
J	.63	.63	.63	.63	.63	.63	.75	.75	.75	.75	.75
K	1.50	1.50	1.50	1.50	1.50	1.50	1.50	1.50	1.50	1.50	1.50

DISC CLEARANCE

L	4.79	5.61	6.36	7.14	8.19	9.19	9.60	10.36	11.10	11.96	12.88
M	12.80	14.78	16.72	18.72	20.75	22.83	24.50	26.38	28.50	30.13	34.25
N	13.34	15.34	17.34	19.41	21.33	23.38	25.51	27.21	29.21	30.96	35.25
Approx Wt.- Cast Iron Body	200	290	370	460	485	531	810	980	1080	1130	1795

BOLT DATA

For Use with ANSI Class 150 Weldneck Flanges. For optimum valve performance, it is recommended that butterfly valves be installed between weldneck flanges or flanges with equivalent inside dimensions.											
Capscrew Size	1.00NCx3.00	1.00NCx3.00	1.13NCx3.50	1.13NCx3.50	1.25NCx4.00	1.25NCx4.00	1.25NCx4.00	1.25NCx4.00	1.25NCx4.00	1.50NCx4.50	1.50NCx4.50
No. Required (Both Required)	24	32	32	32	32	40	40	48	48	48	64
Capscrew Size				1.00NCx3.00	1.25NCx3.50		1.25NCx3.50	1.25NCx3.25	1.25NCx3.50	1.50NCx3.75	1.50NCx4.00
No. Required	N/A	N/A	N/A	8	8	N/A	8	8	8	8	8

OPERATOR DIMENSIONS

R	9.75	9.75	9.75	17.25	17.25	17.25	17.84	17.84	17.84	17.84	17.84
S	12.75	12.75	12.75	24.00	24.00	24.00	24.00	24.00	24.00	24.00	24.00
T	4.83	4.83	4.83	5.38	5.38	5.38	2.69	2.69	2.69	2.69	7.13
U	6.63	6.63	6.63	7.63	7.63	7.63	9.44	9.44	9.44	9.44	10.81
V	10.13	10.13	10.13	11.13	11.13	11.13	14.94	14.94	14.94	14.94	16.31
W	9.00	9.00	9.00	10.81	10.81	10.81	12.00	12.00	12.00	12.00	14.00
X	5.00	5.00	5.00	5.14	5.14	5.14	7.38	7.38	7.38	7.38	7.75
Y	4.50	4.50	4.50	N/A	N/A	N/A	N/A	N/A	N/A	N/A	N/A
Z	2.88	2.88	2.88	2.88	2.88	2.88	4.00	4.00	4.00	4.00	4.00
Approx Wt. 2T & 2TM Operator	70	70	70	90	90	90	90	210	210	210	260

Operating Torques

OPERATING TORQUES 285 SERIES (INCH-POUNDS)

Operating torques for wet service shown in table below include 50% service factor. For dry torques, multiply the values shown by 1.33.

Valve Size		R 285 – Wet Service						M 285 – Wet Service					
		Line Pressure – psi						Line Pressure – psi					
IN	MM	0	50	100	150	200	285	0	50	100	150	200	285
2.5	65	100	134	169	204	238	275	86	133	181	229	276	285
3	75	140	180	221	261	302	504	115	172	230	288	345	448
4	100	224	308	392	476	560	672	207	328	448	569	690	897
5	125	343	492	616	761	896	1,050	310	550	787	1,027	1,265	1,782
6	150	1,000	1,120	1,254	1,377	1,512	1,820	575	907	1,240	1,572	1,904	2,645
8	200	2,116	2,419	2,755	3,113	3,427	4,060	862	1,625	2,386	3,148	3,910	5,175
10	250	3,024	3,516	4,020	4,502	5,040	5,880	1,207	2,343	3,478	4,615	5,750	7,360
12	300	4,827	5,544	6,216	6,921	7,616	9,100	1,495	3,938	6,382	8,826	11,270	15,100
14	350	6,500	7,475	8,400	9,500	10,300	12,600	1,730	4,900	8,000	11,300	14,500	21,000
16	400	8,000	9,300	10,300	11,500	12,500	15,000	2,050	6,150	10,200	14,300	18,400	26,500
18	450	11,000	12,500	14,000	15,300	17,000	21,000	2,300	6,800	11,300	15,700	20,000	29,000
20	500	11,600	14,000	16,000	18,500	20,700	25,300	2,600	8,400	14,300	20,000	26,000	38,000
24	600	16,700	19,500	22,000	25,000	27,600	33,000	3,100	10,800	18,500	26,000	34,000	50,600
30	750	40,000	45,000	49,000	53,000	58,000	68,000	3,900	17,600	31,300	45,000	59,000	86,250
36	900	46,000	55,000	63,000	72,000	81,000	98,000	5,200	27,000	49,000	70,000	92,000	126,000

PRESSURE CLASS	
Class	Code
ANSI 150 Valve 285 PSI	285

SERIES	
Series	Code
Resilient Seat	R
Metal Seat	M

VALVE SIZE (IN INCHES)	
Size	Code
2.5" - 36"	2...36

BODY CONFIGURATION	
Configuration	Code
Single Rib	A
Full Lug	B
Double Rib	C
Single Rib Longneck (1400) Limited Availability	F
Full Lug Longneck	G
ISO Wafer Body (DI only)	H
ISO Lugged Body (DI only)	J

BODY MATERIALS	
Material Type	Code
Ductile Iron ASTM A395 60-40-18	1
Carbon Steel (WCB) ASTM A216 Gr. WCB	2
316 Stainless Steel ASTM A743 CF8M*	5
Nickel Aluminum Bronze ASTM B148 Alloy C95800	6

*Special Order - Consult Factory

SHAFT MATERIAL	
Material	Code
K-Monel (NiCuAl) Alloy QQ-N-286A*	6
17-4 PH Stainless Steel ASTM A564 Type 630	7
Special to be Described	0
Hastelloy "C" 276 ASTM B574 Alloy N10276	C

DISC MATERIAL	
Code	Materials
1	Ductile Iron ASTM A395 60-40-18
2	316 Stainless Steel ASTM A743 Gr. CF8M
3	Alloy 20 Stainless Steel ASTM A743 Gr. CN7M
4	Aluminum Bronze ASTM B148 Alloy C95400 2" thru 14" Aluminum Bronze ASTM B148 Alloy C95500 16" thru 36"
6	Monel 400 (Ni Cu Alloy) ASTM A494, M30C
C	Hastelloy "C" ASTM A494 CW 12-MW
P	Nickel Aluminum Bronze ASTM B148 Alloy C95800
0	Special to be Described

SEAT MATERIAL (R SERIES)	
Code	Seat
A	Nitrile (BUNA N)
B	Fluoroelastomer (Viton)
E	Neoprene (Black)
G	Neoprene (White)
J	Abrasion Resistant Nitrile
S	EPDM (Ethylene Propylene Rubber)
4	HSN (Highly Saturated Nitrile)
7	SBR (Styrene Buta Diene)
8	Nitrile, Peroxide Cured
X	Special to be Described

SEAT MATERIAL (M SERIES)	
Code	Seat
2	316 Stainless Steel ASTM A743 Gr. CF8M
3	Aluminum Bronze ASTM B148 Alloy C95300
5	Monel (Ni Cu Alloy) ASTM A494, M30C
7	Alloy 20 Stainless Steel ASTM A743 Gr. CN7M
C	Hastelloy "C" ASTM A494 CW 12MW
G	Nickel Aluminum Bronze ASTM B148 Alloy C95800
0	Special to be Described

4 M 285 B-166 A A-2R

SEALS	
Materials	Code
Buna N	A
Fluoroelastomer (Viton)	B
Neoprene (Black)	E
Neoprene (White)	G
AFLAS	R
EPDM (NORDEL)	S
Low Temp Neoprene	V
Kalrez	Y
Highly Saturated Nitrile (HSN)	4
SBR	7
Peroxide Cured Buna N	8

NORRISEAL OPERATORS					
Code	Manual Operators	Code	Mechanical Operators	Code	Diaphragm Operators
1A	(2.5-12) STD Handle with 1J Topworks	2E	(2.5-12) Gear - W.P. - Aluminum Bronze Marine Trim	**	
1F	(2.5-12) Squeeze Trigger 10 Pos	2ES	(2.5-12) 2E Subm. for Salt Water	2G11	(2.5-4) 35 SR Diaphragm
1FM	(2.5-12) 1F with Marine Trim	2R	(2.5-12) Gear Operator Aluminum Case	2G12	(2.5-4) 35 PB Diaphragm
1J	(2.5-12) STD Topworks On-Off	2T	(2.5-36) Gear Operator Cast Iron Case	2G13	(2.5-8) 70 SR Diaphragm
1AM	(2.5-12) STD Handle with 1JS Topworks	2RM	2R with Marine Trim	2G14	(2.5-8) 70 PB Diaphragm
1P	(2.5-8) Locking Topworks	2TM	2T with Marine Trim	2G15	(6-12) 180 SR Diaphragm
1Q	(2.5-8) 1P Topworks with STD Handle			2G16	(6-12) 180 PB Diaphragm
1JS	(2.5-8) STD On-Off Topworks, Stainless Steel			2G17	(12-20) 180 SR Diaphragm
				2G18	(12-20) 180 PB Diaphragm

**2G Numbers listed are Basic Numbers Only. Complete Actuator Model Number Must be Used when ordering.
SR-Spring Return. Specify Fail/Open or Fail/Closed.
PB-Pressure Balanced/Double Acting.

Please note: not all available options are shown.

This Page Intentionally Left Blank

This Page Intentionally Left Blank

Why you can depend on genuine Norriseal products

- In-house engineering and technical support
- In-depth applications experience
- Award-winning innovation and ongoing product development
- ISO 9001:2008 certified manufacturing
- Over five decades of industry service
- Compliance with all industry standards and specifications
- Responsive service and prompt delivery
- Field support available worldwide

Please contact your Norriseal representative for more details and assistance in specifying the optimal solution for your application.



Engineered Performance

11122 West Little York • Houston, Texas 77041

Tel: 713-466-3552 • Fax: 713-896-7386

www.norriseal.com