



# Mark 50 Series

## Self-Operated Back Pressure Regulators

The Mark 50 Sliding Gate Back Pressure Regulator is used to regulate upstream pressure at a predetermined setpoint. The spring in the Mark 50 holds the sliding gate seats in their normally closed position.

The upstream pressure is sensed beneath the diaphragm. **(A sensing line is required on sizes: 2-1/2", 3", and 4")**. As the upstream pressure exceeds the setpoint, pressure is exerted on the diaphragm which raises the stem to modulate the disc (the movable component of the sliding gate seat set) toward the open position. As the seats open, upstream pressure will be regulated to the required setpoint. A decrease in pressure relaxes the spring and diaphragm to move the seats toward the closed position.



### MARK 50 FEATURES

#### *This brochure includes the following Series:*

- **MK50:** a line of self-operating back pressure regulators designed with Jordan Valve's sliding gate seats.
- **MK51:** The MK51 features a larger diaphragm than a standard MK50 to provide even greater sensitivity and more accurate regulation of your required setpoint.
- **MK50QC:** The MK50QC features a "Quick Change" dome for simple range spring replacements. Ideal for facilities with multiple back pressure requirements as it is possible to stock one valve with several spare springs to cover a wide range of needs.
- **MK50H:** The MK50H features a handwheel that is mounted on the adjusting screw to allow easy setpoint changes.
- **MK50HP:** The MK50HP option is an elongated spring housing that features a large spring for high pressure setpoints up to 450 psi (31,03 bar).
- **MK50GP:** The MK50GP option is used in grain processing for starch cookers and other viscous services.
- **MK50CR:** The MK50CR option has a special spring housing for use if the valve is in cryogenic services.
- **MK501/502:** The MK501 and MK502 meet higher capacity requirements than standard back pressure regulators.

- **Sliding Gate Trim** — unique seat design for unsurpassed trim life and accuracy.
- **Jorcote Seat Coating** — ceramic composite for liquids, gases and especially steam. Very low friction with outstanding wear resistance and a temperature rating of up to 550°F (288°C). Steam tested to 1,000,000 cycles and still maintained Class IV leakage.
- **Jorlon Diaphragm** — extremely durable, virtually universally applicable up to 450°F. Tested without failure to over 1,000,000 full stroke cycles. Ideal for steam, gases and liquids. 316SST diaphragm applicable up to 550°F.
- **Straight-through Flow** — The flow is straight through the valve seats and body. Direction of the disc travel is perpendicular to the flow, not opposed to the direction of the flow. Thus, the flow does not unbalance the seats. The MK50 can use a wider range of its stroke to give accurate control; less offset and rangeability up to 20:1.
- **Quiet Operation** — typically 5-10 dB less than conventional globe style regulators. The disc and plate are always in contact, which eliminates chattering. Straight-through flow minimizes turbulence. Multiple orifices in the plate and disc divide the flow stream into smaller flow components.
- **Minimum Maintenance** — The MK50 sliding gate seats require no special tools for disassembly. The seats are pre-lapped at the factory and are self-lapping while in operation ensuring a continual tight shutoff.



Jordan Valve, a division of Richards Industries

3170 Wasson Road • Cincinnati, OH 45209  
513.533.5600 • 800.543.7311 • 513.871.0105 (f)  
info@richardsind.com • www.jordanvalve.com

# MARK 50 SELF-OPERATING BACK PRESSURE REGULATORS

## Mark 50 Series

Ideal for gas and liquids  
Superior for steam

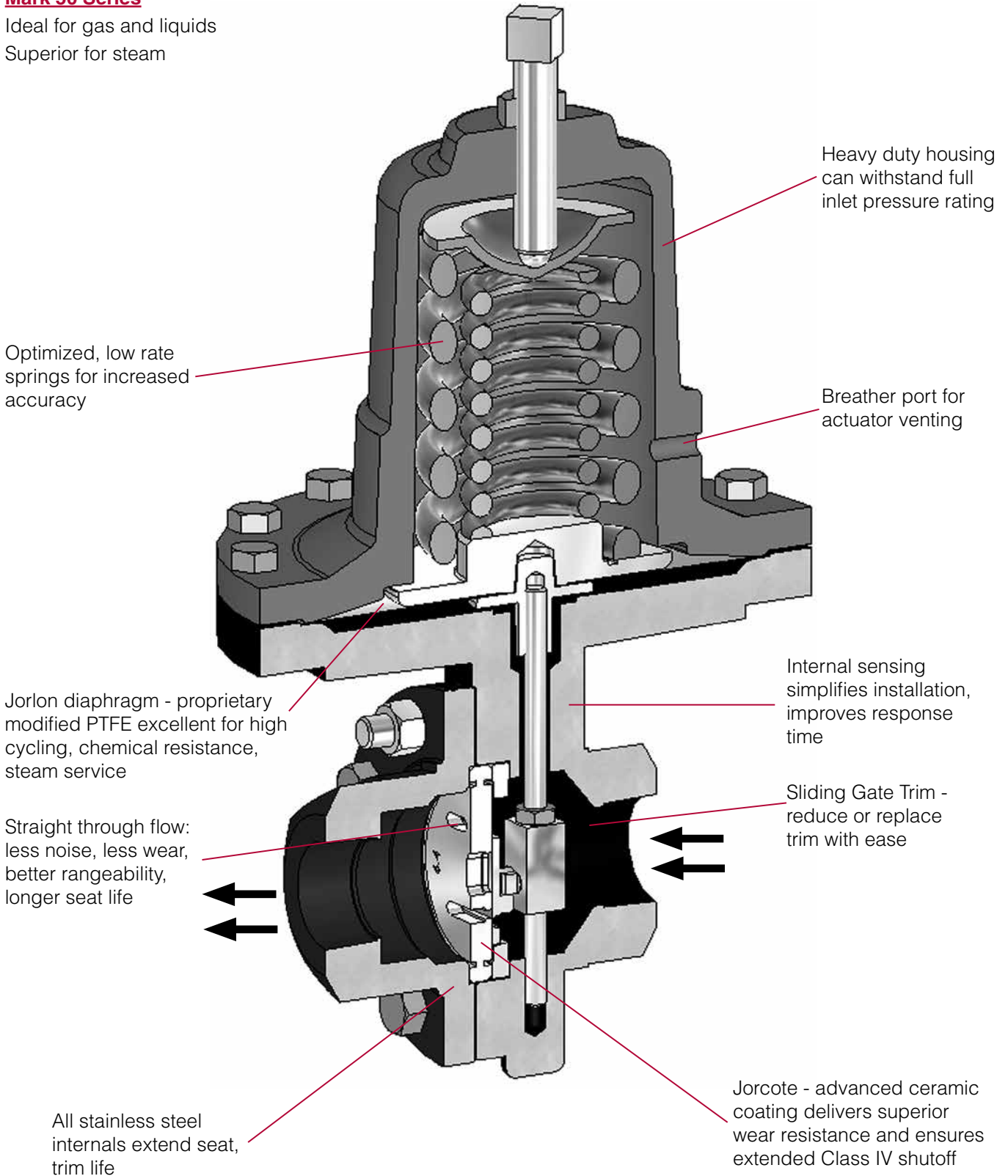

MARK 50 SELF-OPERATING BACK PRESSURE REGULATORS

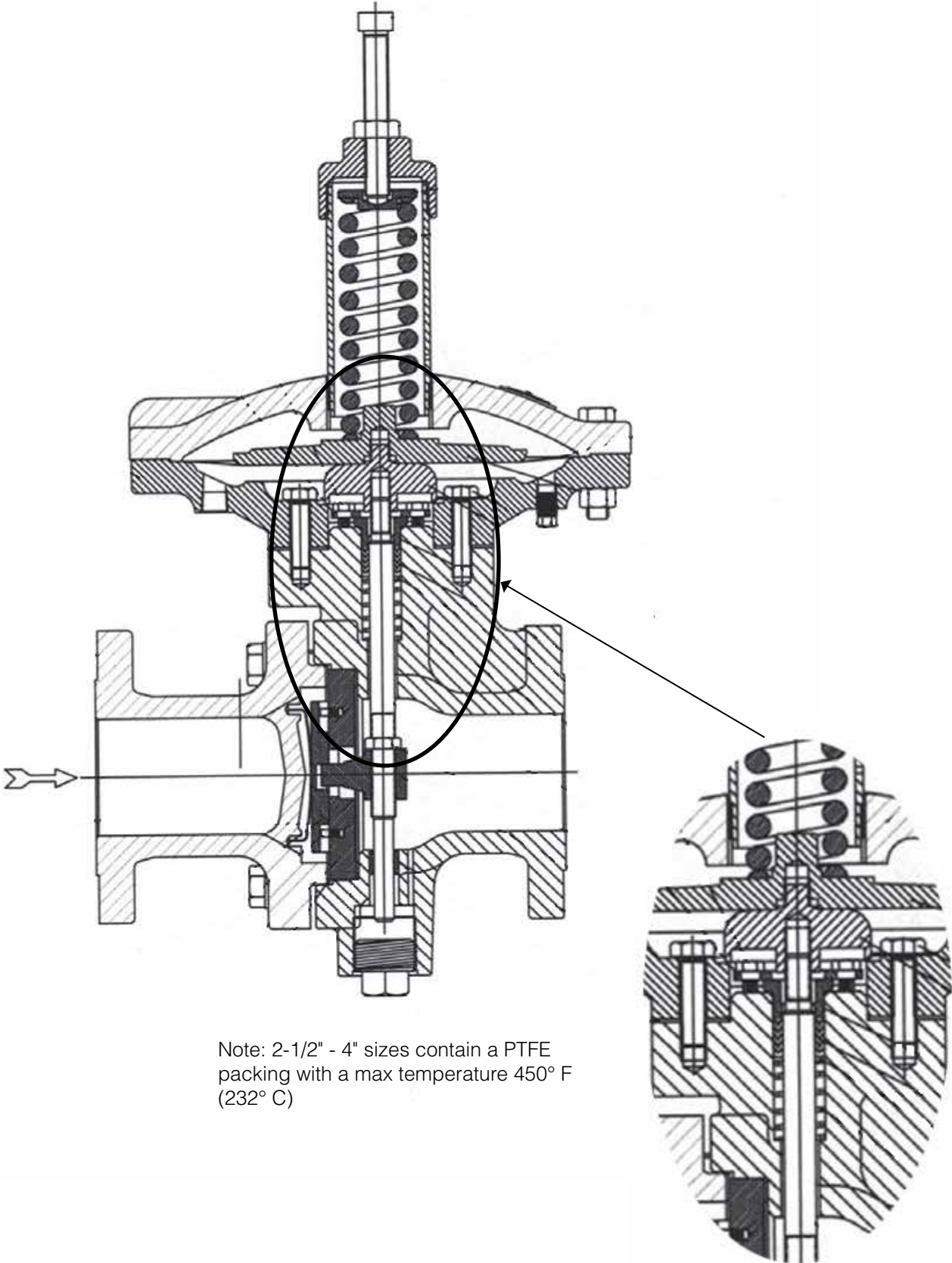

Note: 2-1/2" - 4" sizes contain a PTFE packing with a max temperature 450° F (232° C)

**SPECIFICATIONS — MK50/50QC/51/50HP**

- Sizes:** (1/4" & 3/8" sizes use 1/2" body with reducers)
- Mark 50: 1/4" through 4" (DN8 through DN100)
  - Mark 50QC: 1/4" through 2" (DN8 through DN50)
  - Mark 51: 1/4" through 3/4" (DN8 through DN20)
  - Mark 50HP: 1/4" through 4" (DN8 through DN100)

- End Connections:**
- Threaded — FNPT, BSPT, BSPP (1/2" - 2" only, DN15-DN50)
  - ANSI Flanges (150#, 300#, 600#)
  - DIN Flanges (PN10/16, PN25/40)
  - JIS Flanges (upon request)

- Spring Housing:**
- Ductile Iron — 1/4" - 2" (DN8 - DN50)
  - Ductile Iron — 2-1/2" - 4" (DN65 - DN100)

- Body Materials:**
- Ductile Iron
  - Bronze (1/2" - 2", DN15-DN50)
  - Cast Iron (2-1/2" - 4", DN65-DN100)
  - Carbon Steel (A216 WCB)
  - Stainless Steel (A351/CF8M)

- Trim Materials:**
- 303SST — Standard on Ductile Iron, Bronze, Carbon Steel valves
  - 316SST — Standard on Stainless Steel valves
  - Monel, Hastelloy and other Alloys available

**Pressure Control Ranges:** Select a range to match your setpoint. For optimal performance, your setpoint should fall in the upper portion of the selected range.

| Model     | Size (DN)                     | Spring Ranges |               |
|-----------|-------------------------------|---------------|---------------|
|           |                               | PSI           | BAR           |
| 50 & 50QC | 1/4" - 3/4"<br>(DN8 - DN20)   | 2 - 20        | 0,14 - 1,38   |
|           |                               | 10 - 30       | 0,69 - 2,07   |
|           |                               | 20 - 45       | 1,38 - 3,10   |
|           |                               | 30 - 135      | 2,07 - 9,31   |
|           |                               | 80 - 185      | 5,52 - 12,76  |
|           | 1" - 2"<br>(DN25 - DN50)      | 1/2 - 4       | 0,03 - 0,28   |
|           |                               | 2 - 6         | 0,14 - 0,41   |
|           |                               | 4 - 13        | 0,28 - 0,90   |
|           |                               | 8 - 20        | 0,55 - 1,38   |
|           |                               | 15 - 80       | 1,03 - 5,52   |
|           |                               | 45 - 150      | 3,10 - 10,34  |
|           | 2-1/2" - 4"<br>(DN65 - DN100) | 4 - 15        | 0,28 - 1,03   |
| 7 - 24    |                               | 0,48 - 1,65   |               |
| 16 - 30   |                               | 1,10 - 2,07   |               |
| 50HP      | 1/2" - 2"<br>(DN15 - DN40)    | 75 - 190      | 5,17 - 13,10  |
|           |                               | 100 - 320     | 6,89 - 22,06  |
|           |                               | 150 - 450     | 10,34 - 31,02 |
|           | 2-1/2" - 4"<br>(DN65 - DN100) | 25 - 50       | 1,72 - 3,45   |
|           |                               | 40 - 80       | 2,76 - 5,52   |
| 51        | 1/4" - 3/4"<br>(DN8 - DN20)   | 1/2 - 5       | 0,03 - 0,34   |
|           |                               | 2 - 10        | 0,14 - 0,69   |
|           |                               | 2 - 20        | 0,14 - 1,38   |
|           |                               | 10 - 30       | 0,69 - 2,07   |
|           |                               | 20 - 50       | 1,38 - 3,45   |
|           |                               | 20 - 70       | 1,38 - 4,83   |
|           |                               | 40 - 105      | 2,76 - 7,24   |
|           |                               | 25 - 150      | 1,72 - 10,34  |
|           |                               | 30 - 170      | 2,07 - 11,72  |

- Seat Materials:**
- Jorcote on SST — Standard
  - Other materials available — Consult factory

- Diaphragm Materials:**
- Jorlon - Standard
  - Stainless Steel - Standard
  - Buna-N - Standard
  - Viton - Optional

**Service:** Steam, water, oil, gas, air and chemicals

**Shutoff:** ANSI Class IV

- Options:**
- **Double Bolting:** improves the pressure rating of the valve and ensures a tight seal between the spring housing and the body for services with high inlet pressures.
  - **High Pressure Spring Housing:** the HP option is an elongated spring housing that features a large spring for high pressure setpoints (up to 450 psi/31bar).
  - **Handwheel:** the H option is a handwheel that is mounted on the adjusting screw to allow for easy setpoint changes.
  - **Exotic Alloys:** where service conditions dictate the use of specialty materials, the Mark 50 Series can be produced with bodies, trim and seats in Monel, Alloy 20, Hastelloy B, Hastelloy C, Titanium and others.
  - **GP Option:** grain processing modification for starch cookers and other viscous services.
  - **Cryogenic Service:** CR option is a special spring housing for use if valve is in cryogenic conditions.

**Cv Values & Maximum Differential Pressures**

| Cv (Kv)     | Size (DN)                    | Seat Material | Max. ΔP PSI (bar) |
|-------------|------------------------------|---------------|-------------------|
| 0.84 (0,74) | 1/4" (DN8)                   | Jorcote       | 500 (34)          |
| 1.6 (1,4)   | 3/8" (DN12)                  | Jorcote       | 500 (34)          |
| 2.5 (2,2)   | 1/2" & 3/4"<br>(DN15 & DN20) | Jorcote       | 450 (31)          |
| 4.4 (3,8)   |                              |               |                   |
| 6.4 (5,5)   | 1" & 1-1/4"<br>(DN25 & DN32) | Jorcote       | 450 (31)          |
| 9.5 (8,2)   |                              |               |                   |
| 15 (12,9)   | 1-1/2" (DN40)                | Jorcote       | 450 (31)          |
| 25 (21,5)   | 2" (DN50)                    | Jorcote       | 450 (31)          |
| 30 (25,8)   |                              |               |                   |
| 55 (47,3)   | 2-1/2" (DN65)                | Jorcote       | 150 (10)          |
| 115 (99)    | 3" (DN75)                    | Jorcote       | 150 (10)          |
| 200 (172)   | 4" (DN100)                   | Jorcote       | 150 (10)          |

**Low Flow Cv's:** reduced Cv's (Kv's) are available. Cv (Kv) ratings of smaller valves can be supplied in larger-sized valves.

|               |               |               |                                   |             |
|---------------|---------------|---------------|-----------------------------------|-------------|
| 0.42 (0,36)   | 0.21 (0,18)   | 0.08 (0,07)   | 0.04 (0,03)                       | 0.02 (0,02) |
| 0.008 (0,007) | 0.004 (0,003) | 0.002 (0,002) | 0.0008 (0,0007)<br>(N/A in 316SS) |             |

**MARK 50 SELF-OPERATING BACK PRESSURE REGULATORS**

**MAXIMUM WORKING PRESSURE, PSI**

**MAXIMUM WORKING PRESSURE, BAR**

| Temp °F | 1/4" - 2" |           |           |          |           |           |
|---------|-----------|-----------|-----------|----------|-----------|-----------|
|         | DI Body   |           |           | BRZ Body |           |           |
|         | 150#      | 300#      | TE        | 150#     | 300#      | TE        |
| -20-100 | 250       | 300 (600) | 300 (600) | 225      | 300 (500) | 300 (500) |
| 200     | 235       | 300 (600) | 300 (600) | 215      | 300 (475) | 300 (475) |
| 300     | 215       | 300 (565) | 300 (600) | 195      | 300 (425) | 300 (425) |
| 400     | 200       | 300 (525) | 300 (600) | 170      | 300 (375) | 300 (375) |
| 500     | 170       | 300 (495) | 300 (600) | 150      | 300 (325) | 300 (325) |
| 600     | 140       | 300 (465) | 300 (600) | —        | —         | —         |
| 650     | 125       | 300 (450) | 300 (600) | —        | —         | —         |

| Temp °C   | DN8 - DN50 |         |         |          |         |         |
|-----------|------------|---------|---------|----------|---------|---------|
|           | DI Body    |         |         | BRZ Body |         |         |
|           | 150#       | 300#    | TE      | 150#     | 300#    | TE      |
| -29 to 38 | 17         | 21 (41) | 21 (41) | 16       | 21 (34) | 21 (34) |
| 93        | 16         | 21 (41) | 21 (41) | 15       | 21 (33) | 21 (33) |
| 149       | 15         | 21 (39) | 21 (41) | 13       | 21 (29) | 21 (29) |
| 204       | 14         | 21 (36) | 21 (41) | 12       | 21 (26) | 21 (26) |
| 260       | 12         | 21 (34) | 21 (41) | 10       | 21 (22) | 21 (22) |
| 316       | 10         | 21 (32) | 21 (41) | —        | —       | —       |
| 343       | 9          | 21 (31) | 21 (41) | —        | —       | —       |

| Temp °F | 1/4" - 2" |           |           |         |           |           |
|---------|-----------|-----------|-----------|---------|-----------|-----------|
|         | CS Body   |           |           | SS Body |           |           |
|         | 150#      | 300#      | TE        | 150#    | 300#      | TE        |
| -20-100 | 285       | 300 (740) | 300 (950) | 275     | 300 (720) | 300 (950) |
| 200     | 260       | 300 (675) | 300 (950) | 240     | 300 (620) | 300 (950) |
| 300     | 230       | 300 (655) | 300 (950) | 215     | 300 (560) | 300 (950) |
| 400     | 200       | 300 (635) | 300 (950) | 195     | 300 (515) | 300 (950) |
| 500     | 170       | 300 (600) | 300 (950) | 170     | 300 (480) | 300 (950) |
| 600     | 140       | 300 (550) | 300 (950) | 140     | 300 (450) | 300 (950) |
| 650     | 125       | 300 (535) | 300 (950) | 125     | 300 (445) | 300 (950) |

| Temp °C   | DN8 - DN50 |         |         |         |         |         |
|-----------|------------|---------|---------|---------|---------|---------|
|           | CS Body    |         |         | SS Body |         |         |
|           | 150#       | 300#    | TE      | 150#    | 300#    | TE      |
| -29 to 38 | 20         | 21 (51) | 21 (66) | 19      | 21 (49) | 21 (66) |
| 93        | 18         | 21 (47) | 21 (66) | 17      | 21 (43) | 21 (66) |
| 149       | 16         | 21 (45) | 21 (66) | 15      | 21 (39) | 21 (66) |
| 204       | 14         | 21 (44) | 21 (66) | 13      | 21 (36) | 21 (66) |
| 260       | 12         | 21 (41) | 21 (66) | 12      | 21 (33) | 21 (66) |
| 316       | 10         | 21 (38) | 21 (66) | 10      | 21 (31) | 21 (62) |
| 343       | 9          | 21 (37) | 21 (66) | 9       | 21 (31) | 21 (61) |

| Temp °F    | 2-1/2" - 4" |      |         |      |         |      |
|------------|-------------|------|---------|------|---------|------|
|            | DI Body     |      | CS Body |      | SS Body |      |
|            | 150#        | 300# | 150#    | 300# | 150#    | 300# |
| -20 to 100 | 250         | 500  | 285     | 500  | 275     | 500  |
| 200        | 235         | 500  | 260     | 500  | 240     | 500  |
| 300        | 215         | 500  | 230     | 500  | 215     | 500  |
| 400        | 200         | 500  | 200     | 500  | 195     | 500  |
| 450        | 170         | 495  | 170     | 500  | 170     | 500  |

| Temp °C   | DN65 - DN100 |      |         |      |         |      |
|-----------|--------------|------|---------|------|---------|------|
|           | DI Body      |      | CS Body |      | SS Body |      |
|           | 150#         | 300# | 150#    | 300# | 150#    | 300# |
| -29 to 38 | 17           | 34   | 20      | 34   | 19      | 34   |
| 93        | 16           | 34   | 18      | 34   | 17      | 34   |
| 149       | 15           | 34   | 16      | 34   | 15      | 34   |
| 204       | 4            | 34   | 14      | 34   | 13      | 34   |
| 232       | 12           | 34   | 12      | 34   | 12      | 34   |

| Temp °F | 50 HP Series (1/2" - 2") |                    |
|---------|--------------------------|--------------------|
|         | CS Body                  | SS Body            |
|         | 600# Flange or NPT       | 600# Flange or NPT |
| 100     | 1480                     | 1440               |
| 200     | 1355                     | 1240               |
| 300     | 1315                     | 1120               |
| 400     | 1270                     | 1030               |
| 500     | 1208                     | 955                |
| 600     | 1095                     | 905                |
| 650     | 1075                     | 890                |

| Temp °C | 50 HP Series (DN15 - DN50) |                    |
|---------|----------------------------|--------------------|
|         | CS Body                    | SS Body            |
|         | 600# Flange or NPT         | 600# Flange or NPT |
| 38      | 102                        | 99                 |
| 93      | 93                         | 85                 |
| 149     | 91                         | 77                 |
| 204     | 88                         | 71                 |
| 260     | 83                         | 66                 |
| 316     | 75                         | 62                 |
| 343     | 74                         | 61                 |

Notes:

1. Double bolting option is required to reach pressures indicated in parentheses ( ).
2. If weld flanges are supplied, use ratings in "TE" column or flange rating, whichever is less (i.e. ANSI 600/900 flanges or PN64/100 flanges).

**DIMENSIONS — MK50/MK50QC**

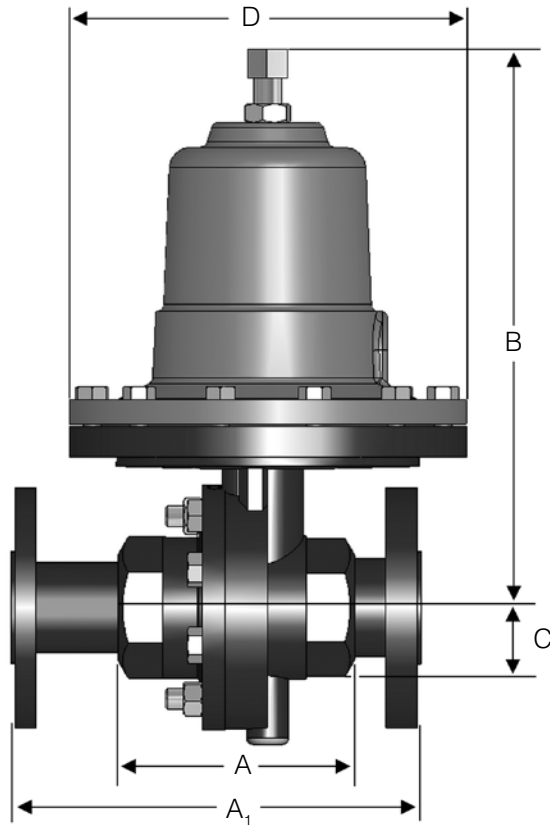

• Mark 50 / Mark 50QC\*: Threaded & FSW Ends

| Size        | Mat'l  | Dimensions (inches) |       |       |      |      | Weight (lbs.) |
|-------------|--------|---------------------|-------|-------|------|------|---------------|
|             |        | A                   | B     | B~QC  | C    | D    |               |
| 1/2" & 3/4" | DI/BRZ | 3.62                | 8.50  | 10.25 | 1.69 | 5.12 | 10            |
|             | CS/SS  | 3.62                | 8.50  | 10.25 | 1.69 | 5.12 | 12            |
| 1"          | DI/BRZ | 4.12                | 10.00 | 11.37 | 2.62 | 7.09 | 21            |
|             | CS/SS  | 4.18                | 10.75 | 12.00 | 2.63 | 7.09 | 25            |
| 1-1/4"      | DI/BRZ | 4.12                | 10.00 | 11.37 | 2.62 | 7.09 | 21            |
| 1-1/2"      | DI/BRZ | 4.50                | 10.25 | 11.37 | 2.31 | 7.09 | 23            |
|             | CS/SS  | 4.81                | 11.00 | 12.25 | 2.25 | 7.09 | 31            |
| 2"          | DI/BRZ | 4.50                | 10.25 | 11.37 | 2.75 | 7.09 | 26            |
|             | CS/SS  | 5.50                | 11.00 | 12.25 | 2.75 | 7.09 | 35            |

\* For MK50QC, use column B~QC.

• Mark 50 / Mark 50QC\*: Threaded & FSW Ends, Metric

| Size      | Mat'l  | Dimensions |        |        |       |        | Wgt. (kg) |
|-----------|--------|------------|--------|--------|-------|--------|-----------|
|           |        | A          | B      | B~QC   | C     | D      |           |
| DN15 & 20 | DI/BRZ | 91,95      | 215,90 | 260,35 | 42,93 | 130,05 | 4,5       |
|           | CS/SS  | 91,95      | 215,90 | 260,35 | 42,93 | 130,05 | 5,4       |
| DN25      | DI/BRZ | 104,65     | 254,00 | 288,80 | 66,55 | 180,09 | 9,5       |
|           | CS/SS  | 106,17     | 273,05 | 304,80 | 66,55 | 180,09 | 11,3      |
| DN32      | DI/BRZ | 104,65     | 254,00 | 288,80 | 66,55 | 180,09 | 9,5       |
| DN40      | DI/BRZ | 114,30     | 260,35 | 288,80 | 58,67 | 180,09 | 10,4      |
|           | CS/SS  | 122,17     | 279,40 | 311,15 | 57,15 | 180,09 | 14,1      |
| DN50      | DI/BRZ | 114,30     | 260,35 | 288,80 | 69,85 | 180,09 | 11,8      |
|           | CS/SS  | 139,70     | 279,40 | 311,15 | 69,85 | 180,09 | 15,9      |

\* For MK50QC, use column B~QC.

# MARK 50 SELF-OPERATING BACK PRESSURE REGULATORS

## DIMENSIONS — MK50

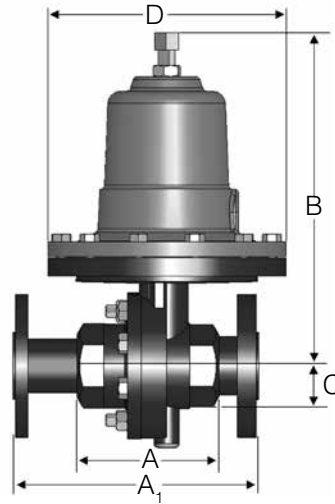

- Mark 50: Integral Flanges - ANSI, CS & SS Bodies

| Size   | ANSI Flange | Dimensions (inches) |                   |        |       |      |      | Weight (lbs.) |       |
|--------|-------------|---------------------|-------------------|--------|-------|------|------|---------------|-------|
|        |             | A1                  |                   | B      |       | C    | D    | DI/BRZ        | CS/SS |
|        |             | DI/BRZ              | CS/SS             | DI/BRZ | CS/SS | All  | All  |               |       |
| 1/2"   | 150#        | 7.25                | 7.25              | 8.50   | 8.50  | 1.69 | 5.12 | 13            | 15    |
|        | 300#        | 7.50                | 7.50              | 8.50   | 8.50  | 1.69 | 5.12 | 14            | 16    |
| 3/4"   | 150#        | 7.25                | 7.25              | 8.50   | 8.50  | 1.69 | 5.12 | 14            | 16    |
|        | 300#        | 7.62                | 7.62              | 8.50   | 8.50  | 1.69 | 5.12 | 16            | 17    |
| 1"     | 150#        | 7.25 <sup>1</sup>   | 7.25 <sup>2</sup> | 10.0   | 10.75 | 2.62 | 7.09 | 26            | 34    |
|        | 300#        | 8.75 <sup>1</sup>   | 7.75 <sup>2</sup> | 10.0   | 10.75 | 2.62 | 7.09 | 28            | 37    |
| 1 1/4" | 150#        | 7.87                | —                 | 10.0   | —     | 2.62 | 7.09 | 28            | —     |
|        | 300#        | 8.37                | —                 | 10.0   | —     | 2.62 | 7.09 | 31            | —     |
| 1 1/2" | 150#        | 8.75 <sup>1</sup>   | 8.75 <sup>2</sup> | 10.25  | 11.22 | 2.31 | 7.09 | 42            | 46    |
|        | 300#        | 10.25 <sup>1</sup>  | 9.25 <sup>2</sup> | 10.25  | 11.22 | 2.31 | 7.09 | 45            | 52    |
| 2"     | 150#        | 10.0                | 10.0              | 10.25  | 11.42 | 2.75 | 7.09 | 46            | 50    |
|        | 300#        | 10.5                | 10.5              | 10.25  | 11.42 | 2.75 | 7.09 | 49            | 55    |

Note: Dimensions for 2-1/2" to 4" sizes apply to DI bodies also.

<sup>1</sup> Not ANSI Standard, <sup>2</sup> IFE only

- Mark 50: Integral Flanges - Metric

| Size (DN) | Flange (PN) | Dimensions         |                    |        |       |      |     | Weight (kg) |       |
|-----------|-------------|--------------------|--------------------|--------|-------|------|-----|-------------|-------|
|           |             | A1                 |                    | B      |       | C    | D   | DI/BRZ      | CS/SS |
|           |             | DI/BRZ             | CS/SS              | DI/BRZ | CS/SS | All  | All |             |       |
| 15        | 10/16       | 184,2              | 184,2              | 215,9  | 215,9 | 42,9 | 130 | 5,9         | 5,9   |
|           | 25/40       | 190,5              | 190,5              | 215,9  | 215,9 | 42,9 | 130 | 6,4         | 6,4   |
| 20        | 10/16       | 184,5              | 184,2              | 215,9  | 215,9 | 42,9 | 130 | 6,4         | 6,4   |
|           | 25/40       | 193,5              | 193,5              | 215,9  | 215,9 | 42,9 | 130 | 7,3         | 7,7   |
| 25        | 10/16       | 184,2 <sup>1</sup> | 184,2 <sup>2</sup> | 254,0  | 273,1 | 66,5 | 180 | 11,8        | 15,4  |
|           | 25/40       | 223,1 <sup>1</sup> | 196,9              | 254,0  | 273,1 | 66,5 | 180 | 12,7        | 16,8  |
| 32        | 10/16       | 199,9              | —                  | 254,0  | —     | 66,5 | 180 | 12,7        | —     |
|           | 25/40       | 212,6              | —                  | 254,0  | —     | 66,5 | 180 | 14,1        | —     |
| 40        | 10/16       | 222,3 <sup>1</sup> | 222,3 <sup>2</sup> | 260,4  | 285,0 | 58,7 | 180 | 19,1        | 20,9  |
|           | 25/40       | 260,3 <sup>1</sup> | 235,0 <sup>2</sup> | 260,4  | 285,0 | 58,7 | 180 | 20,4        | 23,6  |
| 50        | 10/16       | 254,0              | 254,0              | 260,4  | 290,1 | 69,9 | 180 | 20,9        | 22,7  |
|           | 25/40       | 266,7              | 266,7              | 260,4  | 290,1 | 69,9 | 180 | 22,2        | 24,9  |

Note: Dimensions for DN65 to DN80 sizes apply to DI bodies also.

<sup>1</sup> Not ANSI Standard, <sup>2</sup> IFE only

- Mark 50: Companion Flanges - ANSI, Ductile & Bronze Bodies

| Size   | Flange | Dimensions (inches) |       |      |      | Weight (lbs.) |
|--------|--------|---------------------|-------|------|------|---------------|
|        |        | A                   | B     | C    | D    |               |
| 1/2"   | 150#   | 7.25                | 8.50  | 1.75 | 5.12 | 13            |
|        | 300#   | 7.50                | 8.50  | 1.87 | 5.12 | 14            |
| 3/4"   | 150#   | 7.25                | 8.50  | 1.93 | 5.12 | 14            |
|        | 300#   | 7.62                | 8.50  | 2.31 | 5.12 | 16            |
| 1"     | 150#   | 7.25                | 10.00 | 2.12 | 7.09 | 26            |
|        | 300#   | 8.75                | 10.00 | 2.43 | 7.09 | 28            |
| 1-1/4" | 150#   | 7.87                | 10.00 | 2.31 | 7.09 | 28            |
|        | 300#   | 8.37                | 10.00 | 2.62 | 7.09 | 31            |
| 1-1/2" | 150#   | 8.75                | 10.25 | 2.50 | 7.09 | 42            |
|        | 300#   | 10.25               | 10.25 | 3.06 | 7.09 | 45            |
| 2"     | 150#   | 10.00               | 10.25 | 3.00 | 7.09 | 46            |
|        | 300#   | 10.50               | 10.25 | 3.25 | 7.09 | 49            |

- Mark 50: Companion Flanges - ANSI, Ductile & Bronze Bodies - Metric

| Size (DN) | Flange (PN) | Dimensions |       |      |     | Weight (kg) |
|-----------|-------------|------------|-------|------|-----|-------------|
|           |             | A          | B     | C    | D   |             |
| 15        | 10/16       | 184,2      | 215,9 | 44,5 | 130 | 5,9         |
|           | 25/40       | 190,5      | 215,9 | 47,5 | 130 | 6,4         |
| 20        | 10/16       | 184,4      | 215,9 | 49,0 | 130 | 6,4         |
|           | 25/40       | 193,5      | 215,9 | 58,7 | 130 | 7,3         |
| 25        | 10/16       | 184,2      | 254,0 | 53,8 | 180 | 11,8        |
|           | 25/40       | 222,3      | 254,0 | 61,7 | 180 | 12,7        |
| 32        | 10/16       | 199,9      | 254,0 | 58,7 | 180 | 12,7        |
|           | 25/40       | 212,6      | 254,0 | 66,5 | 180 | 14,1        |
| 40        | 10/16       | 222,3      | 260,4 | 63,5 | 180 | 19,1        |
|           | 25/40       | 260,3      | 260,4 | 77,7 | 180 | 20,4        |
| 50        | 10/16       | 254,0      | 260,4 | 76,2 | 180 | 20,9        |
|           | 25/40       | 266,7      | 260,4 | 82,6 | 180 | 22,2        |

# MARK 50 SELF-OPERATING BACK PRESSURE REGULATORS

## DIMENSIONS — MK50

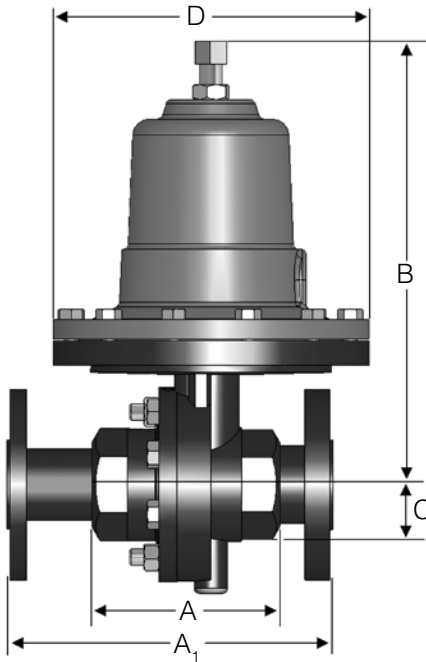

• Mark 50: Flanged Ends, ANSI

| Size               | ANSI Flange | Dimensions (inches) |                   |        |       |               |      | Weight (lbs.) |       |
|--------------------|-------------|---------------------|-------------------|--------|-------|---------------|------|---------------|-------|
|                    |             | A1                  |                   | B      |       | C             | D    | DI/BRZ        | CS/SS |
|                    |             | DI/BRZ              | CS/SS             | DI/BRZ | CS/SS | All           | All  |               |       |
| 1/2"               | 150#        | 7.25                | 7.25              | 8.50   | 8.50  | 1.69          | 5.12 | 13            | 15    |
|                    | 300#        | 7.50                | 7.50              | 8.50   | 8.50  | 1.69          | 5.12 | 14            | 16    |
| 3/4"               | 150#        | 7.25                | 7.25              | 8.50   | 8.50  | 1.69          | 5.12 | 14            | 16    |
|                    | 300#        | 7.62                | 7.62              | 8.50   | 8.50  | 1.69          | 5.12 | 16            | 17    |
| 1"                 | 150#        | 7.25                | 7.25              | 10.0   | 10.75 | 2.62          | 7.09 | 26            | 34    |
|                    | 300#        | 8.75 <sup>1</sup>   | 7.75 <sup>2</sup> | 10.00  | 10.75 | 2.62          | 7.09 | 28            | 37    |
| 1 1/4"             | 150#        | 7.87                | —                 | 10.00  | —     | 2.62          | 7.09 | 31            | —     |
|                    | 300#        | 8.37                | —                 | 10.00  | —     | 2.62          | 7.09 | 31            | —     |
| 1 1/2"             | 150#        | 8.75                | 8.75              | 10.25  | 11.22 | 2.31          | 7.09 | 42            | 46    |
|                    | 300#        | 10.25 <sup>1</sup>  | 9.25 <sup>2</sup> | 10.25  | 11.22 | 2.31          | 7.09 | 45            | 52    |
| 2"                 | 150#        | 10.00               | 10.00             | 10.25  | 11.42 | 2.75          | 7.09 | 46            | 50    |
|                    | 300#        | 10.50               | 10.50             | 10.25  | 11.42 | 2.75          | 7.09 | 49            | 55    |
| Flanged Ends CS/SS |             |                     |                   |        |       |               |      |               |       |
| Larger Sizes       |             | A                   | B                 | C      | D     | Weight (lbs.) |      |               |       |
| 2-1/2"             | 125-150#    | 10.88               | 18.75             | 6.95   | 12.75 | 165           |      |               |       |
|                    | 250-300#    | 11.50               | 18.75             | 6.95   | 12.75 | 165           |      |               |       |
| 3"                 | 125-150#    | 11.75               | 18.75             | 6.95   | 12.75 | 185           |      |               |       |
|                    | 250-300#    | 12.50               | 18.75             | 6.95   | 12.75 | 185           |      |               |       |
| 4"                 | 125-150#    | 13.88               | 19.95             | 8.00   | 12.75 | 215           |      |               |       |
|                    | 250-300#    | 14.50               | 19.95             | 8.00   | 12.75 | 215           |      |               |       |

1. Not ANSI Standard.
2. IFE only.

• Mark 50: Flanged Ends, Metric

| Size DN            | Flange PN | Dimensions (mm) |       |        |       |             |     | Weight (kg) |       |
|--------------------|-----------|-----------------|-------|--------|-------|-------------|-----|-------------|-------|
|                    |           | A1              |       | B      |       | C           | D   | DI/BRZ      | CS/SS |
|                    |           | DI/BRZ          | CS/SS | DI/BRZ | CS/SS | All         | All |             |       |
| 15                 | 10/16     | 184             | 130   | 216    | 240   | 43          | 130 | 5,9         | 6,8   |
|                    | 25/40     | 184             | 130   | 216    | 240   | 43          | 130 | 6,4         | 7,3   |
| 20                 | 10/16     | 184             | 150   | 216    | 240   | 43          | 130 | 6,4         | 7,3   |
|                    | 25/40     | 184             | 150   | 216    | 240   | 43          | 130 | 7,3         | 7,7   |
| 25                 | 10/16     | 184             | 160   | 273    | 262   | 67          | 180 | 11,8        | 15,4  |
|                    | 25/40     | 184             | 160   | 273    | 262   | 67          | 180 | 12,7        | 16,8  |
| 32                 | 10/16     | 200             | —     | 273    | —     | 67          | 180 | 12,7        | —     |
|                    | 25/40     | 200             | —     | 273    | —     | 67          | 180 | 4,1         | —     |
| 40                 | 10/16     | 222             | 200   | 279    | 285   | 59          | 180 | 19,1        | 20,9  |
|                    | 25/40     | 222             | 200   | 279    | 285   | 59          | 180 | 20,4        | 23,6  |
| 50                 | 10/16     | 254             | 230   | 279    | 290   | 70          | 180 | 20,9        | 22,7  |
|                    | 25/40     | 254             | 230   | 279    | 290   | 70          | 180 | 22,2        | 24,9  |
| Flanged Ends CS/SS |           |                 |       |        |       |             |     |             |       |
| Larger Sizes       |           | A               | B     | C      | D     | Weight (kg) |     |             |       |
| 65                 | 10/16     | 283             | 476   | 177    | 324   | 75          |     |             |       |
|                    | 25/40     | 283             | 476   | 177    | 324   | 75          |     |             |       |
| 80                 | 10/16     | 312             | 476   | 177    | 324   | 84          |     |             |       |
|                    | 25/40     | 312             | 476   | 177    | 324   | 84          |     |             |       |
| 100                | 10/16     | 350             | 507   | 203    | 324   | 98          |     |             |       |
|                    | 25/40     | 350             | 507   | 203    | 324   | 98          |     |             |       |

1. Smaller sizes A1 not IFE and not per DIN 3202.
2. Larger sizes A not per DIN 3202.



# MARK 50HP SELF-OPERATING BACK PRESSURE REGULATORS

## DIMENSIONS — MK50HP

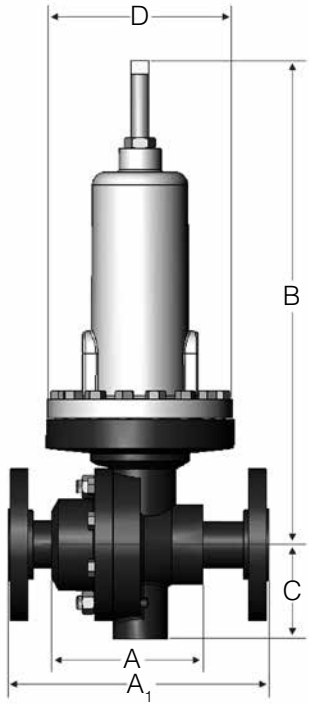

### • Mark 50HP: Flanged Ends

| Size   | Flange | Dimensions (inches) |       |       |      |      | Weight (lbs.) |
|--------|--------|---------------------|-------|-------|------|------|---------------|
|        |        | A1                  |       | B†    | C    | D    |               |
|        |        | DI/BRZ              | CS/SS | All   | All  | All  |               |
| 1/2"   | 150#   | 7.25                | 7.25  | 12.75 | 1.69 | 5.20 | 21            |
|        | 300#   | 7.50                | 7.50  | 12.75 | 1.69 | 5.20 |               |
|        | 600#‡  | 8.00                | 8.00  | 12.25 | 1.69 | 5.20 |               |
| 3/4"   | 150#   | 7.25                | 7.25  | 12.75 | 1.69 | 5.20 | 22            |
|        | 300#   | 7.62                | 7.62  | 12.75 | 1.69 | 5.20 |               |
|        | 600#‡  | 8.12                | 8.12  | 12.25 | 1.69 | 5.20 |               |
| 1"     | 150#   | 7.25                | 7.25  | 13.25 | 2.62 | 5.20 | 37            |
|        | 300#   | 7.75                | 7.75  | 13.25 | 2.62 | 5.20 |               |
|        | 600#‡  | 8.25                | 8.25  | 12.75 | 2.62 | 5.20 |               |
| 1-1/4" | 150#   | 7.87                | —     | 12.75 | 2.62 | 5.20 | 37            |
|        | 300#   | 8.37                | —     | 12.75 | 2.62 | 5.20 |               |
| 1-1/2" | 150#   | 8.75                | 8.75  | 13.75 | 2.31 | 5.20 | 45            |
|        | 300#   | 9.25                | 9.25  | 13.75 | 2.31 | 5.20 |               |
|        | 600#‡  | 9.87                | 9.87  | 13.25 | 2.31 | 5.20 |               |
| 2"     | 150#   | 10.00               | 10.00 | 14.00 | 2.75 | 5.20 | 49            |
|        | 300#   | 10.50               | 10.50 | 14.00 | 2.75 | 5.20 |               |
|        | 600#‡  | 11.25               | 11.25 | 13.50 | 2.75 | 5.20 |               |

† For IFE, add 1" (25,4mm) to all "B" dimensions.

‡ 600# are not IFE

### • Mark 50HP: Threaded & FSW Ends

| Size        | Mat'l  | Dimensions (inches) |       |      |      | Weight (lbs.) |
|-------------|--------|---------------------|-------|------|------|---------------|
|             |        | A                   | B     | C    | D    |               |
| 1/2" & 3/4" | DI/BRZ | 3.62                | 12.75 | 1.75 | 5.12 | 15            |
|             | CS/SS  | 3.62                | 12.75 | 1.75 | 5.12 | 17            |
| 1"          | DI/BRZ | 4.12                | 13.00 | 2.12 | 5.20 | 21            |
|             | CS/SS  | 4.18                | 13.25 | 2.12 | 5.20 | 25            |
| 1-1/4"      | DI/BRZ | 4.12                | 13.00 | 2.12 | 5.20 | 21            |
| 1-1/2"      | DI/BRZ | 4.50                | 13.25 | 2.31 | 5.20 | 23            |
|             | CS/SS  | 4.81                | 13.75 | 2.50 | 5.20 | 31            |
| 2"          | DI/BRZ | 4.50                | 13.25 | 2.50 | 5.20 | 26            |
|             | CS/SS  | 5.50                | 14.00 | 2.50 | 5.20 | 35            |

### • Mark 50HP: Threaded & FSW Ends, Metric

| Size (DN) | Mat'l  | Dimensions |     |      |       | Weight (kg) |
|-----------|--------|------------|-----|------|-------|-------------|
|           |        | A          | B   | C    | D     |             |
| 15 & 20   | DI/BRZ | 92,0       | 324 | 44,5 | 130,0 | 6,8         |
|           | CS/SS  | 92,0       | 324 | 44,5 | 130,0 | 7,7         |
| 25        | DI/BRZ | 104,7      | 330 | 53,9 | 132,1 | 9,5         |
|           | CS/SS  | 106,2      | 337 | 53,9 | 132,1 | 11,3        |
| 32        | DI/BRZ | 104,7      | 330 | 53,9 | 132,1 | 9,5         |
| 40        | DI/BRZ | 114,3      | 337 | 58,7 | 132,1 | 10,4        |
|           | CS/SS  | 122,2      | 349 | 63,5 | 132,1 | 14,1        |
| 50        | DI/BRZ | 114,3      | 337 | 63,5 | 132,1 | 11,8        |
|           | CS/SS  | 139,7      | 356 | 63,5 | 132,1 | 15,9        |

### • Mark 50HP: Flanged Ends, Metric<sup>3</sup>

| Size (DN) | Flange PN | Dimensions (mm)     |       |                |      |       | Weight (kg) |
|-----------|-----------|---------------------|-------|----------------|------|-------|-------------|
|           |           | A1                  |       | B <sup>2</sup> | C    | D     |             |
|           |           | DI/BRZ <sup>1</sup> | CS/SS | All            | All  | All   |             |
| 15        | 10/16     | 184,2               | 130,0 | 324            | 42,9 | 132,1 | 9,5         |
|           | 25/40     | 184,2               | 130,0 | 324            | 42,9 | 132,1 |             |
| 20        | 10/16     | 184,2               | 150,0 | 324            | 42,9 | 132,1 | 10,0        |
|           | 25/40     | 184,2               | 150,0 | 324            | 42,9 | 132,1 |             |
| 25        | 10/16     | 184,2               | 160,0 | 337            | 66,6 | 132,1 | 16,8        |
|           | 25/40     | 184,2               | 160,0 | 337            | 66,6 | 132,1 |             |
| 32        | 10/16     | 199,9               | —     | 324            | 66,6 | 132,1 | 16,8        |
|           | 25/40     | 199,9               | —     | 324            | 66,6 | 132,1 |             |
| 40        | 10/16     | 222,3               | 200,0 | 349            | 58,7 | 132,1 | 20,4        |
|           | 25/40     | 222,3               | 200,0 | 349            | 58,7 | 132,1 |             |
| 50        | 10/16     | 254,0               | 230,0 | 356            | 69,9 | 132,1 | 22,2        |
|           | 25/40     | 254,0               | 230,0 | 356            | 69,9 | 132,1 |             |

1. Not IFE & not per DIN3202

2. For IFE, add 25,4mm.

3. For DIN flanges above PN40, please consult factory.

**DIMENSIONS — MK51**

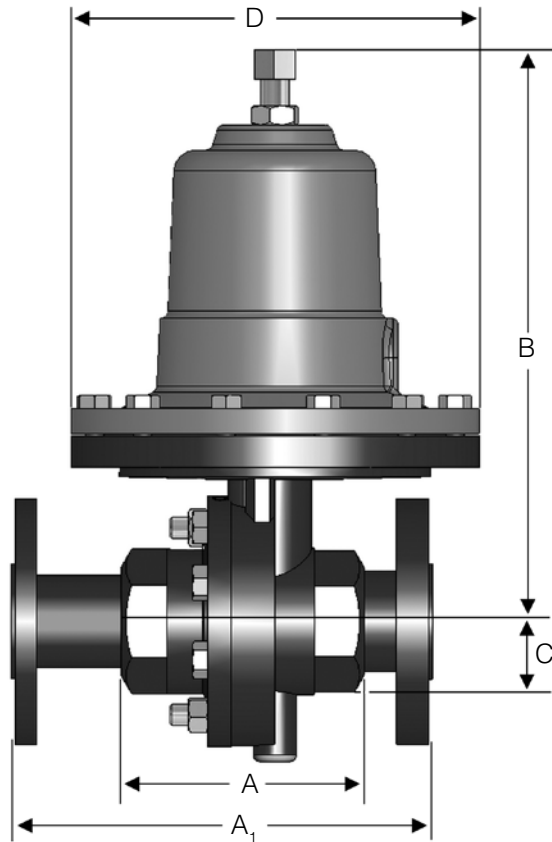

• Mark 51: Threaded & FSW Ends

| Size        | Material | Dimensions (inches) |       |      |      | Weight (lbs.) |
|-------------|----------|---------------------|-------|------|------|---------------|
|             |          | A                   | B     | C    | D    |               |
| 1/2" & 3/4" | DI/BRZ   | 3.62                | 10.25 | 2.25 | 7.12 | 12            |
|             | CS/SS    | 3.62                | 10.25 | 2.25 | 7.12 | 13            |

• Mark 51, Flanged Ends

| Size        | ANSI Flange | Dimensions (inches) |       |        |       |      |      | Weight (lbs.) |       |
|-------------|-------------|---------------------|-------|--------|-------|------|------|---------------|-------|
|             |             | A1                  |       | B      |       | C    | D    | DI/BRZ        | CS/SS |
|             |             | DI/BRZ              | CS/SS | DI/BRZ | CS/SS | All  | All  |               |       |
| 1/2" & 3/4" | 150#        | 9.62                | 9.62  | 10.25  | 10.25 | 2.25 | 7.12 | 26            | 26    |
|             | 300#        | 10.25               | 10.25 | 10.25  | 10.25 | 2.25 | 7.12 | 29            | 29    |

• Mark 51: Threaded & FSW Ends, Metric

| Size (DN) | Material | Dimensions (mm) |       |      |       | Weight (kg) |
|-----------|----------|-----------------|-------|------|-------|-------------|
|           |          | A               | B     | C    | D     |             |
| 15 & 20   | DI/BRZ   | 92,0            | 260,4 | 57,2 | 180,9 | 5,4         |
|           | CS/SS    | 92,0            | 260,4 | 57,2 | 180,9 | 5,9         |

• Mark 51, Flanged Ends, Metric

| Size (DN) | Flange PN | Dimensions (mm) |       |        |       |      |       | Weight (kg) |       |
|-----------|-----------|-----------------|-------|--------|-------|------|-------|-------------|-------|
|           |           | A1 <sup>1</sup> |       | B      |       | C    | D     | DI/BRZ      | CS/SS |
|           |           | DI/BRZ          | CS/SS | DI/BRZ | CS/SS | All  | All   |             |       |
| 15 & 20   | 10/16     | 244,4           | 244,4 | 260,4  | 260,4 | 57,2 | 180,9 | 11,8        | 11,8  |
|           | 25/40     | 260,4           | 260,4 | 260,4  | 260,4 | 57,2 | 180,9 | 13,2        | 13,2  |

Note: 1/4" & 3/8" utilize 1/2" body with reducer bushings.

# MARK 50 SELF-OPERATING BACK PRESSURE REGULATORS

## ORDERING SCHEMATIC

|          |  |          |  |          |          |          |          |          |          |          |          |           |
|----------|--|----------|--|----------|----------|----------|----------|----------|----------|----------|----------|-----------|
| <b>1</b> |  | <b>2</b> |  | <b>3</b> | <b>/</b> | <b>4</b> | <b>5</b> | <b>6</b> | <b>7</b> | <b>8</b> | <b>9</b> | <b>10</b> |
|          |  |          |  |          |          |          |          |          |          |          |          |           |

| 1    | Model           |  |  |
|------|-----------------|--|--|
| 50   | Standard        |  |  |
| 50HP | High Pressure   |  |  |
| 50QC | Quick Change    |  |  |
| 51   | Large Diaphragm |  |  |

| 2   | Size        |     |                                |  |
|-----|-------------|-----|--------------------------------|--|
|     | Inches (DN) |     | Inches (DN)                    |  |
| 025 | 1/4" (DN8)  | 150 | 1-1/2" (DN40)                  |  |
| 038 | 3/8" (DN10) | 200 | 2" (DN50)                      |  |
| 050 | 1/2" (DN15) | 250 | 2-1/2" (DN65) (MK50/50HP only) |  |
| 075 | 3/4" (DN20) | 300 | 3" (DN80) (MK50/50HP only)     |  |
| 100 | 1" (DN25)   | 400 | 4" (DN100) (MK50/50HP only)    |  |

MK51 available in 1/4" through 3/4" only.

| 3  | Body Material           |  |
|----|-------------------------|--|
| DI | Ductile Iron            |  |
| BR | Bronze (1/4" - 2")      |  |
| CS | Carbon Steel            |  |
| S6 | Stainless Steel         |  |
| CI | Cast Iron (2-1/2" - 4") |  |

| 4                 | End Connections                |  |
|-------------------|--------------------------------|--|
|                   | MK50/51, 1/4" - 2"             |  |
| PT                | NPT                            |  |
| BT                | BSPT                           |  |
| BP                | BSPP                           |  |
| SW                | FSW                            |  |
| F1                | 125#FE (Except IFE)            |  |
| I5                | 150# IFE                       |  |
| F5                | 150# FE (except IFE)           |  |
| F2                | 250# FE (except IFE)           |  |
| I3                | 300# IFE                       |  |
| F3                | 300# FE (except IFE)           |  |
| MK50, 2-1/2" - 4" |                                |  |
| I1                | 125# IFE                       |  |
| I5                | 150# IFE                       |  |
| I2                | 250# IFE                       |  |
| I3                | 300# IFE                       |  |
| I7                | PN 10 DIN IFE (CS/S6) DN15-150 |  |
| I6                | PN 16 DIN IFE (CS/S6) DN15-150 |  |
| I8                | PN 25 DIN IFE (CS/S6) DN15-150 |  |
| I4                | PN 40 DIN IFE (CS/S6) DN15-150 |  |

| 5  | Trim  |    |                        |
|----|-------|----|------------------------|
| S3 | 303SS | I3 | 303SSF/IFE (1/2" - 2") |
| S6 | 316SS | I6 | 316SSF/IFE (1/2" - 2") |

| 6 | Seat Material      |   |               |  |
|---|--------------------|---|---------------|--|
| A | 303SST (1/4" - 2") | V | 303SS/Jorcote |  |
| B | 316SST (1/4" - 2") | W | 316SS/Jorcote |  |

| 7 | Cv (Kv)     |                    |              |  |
|---|-------------|--------------------|--------------|--|
| 1 | 0.21 (0,28) | 9                  | 15 (12,93)   |  |
| 2 | 0.42 (0,36) | A                  | 25 (21,55)   |  |
| 3 | 0.84 (0,72) | B                  | 30 (25,86)   |  |
| 4 | 1.6 (1,38)  | D*                 | 55 (47,41)   |  |
| 5 | 2.5 (2,16)  | F*                 | 85 (73,28)   |  |
| 6 | 4.4 (3,79)  | G*                 | 115 (99,14)  |  |
| 7 | 6.4 (5,52)  | I*                 | 200 (172,41) |  |
| 8 | 9.5 (8,19)  | * 2-1/2" - 4" only |              |  |

| 8  | MK50/50QC Spring Range PSI (BAR) |             |                     |         |    |                   |
|----|----------------------------------|-------------|---------------------|---------|----|-------------------|
|    |                                  | 1/4" - 3/4" |                     | 1" - 2" |    | 2-1/2" - 4"       |
| 14 | 2-20 (0,14-1,38)                 | 03          | 1/2-4 (0,03-0,28)   |         | 22 | 4-15 (0,28-1,03)  |
| 34 | 10-30 (0,69-2,07)                | 06          | 2-6 (0,14-0,41)     |         |    |                   |
| 53 | 20-45 (1,38-3,10)                | 21          | 4-13 (0,28-0,90)    |         | 30 | 7-24 (0,48-1,65)  |
| 76 | 30-135 (2,07-9,31)               | 31          | 8-20 (0,55-1,38)    |         |    |                   |
| A4 | 80-185 (5,52-12,76)              | 50          | 15-80 (1,3-5,52)    |         | 52 | 16-30 (1,10-2,07) |
|    |                                  | 95          | 45-150 (3,10-10,34) |         |    |                   |

| 8  | MK50HP Spring Range PSI (BAR) |           |                   |             |  |
|----|-------------------------------|-----------|-------------------|-------------|--|
|    |                               | 1/2" - 2" |                   | 2-1/2" - 4" |  |
| A1 | 75-190 (5,17-13,10)           | 64        | 25-50 (1,72-3,45) |             |  |
| A7 | 100-320 (6,89-22,06)          | 82        | 40-80 (2,76-5,52) |             |  |
| A9 | 150-450 (10,34-31,02)         |           |                   |             |  |

| 8  | MK51 Spring Range PSI (BAR) |    |                     |  |
|----|-----------------------------|----|---------------------|--|
| 04 | 1/2-5 (0,03-0,34)*          | 62 | 20-70 (1,38-4,83)   |  |
| 08 | 2-10 (0,14-0,69)            | 86 | 40-105 (2,76-7,24)  |  |
| 14 | 2-20 (0,14-1,38)            | 69 | 25-150 (1,72-10,34) |  |
| 34 | 10-30 (0,69-2,07)           | 79 | 30-170 (2,07-11,72) |  |
| 54 | 20-50 (1,38-3,45)           |    |                     |  |

\* Must use elastomer diaphragm

| 9  | Diaphragm                       |  |
|----|---------------------------------|--|
| S6 | 316 SST (1/4" - 2" only)        |  |
| VI | Viton                           |  |
| BN | Buna-N (standard above 2"/DN50) |  |
| JL | Jorlon                          |  |

| 10 | Actuator                             |  |
|----|--------------------------------------|--|
| MD | for Metal Diaphragm (1/4" - 2" only) |  |
| ED | for Elastomer Diaphragm              |  |

# Mark 501/502 Series

## High Flow Back Pressure Regulators

The Mark 501 and 502 meet higher capacity requirements than standard back pressure regulators. The High Flow Mark 501 has Cv's as high as 50 (43Kv) and the Super High Flow Mark 502 has Cv's up to 70 (60,2 Kv). Each valve is standard with Jordan's Sliding Gate Seats, which helps to reduce the build-up commonly associated with high flow back pressure regulators.

Jordan's unique self-operated sliding gate back pressure regulator offers:

Shorter stroke than a globe or plug-style valve

- Faster response
- Smaller and lighter weight than globe-style valves
- Less build-up

Straight through flow

- Less turbulence, erosion and noise
- Improved rangeability
- Longer seat life

Ease of maintenance

- Interchangeable seats and Cv's
- Fewer spare parts
- Self-cleaning seats
- No gaskets or o-rings

### SPECIFICATIONS

**Sizes:** 1-1/2" & 2" (DN40 & DN50)

#### End Connections:

- Threaded (FNPT, BSPT, BSPP)
- ANSI Flanges (150#, 300#)
- DIN Flanges (PN10/16, PN25/40)

**Body Materials:** Ductile Iron, Bronze, Carbon Steel (A216 WCB), Stainless Steel (A351/CF8M)

#### Trim Materials:

- 303SST — Standard on Ductile Iron, Bronze, Carbon Steel valves
- 316SST — Standard on Stainless Steel Valves
- Monel, Hastelloy and other Alloys available
- 

#### Seat Materials:

- Jorcote on SST — Standard



#### Diaphragm Materials:

- Stainless Steel — standard
- Buna-N — optional
- Jorlon — optional
- Viton — optional

**Service:** Steam, water, oil, gas, air and chemicals

**Shutoff:** ANSI Class IV

**Reduced Pressure Control Ranges:** Select a range to match your setpoint. For optimal performance, your setpoint should fall in the upper portion of the selected range.

| Model     | Size (DN)                    | Spring Ranges |              |
|-----------|------------------------------|---------------|--------------|
|           |                              | PSI           | BAR          |
| 501 & 502 | 1-1/2" - 2"<br>(DN40 - DN50) | 0.5 - 4       | 0,03 - 0,28  |
|           |                              | 2 - 6         | 0,14 - 0,41  |
|           |                              | 4 - 13        | 0,28 - 0,90  |
|           |                              | 8 - 20        | 0,55 - 1,38  |
|           |                              | 15 - 80       | 1,03 - 5,52  |
|           |                              | 45 - 150      | 3,10 - 10,34 |

#### Cv Values & Maximum Differential Pressures

- Mark 501

| Cv (Kv)   | Size (DN)                 | Seat Material | Maximum ΔPSI (bar) |
|-----------|---------------------------|---------------|--------------------|
| 25 (21,5) | 1-1/2" & 2" (DN40 & DN50) | Jorcote       | 150 (10,34)        |
| 30 (25,8) | 1-1/2" & 2" (DN40 & DN50) | Jorcote       | 150 (10,34)        |
| 35 (30,1) | 1-1/2" & 2" (DN40 & DN50) | Jorcote       | 150 (10,34)        |
| 45 (38,7) | 1-1/2" (DN40)             | Jorcote       | 150 (10,34)        |
| 50 (43,0) | 2" (DN50)                 | Jorcote       | 150 (10,34)        |

- Mark 502

| Cv (Kv)   | Size (DN)     | Seat Material | Maximum ΔPSI (bar) |
|-----------|---------------|---------------|--------------------|
| 65 (55,9) | 1-1/2" (DN40) | Jorcote       | 150 (10,34)        |
| 70 (60,2) | 2" (DN50)     | Jorcote       | 150 (10,34)        |

**DIMENSIONS — MK501/502**

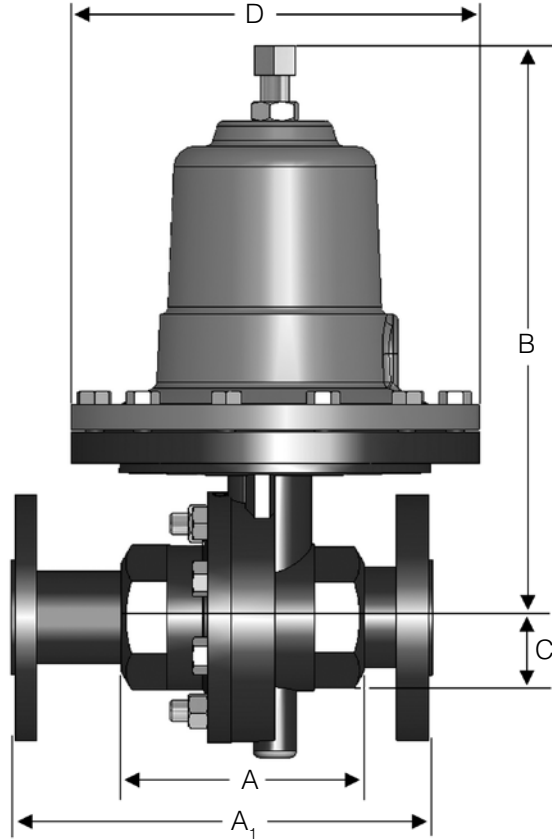

- Mark 501/502: Threaded & FSW Ends

| Size           | Material | Dimensions (inches) |       |      |      | Weight (lbs.) |
|----------------|----------|---------------------|-------|------|------|---------------|
|                |          | A                   | B     | C    | D    |               |
| 1-1/2"<br>- 2" | DI/BRZ   | 4.50                | 10.25 | 2.75 | 7.09 | 26            |
|                | CS/SS    | 5.50                | 11.00 | 2.75 | 7.09 | 35            |

- Mark 501/502: Threaded & FSW Ends, Metric

| Size (DN) | Material | Dimensions (mm) |     |    |     | Weight (kg) |
|-----------|----------|-----------------|-----|----|-----|-------------|
|           |          | A               | B   | C  | D   |             |
| 40 - 50   | DI/BRZ   | 114             | 260 | 70 | 180 | 11,8        |
|           | CS/SS    | 140             | 279 | 70 | 180 | 15,9        |

- Mark 501/502, Flanged Ends

| Size   | ANSI Flange | Dimensions (inches) |        |        |       |      |      | Weight (lbs.) |       |
|--------|-------------|---------------------|--------|--------|-------|------|------|---------------|-------|
|        |             | A1                  |        | B      |       | C    | D    | DI/BRZ        | CS/SS |
|        |             | DI/BRZ              | CS/SS  | DI/BRZ | CS/SS | All  | All  |               |       |
| 1-1/2" | 150#        | 10.00*              | 10.00* | 10.25  | 11.22 | 2.31 | 7.09 | 42            | 46    |
|        | 300#        | 10.25*              | 10.25* | 10.25  | 11.22 | 2.31 | 7.09 | 45            | 52    |
| 2"     | 150#        | 10.00               | 10.00  | 10.25  | 11.42 | 2.75 | 7.09 | 46            | 50    |
|        | 300#        | 10.50               | 10.50  | 10.25  | 11.42 | 2.75 | 7.09 | 49            | 55    |

\* Not IFE. Not ANSI Standard.

- Mark 501/502, Flanged Ends, Metric

| Size (DN) | Flange PN | Dimensions (mm) |       |        |       |      |     | Weight (kg) |       |
|-----------|-----------|-----------------|-------|--------|-------|------|-----|-------------|-------|
|           |           | A1              |       | B      |       | C    | D   | DI/BRZ      | CS/SS |
|           |           | DI/BRZ          | CS/SS | DI/BRZ | CS/SS | All  | All |             |       |
| 40        | 10/16     | 254             | 254   | 279    | 285   | 58,7 | 180 | 19,1        | 20,9  |
|           | 25/40     | 260             | 260   | 279    | 285   | 58,7 | 180 | 20,4        | 23,6  |
| 50        | 10/16     | 254             | 230   | 279    | 290   | 69,9 | 180 | 20,9        | 22,7  |
|           | 25/40     | 267             | 230   | 279    | 290   | 69,9 | 180 | 22,2        | 24,9  |

ORDERING SCHEMATIC

|          |   |          |   |          |   |          |          |          |          |          |          |           |           |           |
|----------|---|----------|---|----------|---|----------|----------|----------|----------|----------|----------|-----------|-----------|-----------|
| <b>1</b> | — | <b>2</b> | — | <b>3</b> | / | <b>4</b> | <b>5</b> | <b>6</b> | <b>7</b> | <b>8</b> | <b>9</b> | <b>10</b> | <b>11</b> | <b>12</b> |
|----------|---|----------|---|----------|---|----------|----------|----------|----------|----------|----------|-----------|-----------|-----------|

| <b>1</b> | <b>Model</b>    |  |
|----------|-----------------|--|
| 501      | High Flow       |  |
| 502      | Super High Flow |  |

| <b>6</b> | <b>Seat Material</b> |  |
|----------|----------------------|--|
| V        | 303SS/Jorcote        |  |
| W        | 316SS/Jorcote        |  |

| <b>2</b> | <b>Size</b>        |  |
|----------|--------------------|--|
|          | <b>Inches (DN)</b> |  |
| 150      | 1-1/2" (DN40)      |  |
| 200      | 2" (DN50)          |  |

| <b>7</b> | <b>Cv (Kv)</b> |  |
|----------|----------------|--|
| A        | 25 (22)        |  |
| B        | 30 (26)        |  |
| V        | 35 (30)        |  |
| W        | 45 (39)        |  |
| C        | 50 (43)        |  |
| Y        | 65 (56)        |  |
| E        | 70 (60)        |  |

| <b>3</b> | <b>Body Material</b> |  |
|----------|----------------------|--|
| DI       | Ductile Iron         |  |
| BR       | Bronze               |  |
| CS       | Carbon Steel         |  |
| S6       | Stainless Steel      |  |

| <b>8</b> | <b>Range</b>            |  |
|----------|-------------------------|--|
| 03       | 0.5 - 4 (0,03 - 0,28)   |  |
| 06       | 2 - 6 (0,14 - 0,41)     |  |
| 21       | 4 - 13 (0,28 - 0,90)    |  |
| 31       | 8 - 20 (0,55 - 1,38)    |  |
| 50       | 15 - 80 (1,03 - 5,52)   |  |
| 95       | 45 - 150 (3,10 - 10,34) |  |

| <b>4</b> | <b>End Connections</b> |  |
|----------|------------------------|--|
| PT       | NPT                    |  |
| BT       | BSPT                   |  |
| I5       | 150# IFE CS or SST*    |  |
| F5       | 150# FE DI or BR       |  |
| I7       | PN10 IFE CS or SST*    |  |
| F7       | PN10 FE DI or BR       |  |
| I6       | PN16 IFE CS or SST*    |  |
| F6       | PN16 FE DI or BR       |  |
| BP       | BSPP                   |  |
| SW       | FSW                    |  |
| I3       | 300# IFE CS or SST*    |  |
| F3       | 300# FE DI or BR       |  |
| I8       | PN25 IFE CS or SST*    |  |
| F8       | PN25 FE DI or BR       |  |
| I4       | PN40 IFE CS or SST*    |  |
| F4       | PN40 FE DI or BR       |  |

| <b>9</b> | <b>Diaphragm</b> |  |
|----------|------------------|--|
| S6       | 316 SST          |  |
| VI       | Viton            |  |
| BN       | Buna-N           |  |
| JL       | Jorlon           |  |

| <b>10</b> | <b>Actuator</b>         |  |
|-----------|-------------------------|--|
| MD        | for Metal Diaphragm     |  |
| ED        | for Elastomer Diaphragm |  |

\* IFE (integral flanged end) for 2" only.  
FE is threaded or weld flanges.

| <b>11</b> | <b>Double Bolting</b> |  |
|-----------|-----------------------|--|
| 00        | None                  |  |
| ZZ        | Non-Standard          |  |

| <b>5</b> | <b>Trim</b> |  |
|----------|-------------|--|
| S3       | 303SS       |  |
| S6       | 316SS       |  |
| I3       | 303SSF/IFE  |  |
| I6       | 316SSF/IFE  |  |

| <b>12</b> | <b>Accessories</b>     |  |
|-----------|------------------------|--|
| 0         | None                   |  |
| 6         | 316 SS Bolting         |  |
| 7         | Hi-Temperature Bolting |  |
| Z         | Non-Standard           |  |

