

G-Series Pneumatic and Hydraulic Actuators

The Compact, Lightweight and Reliable Solution



BETTIS

EMERSON[™]
Process Management

G-Series: A New Generation of Actuators

Compact

Lightweight

Efficient

Reliable

Key Features

- Symmetric or Canted Yoke
- Modular Design
- PED 97/23/EC Compliant
- SIL 3 Suitability
- ATEX Certified
- Water Ingress Protected
- Five-Year Warranty

Bettis® G-Series Robotarm II™ valve actuators from Emerson Process Management represent the high quality and ingenuity operators have come to expect from Bettis products since pioneering actuator technology more than 50 years ago. The G-Series provide a highly unique and reliable means of operating ball, butterfly or plug valves as well as louvers, dampers and other 90 degree rotating mechanisms.

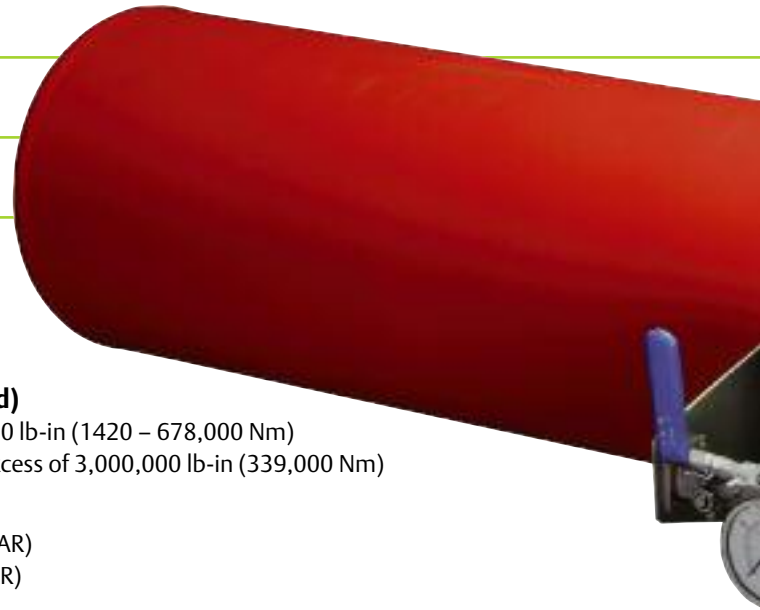

Operating Ranges

Torque Outputs (guaranteed)

Double-acting: 12,581-6,000,000 lb-in (1420 – 678,000 Nm)

Spring-return end torques : In excess of 3,000,000 lb-in (339,000 Nm)

Operating Pressures

Pneumatic: 40-200 PSIG (3-14 BAR)

Hydraulic: To 5000 PSIG (345 BAR)

Operating Temperatures

Standard: -20° F to +200° F (-29° C to +93° C)

Optional Trims:

High Temperature (-10 trim): 0° F to +350° F (-18° C to +177° C)

Low Temperature (-11 trim): -40° F to +150° F (-40° C to + 66° C)

High Cycle Standard Temperature (-33 trim): -20° F to +200° F (-29° C to +93° C)

Non – PED Low Temperature :

Pneumatic: -50° F to +180° F (-46° C to +82° C)

Hydraulic: -50° F to +200° F (-46° C to +93° C)

Benefits

Created with its users' interest in mind, the G-Series actuators offer many significant benefits. Among these are:

- **Compact** – G-Series actuators optimize the center of gravity location. They are significantly lighter and require less space than do other actuators of equal or less torque output – approximately 1/3 lighter and 1/3 smaller.
- **Water Ingress Protected** – G-Series actuators meet both IP 66 and IP 67M specifications for submergence and severe high pressure water deluge test. The actuator has no gaskets and is totally o-ring sealed.
- **Wear Resistant** – The Powr-Swivl™ piston rod and guide block connection, superior surface finishes and self-lubricating bearings maximize input energy transfer directly to the valve stem. Efficiency is further enhanced by the tension-loaded spring, minimizing radial loads on the piston rod.
- **Corrosion Resistant** – With protective internal and external coatings, the G-Series performs reliably in harsh environments, as confirmed by salt spray tests per ASTM B117 criteria.

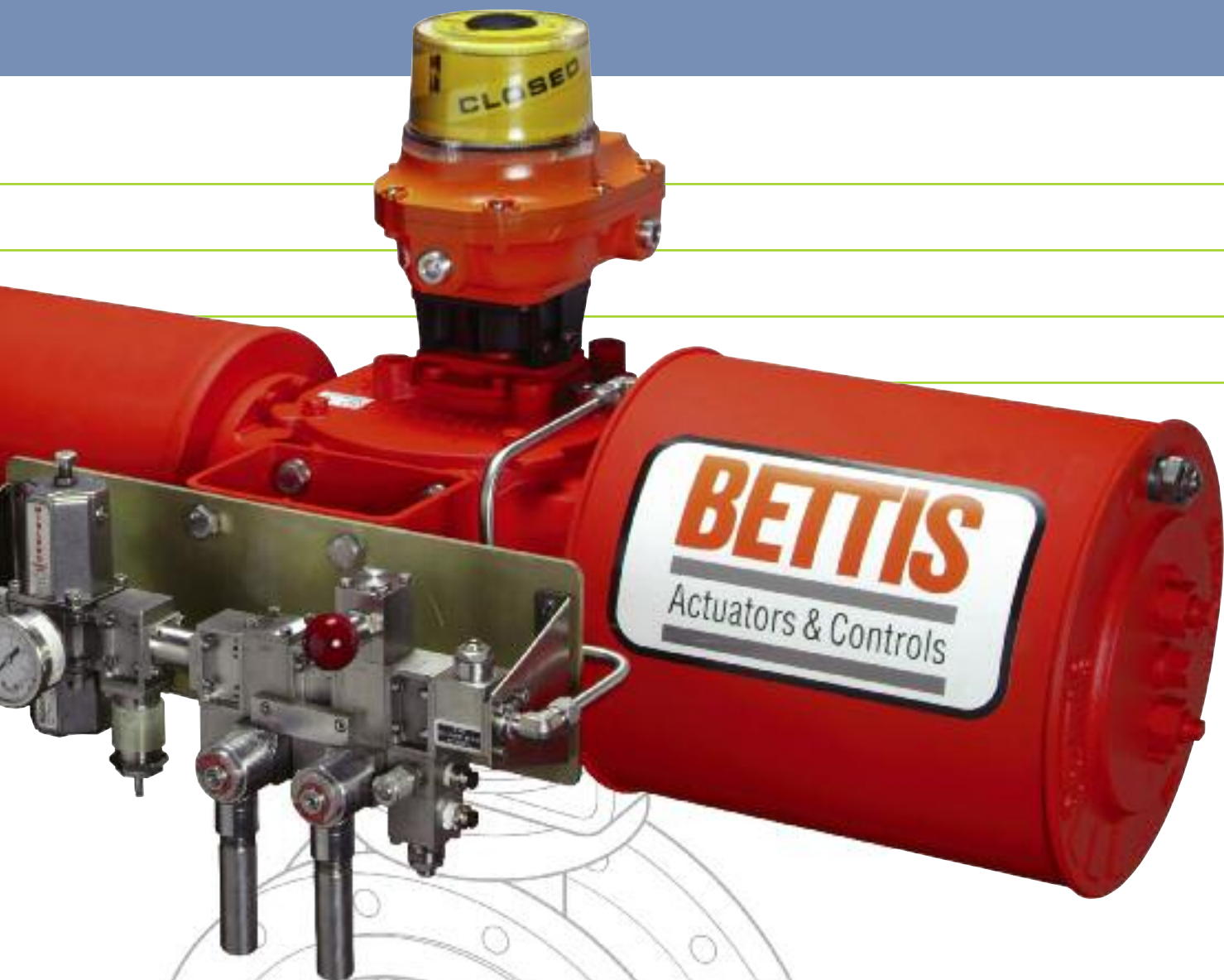

- **Symmetric or Canted Yoke** – G-Series actuators, with their scotch yoke design, are available with either symmetric or canted yokes, depending on break torque requirements.
- **Modular Design** – G-Series actuators have available, field-serviceable drive, power, spring and override modules. The modules are removable, serviceable and interchangeable while mounted to the valve. Modules are available for separate purchase to reduce spare parts inventory (See page 8 for further details).
- **Safety** – The patented Tension-Lok™ allows the safe installation and removal of the spring module in a manner that eliminates accidental release of the spring force and reduces potential for incorrect installation, operation or misapplication of a reconfigured actuator.
- **Industry Leading Warranty** – G-Series actuators are backed by a five year materials and workmanship warranty – the industry's best.
- **Standardized** – The shaft driven accessory interface conforms to NAMUR and is identical on all G-Series models, allowing standardization of accessory mounting hardware and installation practices.
- **Versatile** – The G-Series actuator power and spring modules can interchange easily, allowing for quick reversal of the fail-safe mode, while allowing the addition of overrides, accessories and other modules (See page 8 for further details).
- **MSS or ISO Valve Mounting** – The G-Series valve interface meets the dimensional requirements of MSS SP-101 or ISO 5211 defined for each torque range.

Design Features Offer Unique Benefits

1 Safe Spring Lock

Mechanism – Tension-Lok™ positively locks the spring module in place under load. Prevents spring module detachment from the drive module unless it is taken to a safe condition.

2 Reduced Wear – Powr-Swivl™ connects the piston rod with the guide block, compensating for side load deflection and reducing wear on rod, bearings and seals (not available in G1 models).

3 Positive Yoke Seal – Acculine™ shaft drive assures a positive yoke seal, maintains and eliminates accessory shaft side loads which helps maintain device integrity and prevents unintentional disengagement of critical signal devices or controls.

4 Standardized Mounting – The NAMUR mounting configuration allows standardization of mounting hardware for a wide range of shaft-driven accessories.

5 Replaceable Bearings – Protect sliding and rotating components, with suitability for either dry or lubricated working conditions.

6 Better Alignment – Guide Block Thrust Bushing aligns the guide block within the yoke arms to enhance the Powr-Swivl function.

7 Reduced Axial Movement – Non-metallic thrust bar prevents yoke pin axial movement, transferring axial loads directly to the drive module case.

8 Internally Mounted Optional Overrides – Hydraulic override cylinder module for spring-return models doesn't increase actuator length. Design positively separates power and override fluids. Options include speed controls, special trims, and pilot signal or power gas auto-disengage.

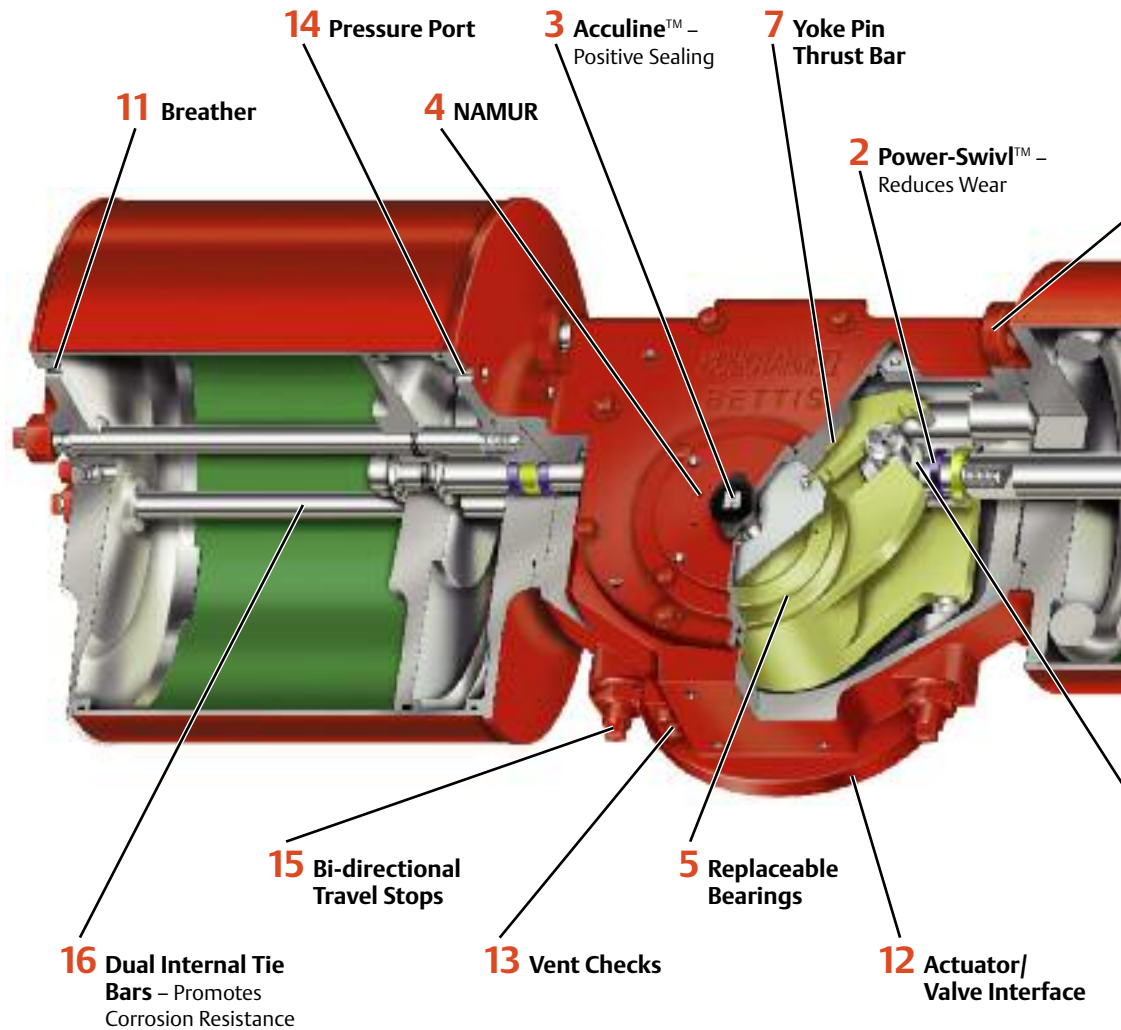

9 Corrosion Resistant Spring Module – Guided by self-lubricating alignment bearings. Fully enclosed and supporting Tension-Lok, prevents potential operating personnel injury or equipment damage. Corrosion resistant to harshest environments.

10 Easy Lifting – G4 and larger models equipped with eight lifting eyes for safe actuator handling in three major planes during shipping, installation and removal.

11 Environmental Sealing – Breather seals out environment, meeting IP 67M criteria. Normally closed 316 SS normally closed breather allows pressure equalization during operation.

12 Accurate Drive Alignment – Actuator/Valve Interface with optional centering ring, assures accurate alignment of output drive and valve stem. Female drive, with full length keyed connection, allows for valve/actuator mounting in a variety of orientations, when specified.

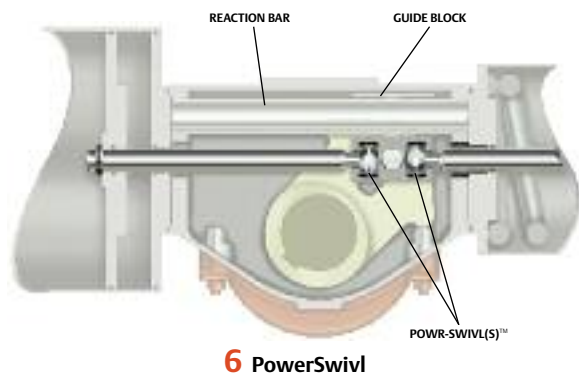
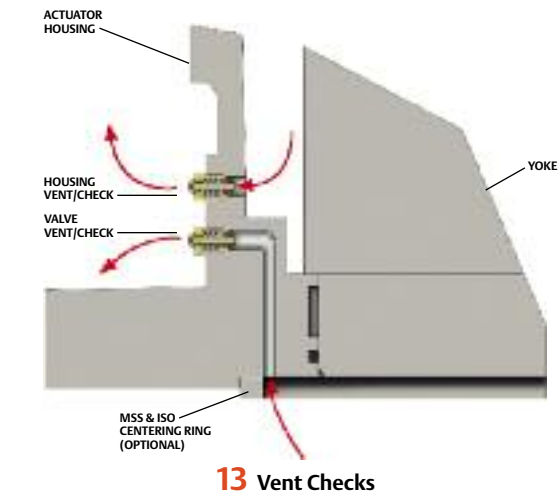
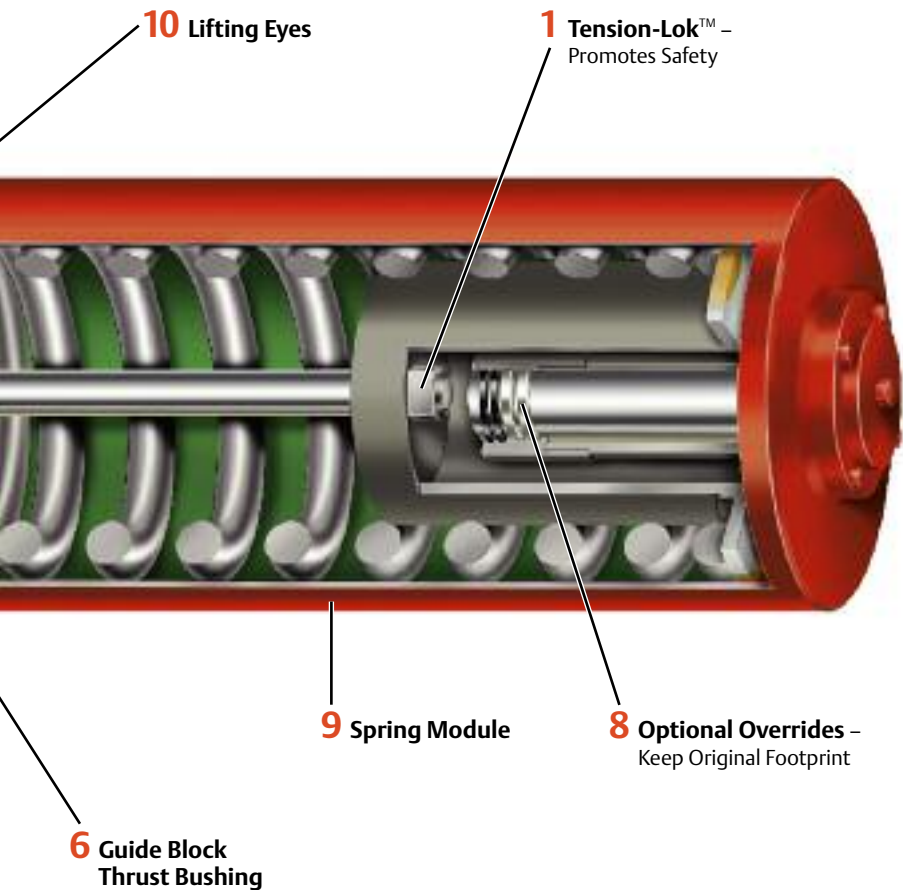

1 Tension-Lok™ – Promotes Safety

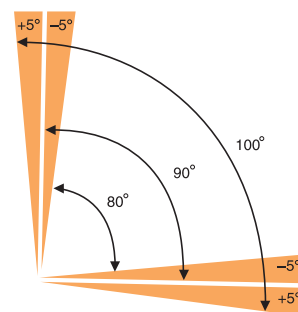

Bi-directional Travel Limits

13 Better Sealing – Vent Checks – Two drive module vent checks release overpressure and seal, preventing dust, corrosive atmospheres and water ingress. Lower vent isolates valve stem leakage and provides a means of attaching fugitive emissions monitoring devices.

14 Reduced Tubing Exposure – Inboard port location minimizes exposure of supply tubing, reducing opportunity for mechanical damage on spring-return units. Pneumatic and hydraulic units have NPT ports. Consult factory for options.

15 Full Travel Adjustment – Bi-Directional Travel Stops integral to the actuator, the stops allow 80° to 100° total travel adjustment. Cylinder-mounted extended travel stops are optional.

16 Corrosion Resistant Tie Bars – Featured on pneumatic power modules, the tie bars are protected from corrosion and physical damage. Also center the piston in the cylinder bore to prevent metal-to-metal contact.

Modular Versatility

- Enables Online Field Maintenance
- Lowers Inventory

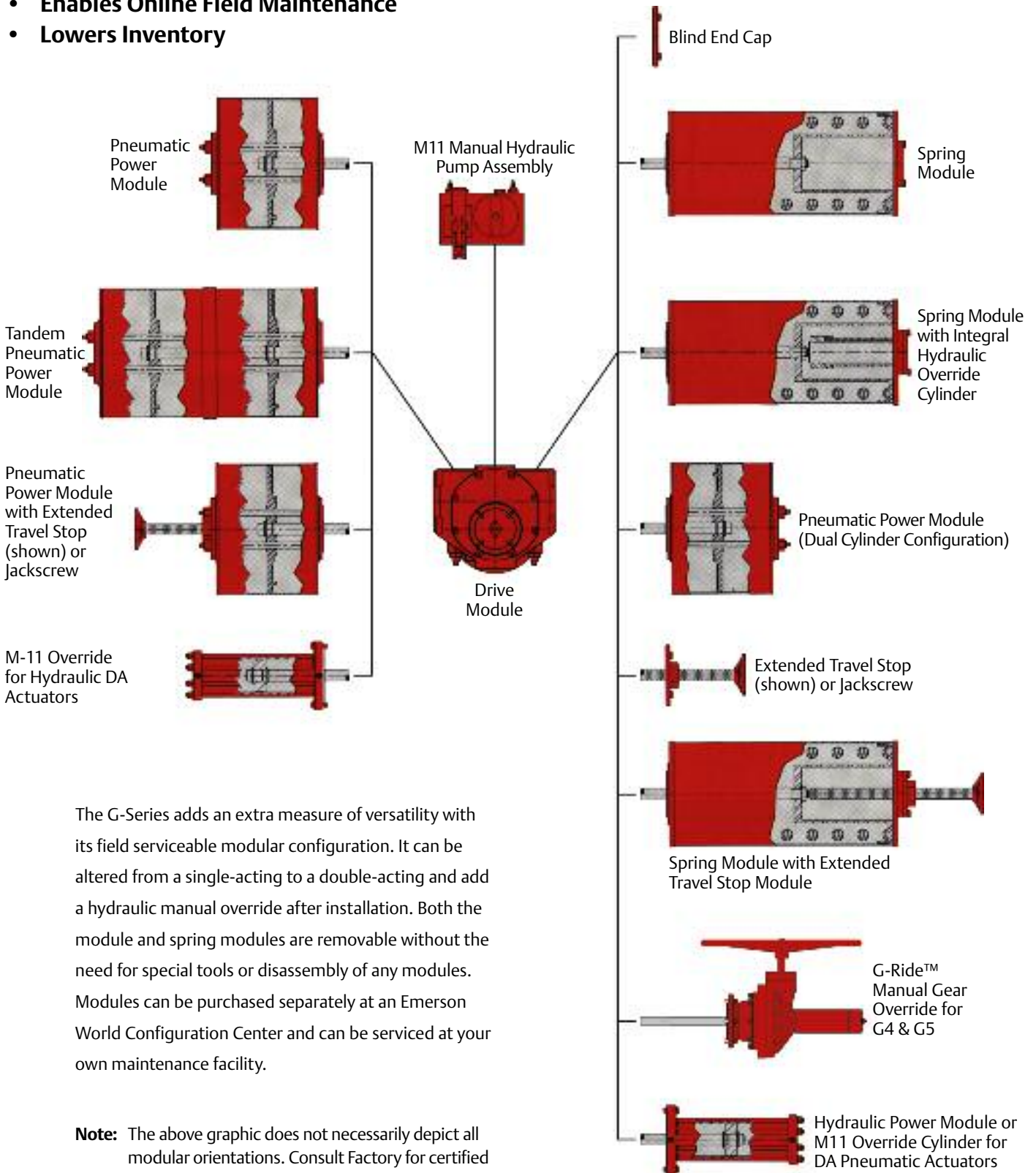

The G-Series adds an extra measure of versatility with its field serviceable modular configuration. It can be altered from a single-acting to a double-acting and add a hydraulic manual override after installation. Both the module and spring modules are removable without the need for special tools or disassembly of any modules. Modules can be purchased separately at an Emerson World Configuration Center and can be serviced at your own maintenance facility.

Note: The above graphic does not necessarily depict all modular orientations. Consult Factory for certified dimensional drawings.

G-Series Product Families

Choices to suit your requirements

Symmetric or Canted

The scotch yoke mechanism converts the actuator's linear piston movement into a rotary motion. Bettis G-Series actuators are available with symmetric or canted yokes. Symmetric yokes are used when requirements call for efficient operation at both the break and end positions. Canted (or inclined) yokes have a torque advantage in applications where the break torque requirements are needed at the unseating of the valve and less critical at the run or full open positions. The following graph illustrates the torque output curves for an identical actuator using either symmetric or canted yokes.

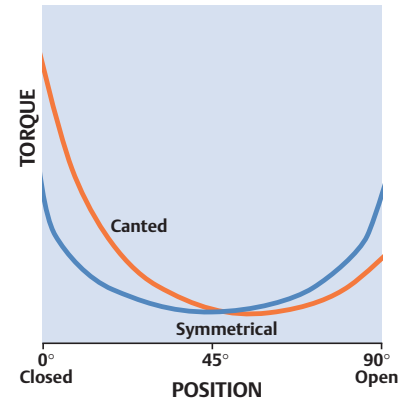

Symmetric Yoke



Canted Yoke

GH-Series

The Bettis GH Series is a specialized solution for applications where higher maximum operating pressures (MOP) are required, yet where cycle life is not a predominant requirement. The GH-Series actuators are available in either canted or symmetric yoke configurations for spring-return, fail-safe projects. GH and GHC (canted yoke) models are available with an optional high strength SR0 spring allowing higher spring start and end torques. A complete torque listing for both clockwise (CW) and counter clockwise (CCW) operation is available in the Bettis Technical Data Book.

Model Availability

Actuator Model	G-Series Symmetric Yoke		GC-Series Canted Yoke		GH/GHC-Series Higher MOP		GH/GHC-Series SR0 Spring (optional)	
	DA	SR	DA	SR	DA	SR	DA	SR
G01	X	X	-	-	-	-	-	-
G2	X	X	-	-	-	X	-	X
G3	X	X	-	-	-	X	-	X
G4	X	X	X	X	-	X	-	X
G5	X	X	X	X	-	X	-	X
G7	X	X	X	X	-	X	-	X
G8	X	X	X	X	-	X	-	X
G10	X	X	X	X	-	-	-	-
G13	X	X	-	-	-	-	-	-

X= available

Assembly Drawing

G-Series Spring-Return Pneumatic

(also available in double-acting type)

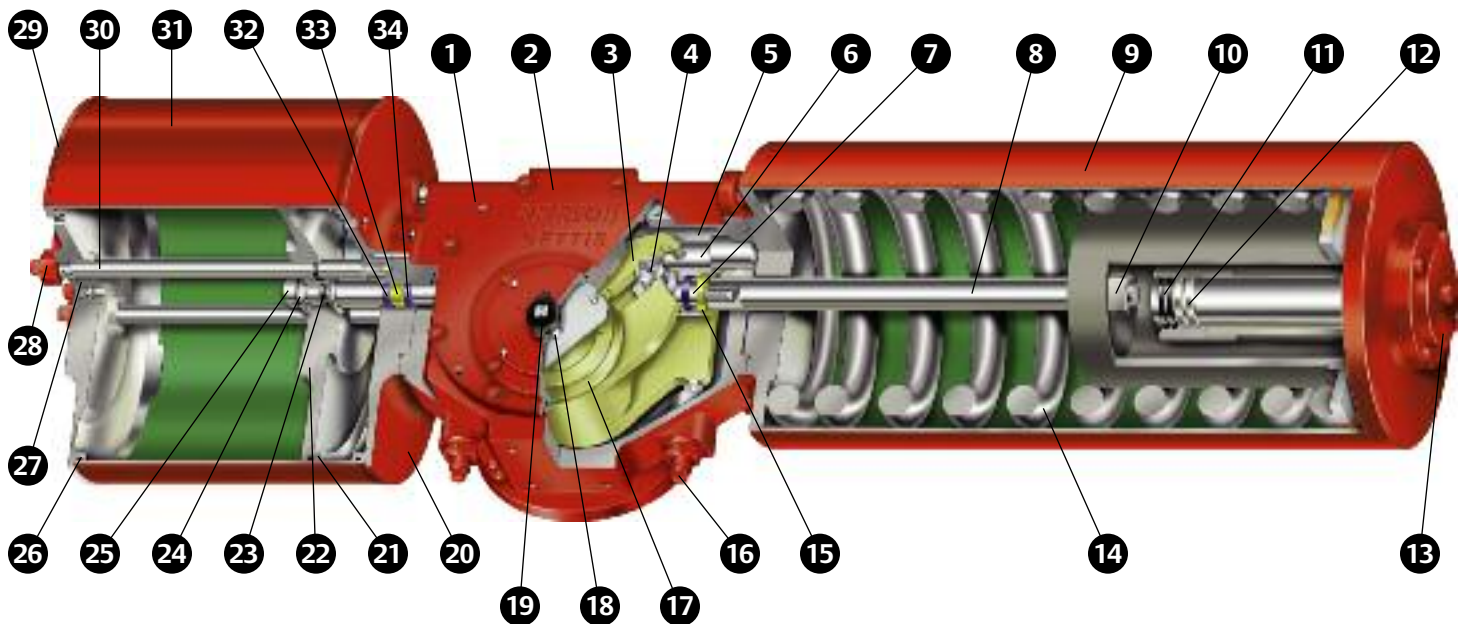

No.	Part	Material
1	Housing	Ductile Iron
2	Cover	Ductile Iron
3	Yoke	Ductile Iron
4	Yoke Pin	Alloy Steel
5	Guide Block	Ductile Iron
6	Guide Bar	Alloy Steel
7	Extension Rod Assy	Alloy Steel
8	Tension Rod	Alloy Steel
9	Spring Cylinder	Carbon Steel
10	Tension Lok	Alloy Steel
11	O-Ring Seal	Nitrile
12	Hydraulic Override Assembly	Carbon Steel
13	Cover Plate for Spring Can	Carbon Steel
14	Spring	Alloy Steel
15	Extension Retainer	Alloy Steel
16	Stop Screw	Alloy Steel
17	Yoke Pin Bearing	DU Bearing
18	Thrust Washer	Delrin
19	Position Indicator	Polyamide 6
20	Inner End Cap	Ductile Iron
21	Piston Seal	Nitrile
22	Piston	Ductile Iron
23	O-Ring Seal	Nitrile
24	Retainer Ring	Stainless Steel
25	Piston Rod	Alloy Steel
26	O-Ring Seal	Nitrile
27	Pipe Plug	Carbon Steel
28	Hex Nut	Alloy Steel
29	End Cap	Ductile Iron
30	Tie Bar	Alloy Steel
31	Piston Cylinder	Carbon Steel
32	Polypak Seal	Urethane Impregnated
33	Rod Bushing	Delrin
34	Rod Wiper	Urethane Impregnated

Assembly Drawing

G-Series Spring-Return Hydraulic (also available in double-acting type)

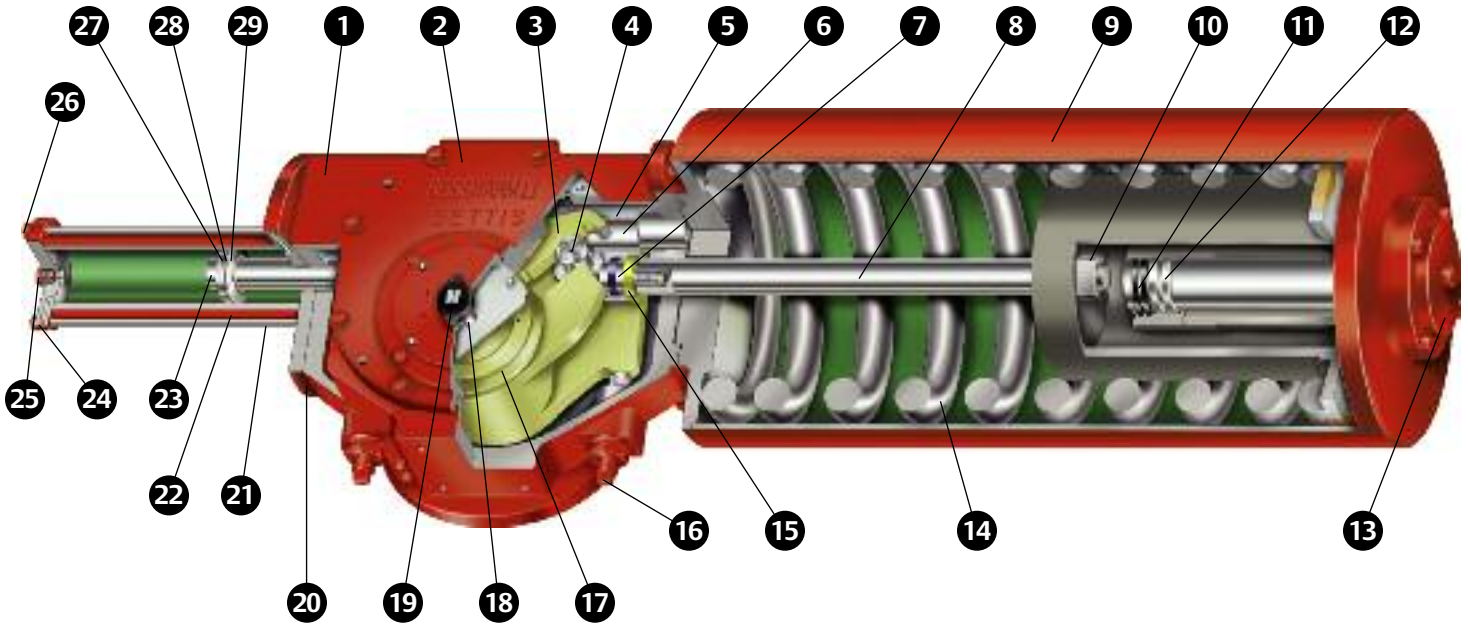

No.	Part	Material
1	Housing	Ductile Iron
2	Cover	Ductile Iron
3	Yoke	Ductile Iron
4	Yoke Pin	Alloy Steel
5	Guide Block	Ductile Iron
6	Guide Bar	Alloy Steel
7	Extension Rod Assembly	Alloy Steel
8	Tension Rod	Alloy Steel
9	Spring Cylinder	Carbon Steel
10	Tension Lok	Alloy Steel
11	O-Ring Seal	Nitrile
12	Hydraulic Override Assembly	Carbon Steel
13	Cover Plate for Spring Can	Carbon Steel
14	Spring	Alloy Steel
15	Extension Retainer	Alloy Steel
16	Stop Screw	Alloy Steel
17	Yoke Pin Bearing	DU Bearing
18	Thrust Washer	Delrin
19	Position Indicator	Polyamide 6
20	Inner End Cap	Carbon Steel
21	Tie Bar	Alloy Steel
22	Hydraulic Cylinder	Carbon Steel
23	Piston Rod	Alloy Steel
24	O-Ring Seal	Nitrile
25	Pipe Plug	Carbon Steel
26	Hex Nut	Alloy Steel
27	Polypak Seal	Urethane Impregnated
28	Piston Bearing	Polyethylene
29	Piston	Carbon Steel

Options

M11 – This hydraulic manual override is a compact modular system designed for use with all G-Series actuators. The override can be used on either spring-return or double-acting models and can be applied to pneumatic or hydraulic units. Remote mount units are available, consult factory.



M3/M3HW – This Jackscrew manual override is a mechanical advantage device threaded through a special adapter or the end cap of the G-Series cylinder to exert linear thrust on the actuator's piston rod. The Jackscrew override is available for G1, 2 or 3 models with or without handwheel.

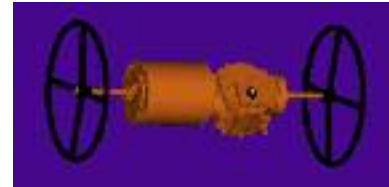

G-Ride – This economical mechanical override can be used with G4 and G5 spring-return models. The external, non-declutchable gearbox override can be supplied with a standard hex drive or optional handwheel. The G-Ride is modular as a bolt-on attachment to the spring cartridge for field modification.



BettiStop™ Partial Stroke Test Device – This external-mount device is sandwiched between the G-Series actuator and the valve. It is ideal for periodic testing of Emergency Shutdown valves (ESD) while remaining in service and is used for other safety process flow applications. It is particularly useful where compliance with ISA S84.01 and IEC 61508/61511 are applicable.

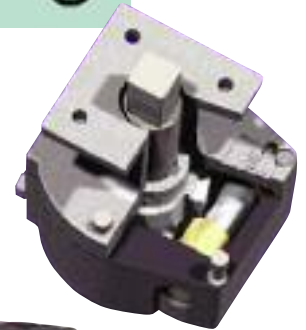

The BettiStop can test a valve automation package by mechanically limiting valve stem rotation, clockwise or counter-clockwise, to 20 degrees as standard or 15 degrees optionally. When disengaged, the BettiStop does not interfere with the actuated valve.

SIL-PAC™ – The unique SIL-PAC solution provides a complete hardware and Bettis-supplied documentation package, embracing IEC, ISA and OSHA standards, for use in a SIL application. The G-Series actuators have a Failure Modes and Effects Diagnostics Analysis (FMEDA) report performed by Exida.com™ for SIL suitability. They can be combined with other components such as solenoid valves, switches and regulators. When Fisher's TÜV-certified FIELDVUE® DVC controller is added, SIL-PAC is capable of partial stroke testing PLUS providing continuous monitoring of supply pressure, valve position and pressure values to the actuator to verify its proper working condition. The SIL-PAC package can then be mounted on the appropriate quarter-turn valve for SIL1, 2 or 3 applications.



BettiSystems™ – Bettis has pre-engineered and documented a series of commonly required control systems. These approved systems utilize standard components, reduce lead times, and simplify purchasing, installation and start-up. Please consult the factory for additional information.



Specification Guide

The following guide develops a comprehensive, performance oriented pneumatic and hydraulic actuator and control specification. Bettis' G-Series actuators meet or exceed all requirements outlined below for Quarter-turn (90°) valve operation.

1. The actuator shall be scheduled maintenance free, fully resistant to environmental, power gas, and load conditions.
2. The actuator shall be a true modular design to simplify field service, interchangeability of the power and spring modules, and the addition of manual overrides and accessories.
3. The actuator shall meet all applicable design codes, safety restrictions, and application practices including SI 1029 regulations, IP 66 and IP 67M type testing.
4. The power and spring modules shall be rigidly attached by external bolting to the drive module without requiring special tools, disassembly, or disturbance of seals of any module.
5. The pneumatic power module shall be constructed with dual internal tie bars of high strength alloy steel protected by corrosion and wear resistant coatings. Power modules shall be constructed to allow pressure testing independent of the drive module.
6. The reaction bar shall be corrosion and wear protected by a chemical bath surface conversion process applied in accordance with Bettis' ESC 20 specification, and shall exhibit a minimum surface hardness of 60 Rc.
7. The actuator shall be produced, service rated and auditable to a written Quality Assurance Program complying with ISO 9001, 10CFR50 Appendix B, CSA Z-299, and when specified, DIN 50049 3.1.b.
8. All actuators and modules shall meet acceptance criteria defined by Bettis' ES-6 test specification latest revision or equivalent prior to shipment.
9. The valve drive interface shall meet the applicable requirements of MSS SP-101 or ISO 5211 Standards.
10. The actuator shall be provided with a full length keyed female drive connection suitable for mounting in multiple orientations, as specified.
11. The actuator shall be service rated based upon load and application parameters, auditable to accelerated wearage test data.
12. All external bolting shall be blind tapped to protect the threads and positively prevent water ingress as defined by the requirements of IP 66 and IP 67M. Sheet or fibrous gaskets shall not be used for pressure or environmental seals.
13. Accessory drive shaft shall be bearing centered, with respect to the mounting pattern and isolated from any axial or radial yoke movements.
14. All shaft driven control and signal devices shall be protected from mechanical damage by a bearing centered shaft drive meeting NAMUR dimensional specifications. Device attachment shall be identical and interchangeable between all models.
15. Spring and drive module interface are to be positively retained under all operating conditions.
16. Safe spring module installation/removal shall be inherent within the spring attachment design and shall not require special tools. The locking mechanism shall be self-engaging and highly visible during assembly, assuring that the lock position is attained. The mechanism shall positively disallow spring module detachment while in a loaded condition.
17. The spring module shall be fully enclosed, o-ring sealed and welded.
18. The spring and spring retainer shall be self-centered and bearing guided within the spring module.
19. All module interfaces shall include a precision machine pilot to ensure accurate alignment.
20. The spring-return actuator shall utilize an inherently guided tension rod to energize the compression spring eliminating the need for tie bars.
21. Each actuator shall be fitted with two (2) 316 stainless steel, normally closed vent-checks. The single-acting actuator power module shall incorporate a 316 stainless steel bi-directional breather/vent.
22. The piston rod guide block connection shall compensate for angular and lateral deflection.
23. The piston rod shall be detachable from the drive module without the need of special tools or module disassembly.
24. Replaceable bearings shall exhibit documented, extended wear capabilities and shall be suitable for dry or lubricated working conditions. Sliding and rotating ferrous metal surfaces shall be protected by suitable bearings to control wear.
25. Metallic coating of pressure containing and load bearing surfaces which can be scratched, cracked, or peeled are prohibited.
26. All contact surfaces of the guide block assembly shall incorporate replaceable bearings and a rigid rotating pin torque transfer mechanism.
27. The yoke pin shall rotate in a self-lubricating bearing to eliminate sliding friction in the yoke slots and shall be retained by stationary non-metallic thrust bars.
28. The manufacturer shall provide a five-year materials and workmanship warranty.
29. Integral bi-directional travel stops shall allow 80° to 100° total travel adjustment.
30. The construction of the actuator shall be suitable for continuous exposure to ambient temperatures of -20°F to +200°F (-29°C to +93°C). Optional low temperature and high temperature trim are available.
31. Standard valve position stops shall provide 80–100° adjustment and be capable of stalling the actuator at the maximum torque output.

Ordering / Model Designation

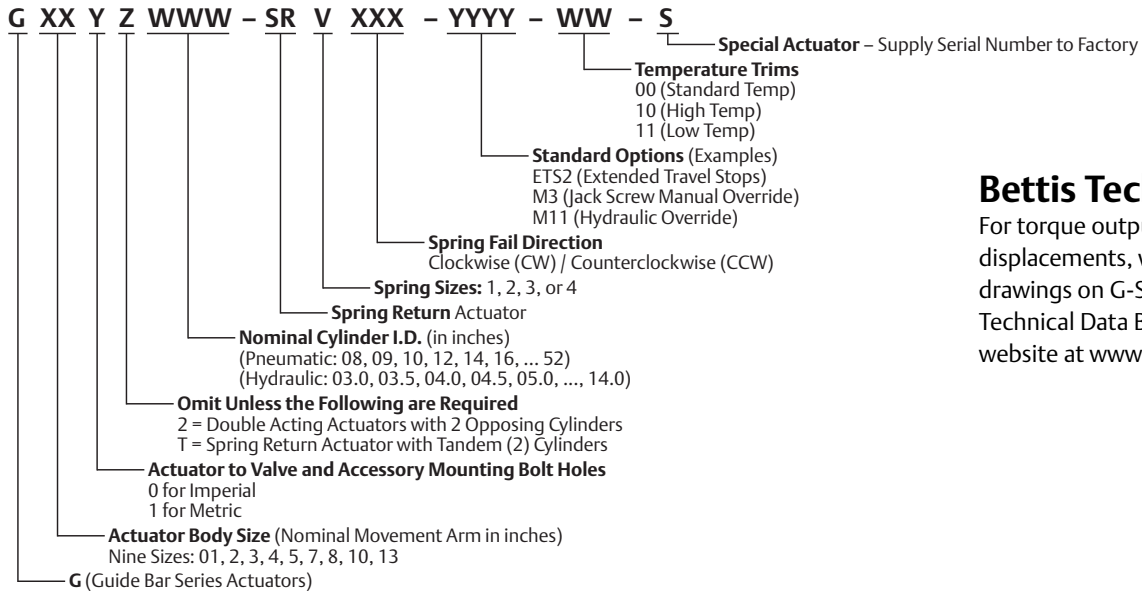

Bettis Technical Data

For torque outputs, sizing information, displacements, weights and dimensional drawings on G-Series, see Bettis' Technical Data Brochure or visit our website at www.bettis.com.

Contact Us: Emerson Process Management, Valve Automation facilities at your nearest location:

North & South America

18703 GH Circle
PO Box 508
Waller, Texas 77484
USA
T +1 281 727 5300
F +1 281 727 5353

2500 Park Avenue West
Mansfield, Ohio 44906
USA
T +1 419 529 4311
F +1 419 529 3688

9009 King Palm Drive
Tampa, Florida 33619
USA
T +1 813 630 2255
F +1 813 630 9449

4112-91A Street
Edmonton, Alberta T6E5V2
Canada
T +1 780 450 3600
F +1 780 450 1400

Av. Hollingsworth, 325
Iporanga
Sorocaba, SP 18087-105
Brazil
T +55 15 3238 3788
F +55 15 3228 3300

Europe

Asveldweg 11
7556 BT Hengelo(O)
The Netherlands
T +31 74 256 1010
F +31 74 291 0938

Siemensring 112
D-47877 Willich
Germany
T +49 2154 499 660
F +49 2154 499 6613

30/36 Allee du Plateau
93250 Villemomble
France
T +331 48 122610
F +331 48 122619

6 Bracken Hill
South West Industrial Estate
Peterlee, Co Durham
SR82LS, United Kingdom
T +44 191 518 0020
F +44 191 518 0032

3 Furze Court
114 Wickham Road
Fareham, Hampshire
PO167SH, United Kingdom
T +44 132 984 8900
F +44 132 984 8901

Middle East & Africa

2 Monteer Road, Isando
Kempton Park, 1600
South Africa
T +27 11 974 3336
F +27 11 974 7005

PO Box 17033
Jebel Ali Free Zone
Dubai,
United Arab Emirates
T +971 4883 5235
F +971 4883 5312

Asia Pacific

19, Kian Teck Crescent,
Singapore 628885
T +65 6262 4515
F +65 6268 0028

9/F Gateway Building
No.10 Ya Bao Road
Chaoyang District
Beijing, P.R. China
T +86 10 5821 1188
F +86 10 5821 1100

No 15 Xing Wang Road
Wuqing Development Area
Tianjin 301700
P.R. China
T +86 22 8212 3300
F +86 22 8212 3308

Lot 13111, Mukim Labu,
Kawasan Perindustrian Nilai
71807 Nilai, Negeri Sembilan
Malaysia
T +60 6 799 2323
F +60 6 799 9942

471 Mountain Highway
Bayswater, Victoria 3153
Australia
T +61 3 9721 0200
F +61 3 9720 0588

301, Solitaire Corporate Park
151, M.V. Road, Andheri(E)
Mumbai-400093,
Maharashtra, India
T +91 22 6694 2711
F +91 22 2825 3394

NOF Shinagawa Konan Building
1-2-5, Higashi-shinagawa
Shinagawa-Ku, Tokyo
140-0002 Japan
T +81 3 5769 6873
F +81 3 5769 6902

© 2008 Emerson Process Management. All rights reserved.

The Emerson logo is a trademark and service mark of Emerson Electric Co. "Brand mark listing" are marks of one of the Emerson Process Management family of companies. All other marks are property of their respective owners.

The contents of this publication are presented for information purposes only, and while every effort has been made to ensure their accuracy, they are not to be construed as warranties or guarantees, express or implied, regarding the products or services described herein or their use or applicability. All sales are governed by our terms and conditions, which are available on request. We reserve the right to modify or improve the designs or specifications of our products at any time without notice.

The color orange, U.S. Reg. No. 2,739,393, is a registered trademark of the Bettis Corporation.

BETTIS

www.Bettis.com

EMERSON
Process Management