

## 1.0 Features and Description

The SmartStep Electric Actuator is an intelligent actuator designed for precise control of quarter turn valves and dampers. Using stepper motor technology, the SmartStep proportionally positions valves to 0.5 degrees for accurate flow control. The Actuator is a robust design that is well suited for 100% modulation and 100% duty cycle.

The operating parameters can be programmed to change the speed, acceleration curves, command response, and position profile. These are factory programmed via an onboard RS-485 serial port. The parameters can be modified to tailor the performance to the application. The Valve Flow profile is programmed into a table for the actual valve type that the actuator is mounted on. The flow profile can be used to accurately convert a “% flow” input command to valve position.

## 2.0 Technical Specifications and Overview

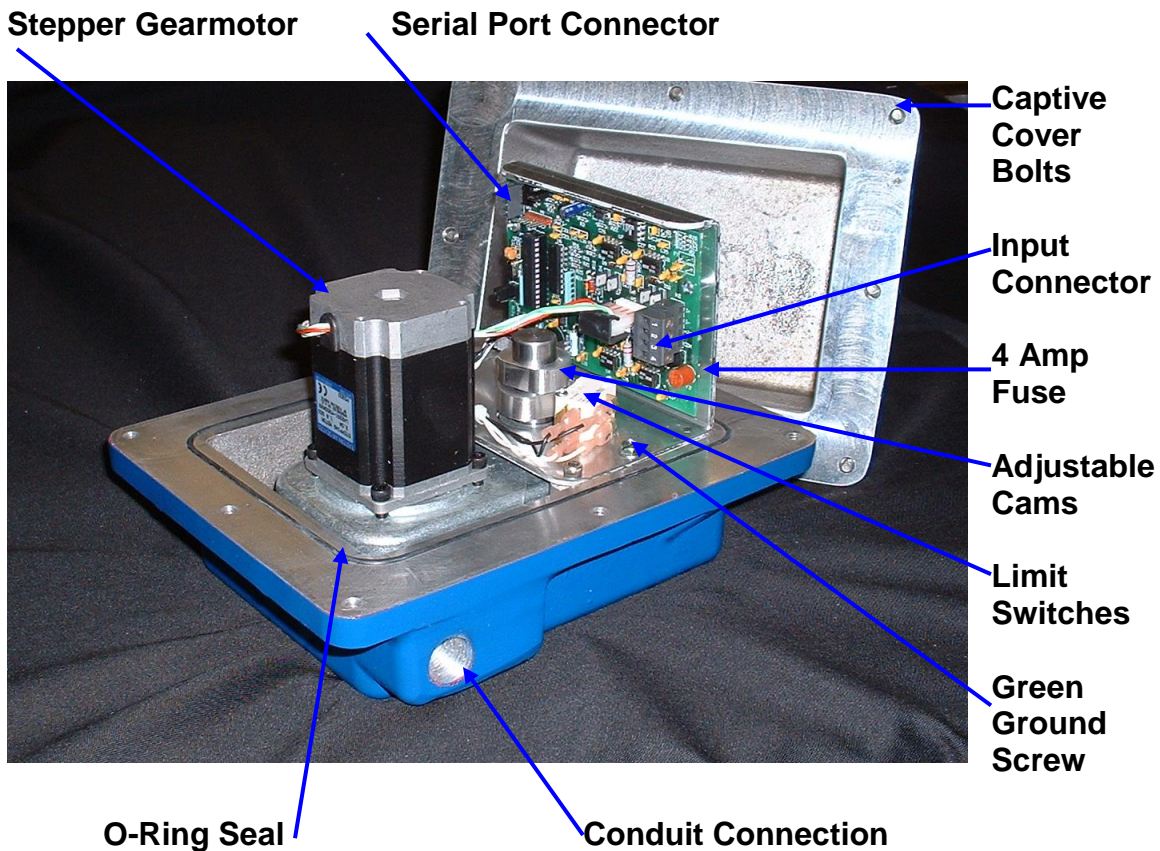

**CAUTION:** Maximum Voltage to be connected to the SmartStep is 24 VDC. As with all electrical equipment, use caution when SmartStep is energized when the cover is removed.

**2.1 INPUT:** Inputs are made to the H2 connector. The command signal is a differential input with approximately 66 ohms of input impedance. Up to 12 volts of common mode signal can be tolerated.

- #1 on Input Connector is the positive of the 4-20 mA Command Signal.
- #2 on Input Connector is the negative of the 4-20 mA Command Signal.
- #3 is positive 24 VDC from external power supply.
- #4 is common lead from power supply.

A green ground wire is attached to the green ground screw on the metal limit switch plate.

It is recommended that the 4-20 mA Command Signal cable be a twisted pair shielded cable. The power supply can be standard industrial grade wire. Make certain that all connections are securely made. The green ground wire needs to be securely tightened under the green ground screw on the SmartStep and to the machine chassis ground. The grounding is very important to maintain the best performance and to reduce electrical noise that is present in electrical systems.

- 2.2 Operating Torque: 350 inch-lbs. Holding Torque when SmartStep is powered up: 350 inch-lbs Minimum.
- 2.3 Speed for quarter turn can be factory programmed between 5 seconds to 30 seconds. For speeds outside this range, contact factory.
- 2.4 Operating Temperatures: -30 degree C to 75 degrees C. Please contact factory outside this temperature range.
- 2.5 Mounting of the SmartStep actuator can be in any orientation. Allow for 5 inches of clearance to remove the cover when mounting the actuator.
- 2.6 Designed for 100% duty cycle, 100% modulation, and in excess of 6000 motor starts per hour.
- 2.7 Conduit connection is ½ inch NPT Threaded.
- 2.8 UL/CUL Recognized component under File number E234855. The Cast Aluminum enclosure is a Type 4 rated enclosure.

2.9 Power Source required is 24VDC at 2 Amps. Power supply tolerance shall be +/- 10% or better.

2.10 SmartStep weight: 19 lbs.

### 3.0 Electronic Components

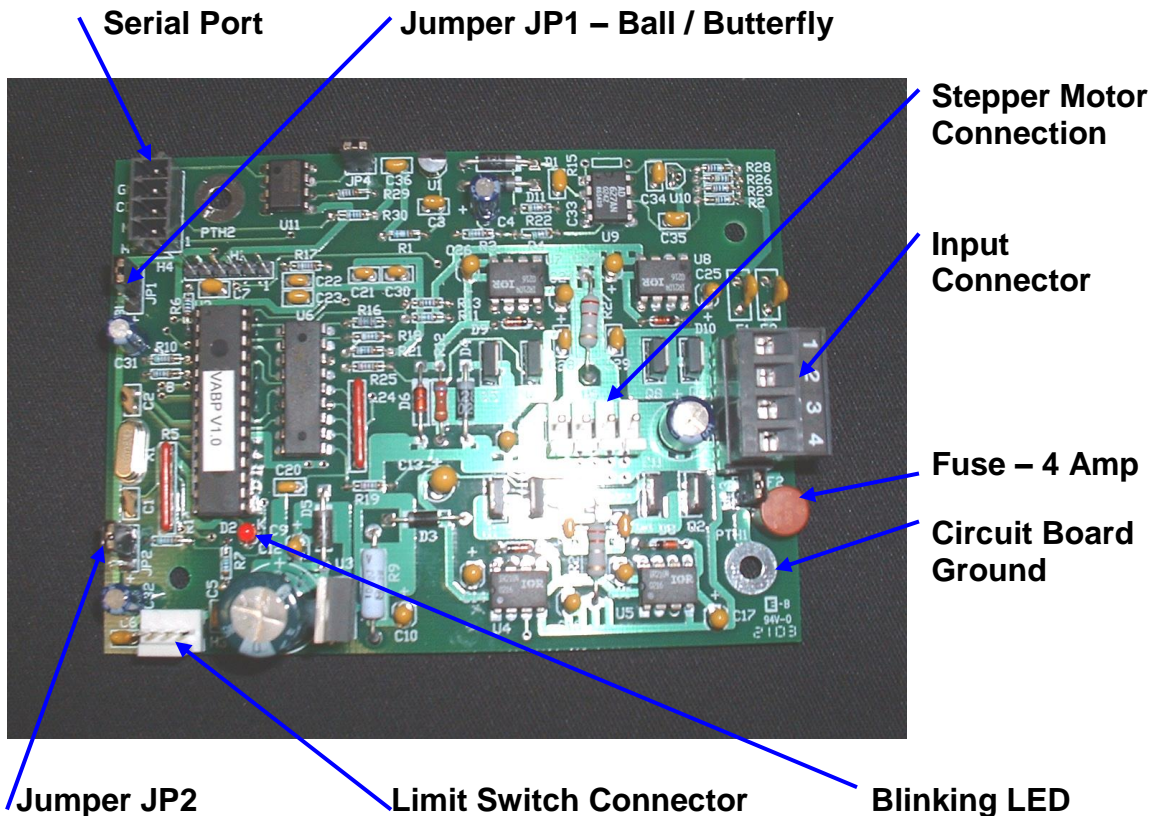

### 3.1 Jumpers

Four Jumpers exist on the actuator control. JP1 selects between butterfly valve configuration and ball valve configuration. JP1 in the upper position (BA silkscreen on circuit board) selects the ball valve configuration and JP1 in the lower position (BU) selects the butterfly. The valve flow profiles for each can be factory programmed.

JP2 selects between using both limit switches (ALS) or 90-degree operation. When JP2 is in the upper position (ALS), the SmartStep reads both limit switches wherever they are set up to 100 degrees of rotation. When JP2 is set in the lower position (90), only the Counter-Clockwise Limit Switch (CCWLS) is found at power-on. Rotation is set at a fixed 90 degrees of rotation from the Counter-Clockwise Limit Switch. For proper operation, both JP1 and JP2 must be

installed in one of the available positions and should not be permanently removed. Jumper JP3 is an internal circuit board grounding jumper and should not be removed in normal operation. Jumper JP4 is a termination jumper for the RS485 serial port. JP4 should also not be removed for normal operation.

In any case, when any jumper is moved to a new location, power to the SmartStep should be cycled to reset the software parameters in the control electronics.

### **3.2 Limit Switches**

In all cases, the Counter-Clockwise Limit Switch (CCWLS) is found after power is applied to the unit. Counter-Clockwise is defined as looking down the shaft at the limit switches from the top. The CCWLS is the lower limit switch closest to the metal plate and is actuated by the CCW lobe of the lower cam. The CCW lobe of the cam is the point where the roller falls into the cam cut-away during CCW rotation. During power start in the CCWLS searching, the control will rotate up to 135° CCW if the switch is initially in the cut-away or 315° if it's not.

If JP2 is in the ALS position (upper position), then after the CCWLS is found, the control searches for the CWLS (Clockwise Limit Switch) and records the amount of rotation necessary to reach it. The CWLS is the upper limit switch. The CWLS is actuated by the CW lobe of its corresponding cam. During CWLS searching, the control will rotate up to 100° CW from home searching for the CWLS.

If JP2 is in the "90" position (lower position), at power up the SmartStep will search for the Counter-Clockwise Limit Switch (CCWLS) only. Once the CCWLS is determined, the SmartStep will operate in the 90-degree range from the CCWLS. The Clockwise Limit Switch (CWLS) is not used in this setup.

### **3.3 Configuration**

Two complete configurations will be resident in the control's memory – one for ball valves (JP1 in upper position) and one for butterfly valves (JP1 in lower position). The parameters of each configuration can be modified by running PC-Valve on any Win32 computer with a RS-485 port. Adjustable parameters and their default values are shown in the following table.

In case of the loss of the 4-20 mA command signal, the SmartStep is factory programmed to one of three states: 1) Move to CCWLS (Home), 2) Move to CWLS (Away), or 3) Stay at last position.

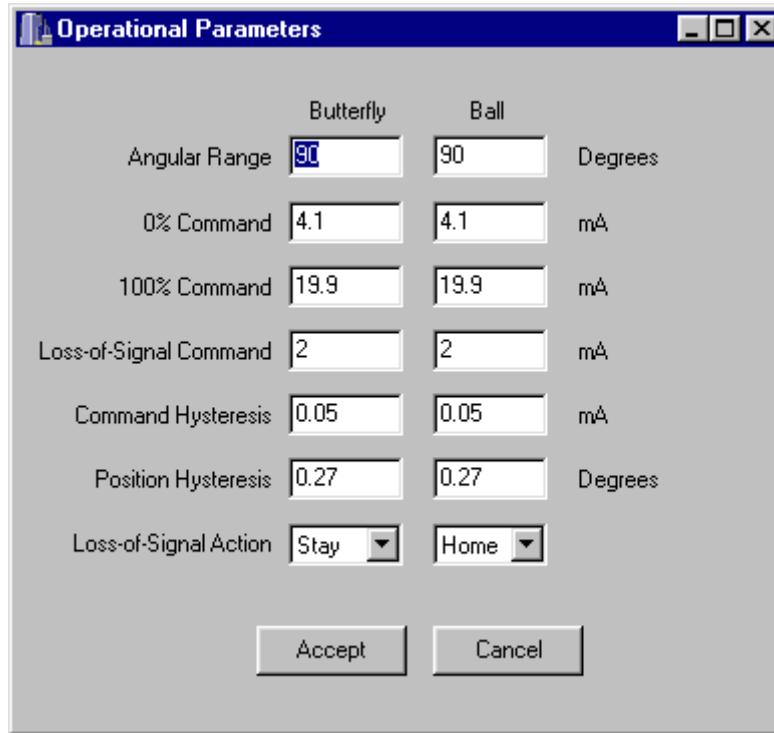

**3.5 Flow Look-Up Tables**

The following look-up tables are programmed as the defaults.

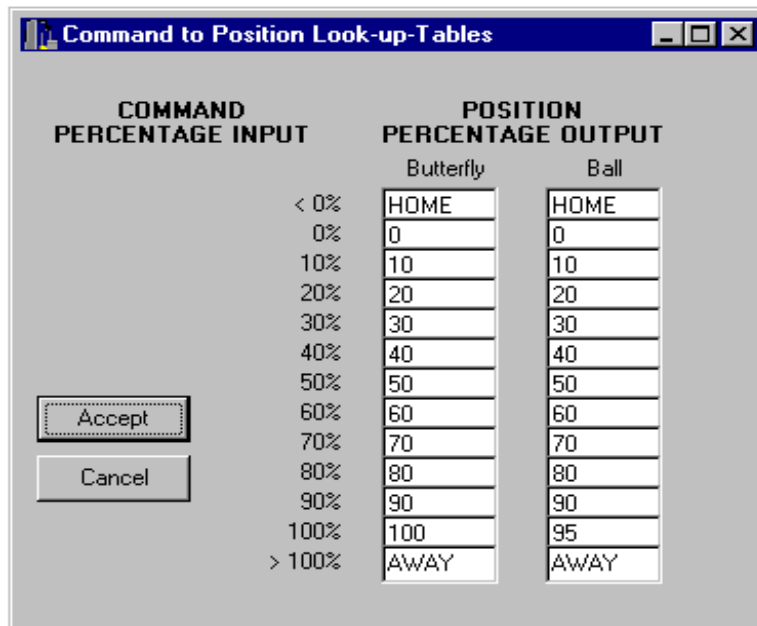

**3.6 Blink Codes on Electronic LED**

The electronic controller contains an LED used to report controller status. The following table defines status blink codes:

<b>Blink Code</b>	<b>Message</b>
0	Watchdog Timer Failed Self Test
1	Normal
2	Power Supply Voltage Low (less than 20.4 V.)
3	EEPROM Parameter Checksum Error (parameters will be restored to default values after power is cycled)
4	Counter-Clockwise Limit Switch Error
5	Clockwise Limit Switch Error

**3.7 Power Supply Requirements**

A 24VDC @ 2A power source will be required. Power supply tolerance shall be +/- 10% or better. The IDEC 50-Watt PS5R-D24 DIN rail mount power supply has been tested and this type of power supply is approved to power one SmartStep actuator. In any case, the SmartStep will not operate the motor if the power supply voltage falls below 20.4V.

**3.8 Power-Up Sequence**

Upon application of power to the unit, the control will “home” the valve to the CCW Limit Switch. This operation will also take place when power to the unit is temporarily interrupted for greater than 300ms. Power “brown-outs” are defined as supply voltages less than 20.4 volts but greater than 14.4 volts. Brown-outs can be tolerated indefinitely without the need to home the valve, however, valve operation will be inhibited while this condition persists.

**3.9 Control Electronics**

Five connectors are present on the controller. H1 is for In-Circuit Programming of the microcontroller. H2 is for the Input Connection of power and command signal. H2 includes a removable terminal block for ease of connection. H3 connects to the limit-switch wiring harness. H4 is the RS485 serial port. H5 is the Stepper Motor Connection. The following tables define the pins of each connector:

<b>H2 – Power/Command Signal Terminal Block</b>	
1	4-20mA command, positive side
2	4-20mA command, negative side
3	24V power, positive side
4	24V power, negative side

<b>H3 – Limit Switch Header</b>	
1	CWLS, N.O. terminal
2	CWLS, armature terminal
3	CCWLS, N.O. terminal
4	CCWLS, armature terminal

<b>H4 – RS-485 Port</b>	
4	GND
3	COM
2	M-
1	M+

The principle electrical components of the control include:

**Bipolar Stepper Motor** – Two-phase, four-wire motor with 4.7V 2A coils.

**Current Regulator** – L6506 regulates current in each motor phase at 2.0A running and 1.0A holding. By providing 24VDC to the current regulator, the motor current ramps up very quickly thereby maximizing running torque.

**Power H-Bridges** – Each of the two H-bridges are comprised of four IRFU024N N-channel power MOSFETs and two IR2104 smart half-bridge drivers. The smart half-bridge drivers provide shoot-through lockout, under-voltage protection, and power-up protection. These H-Bridges can reverse the motor phase polarity in under 1us.

**Microcontroller** – The microcontroller generates the stepping sequences provided to the half-bridge drivers.

**Circuitry Protection** – The 24VDC input is protected with a 4A replaceable sub-miniature fuse. The 4-20mA input is protected with two 100mA resettable fuses. Both inputs also have Transient Voltage Suppression devices.

#### **4.0 Setting up the Limit Switches**

Remove the SmartStep cover first. Use caution, as electric power will be connected when setting up the Limit Switch cams.

The lower limit switch is considered the Counter-Clockwise Limit Switch (CCWLS), which is reached when the command signal reaches 4 mA. To adjust the counter-clockwise limit, send a 4 mA signal to the SmartStep. If the output shaft is needed to turn an additional amount counter-clockwise, loosen the lower switch cam with an Allen wrench and rotate clockwise the necessary rotation. Change the command signal to 20 mA then back to 4 mA to check to for proper limit switch set up. A 4-20 mA loop calibrator is a very helpful tool in setting up the limit switches.

The upper limit switch is the Clockwise Limit Switch (CWLS), which is reached when the command signal reaches 20 mA. The same procedure is used in setting the clockwise limit switch as the counter-clockwise limit. Once both limit switches are set correctly, make certain that both switch cams are tightened securely.



5.0 Installation Dimensions.

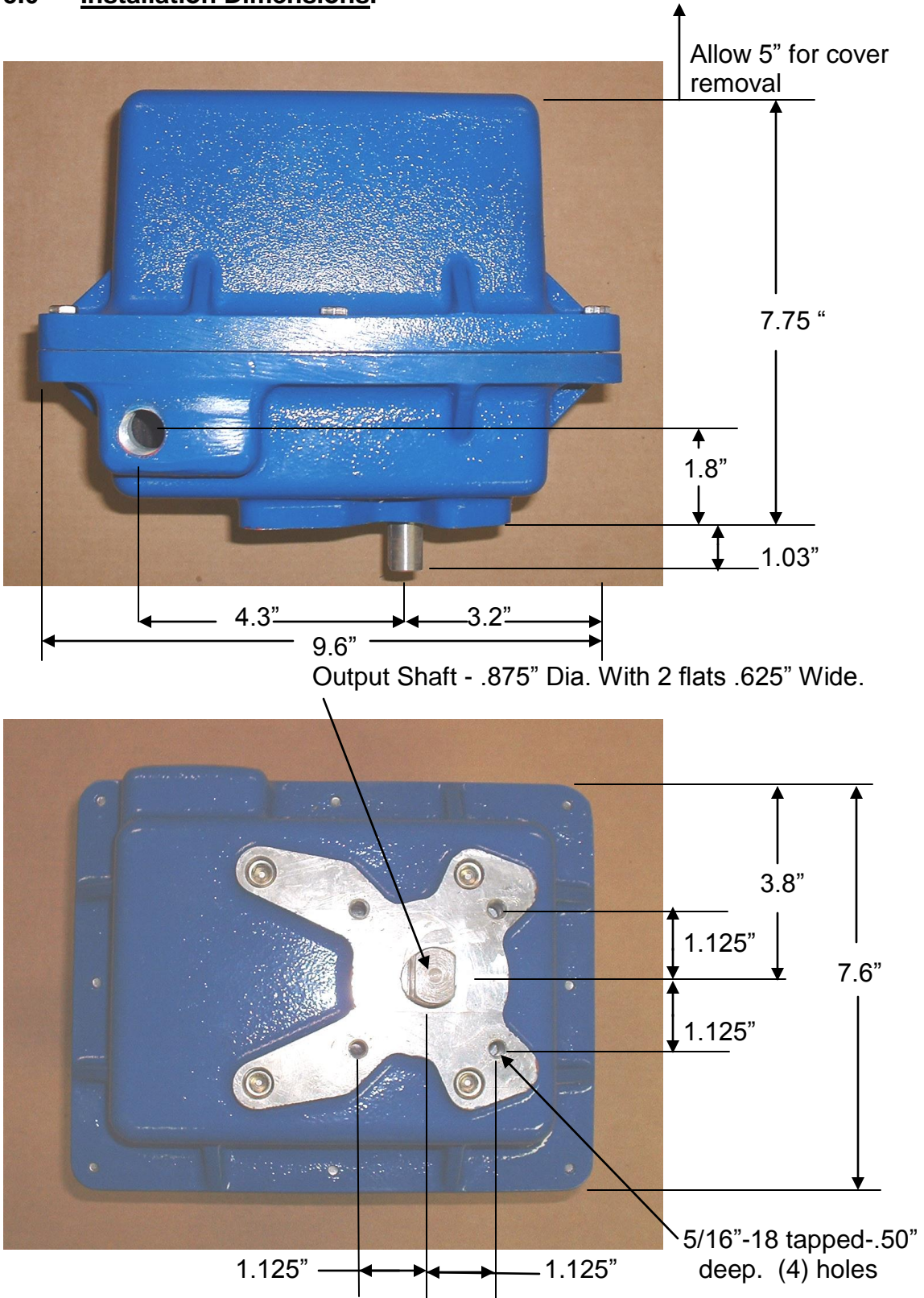

## **6.0 Maintenance**

Normal Maintenance is not required for the SmartStep. The gear train and bearings are totally enclosed and do not require lubrication. However, Annual Preventative Maintenance will help to prevent any problems. The following items should be evaluated:

- 6.1 Excessive moisture should not be present inside the SmartStep enclosure. This can lead to electrical or mechanical problems.
- 6.2 Mis-alignment of the load coupling to the output shaft can cause excessive side loading which can reduce the life of the SmartStep.
- 6.3 Insure that all wiring and ground wires are in good condition and tight clean connections are made. This is one of the leading causes of performance problems with the actuator.
- 6.4 The SmartStep should be kept clean inside the enclosure free of outside chemicals. This is best accomplished by keeping tight conduit connections and making certain that the enclosure cover is securely bolted to the SmartStep base.

## **7.0 Storage of SmartStep Actuator**

The SmartStep should be stored in a clean dry environment free of corrosive chemicals. The environment should not have excessive condensation or steam. If the SmartStep is below –30 degrees C, then it will need to be warmed above – 30 degrees C before it is considered operational.

## **8.0 Troubleshooting**

- 8.1 The most likely cause of problems is incorrect wiring connections. Measure that the input voltage is 24 VDC. Measure that the command signal is between 4 to 20 mA. Ensure that the Smart Step is solidly grounded via a grounding wire to the green ground screw.
- 8.2 Check for the blinking LED on the circuit board. Normal operation is approximately one blink per second. If the LED is dark, then 1) There is not proper voltage connected to the correct #3 and #4 inputs, or 2) There is a problem in the Microprocessor control. Cycle the power off, and then on to reset the normal operation of the Microprocessor. If the LED is still dark and the correct 24 VDC is properly connected, please contact factory.

- 8.3 If the LED is blinking twice between pauses, then the power supply voltage is below 20.4 volts DC and the SmartStep will not operate until the voltage is corrected to above 20.4 volts DC.
- 8.4 Blink code 3 on the LED indicates that the programmable parameters are incorrect. Check that all Jumpers are in place on the circuit board and that none of the Jumpers are completely removed. Cycling the power supply off, and then on will correct this condition.
- 8.5 Blink code 4 is a Counter-Clockwise Limit Switch Error which is the lower limit switch mounted on the metal plate. Blink code 5 is a Clockwise Limit Switch Error, which is the upper limit switch. If you receive either of these errors, check to make certain that the limit switch cams are correctly set up. Check the wiring and terminals on the wiring harness to the limit switches to make certain that they are securely fastened. Then cycle the power supply to reset the system.
- 8.6 If the SmartStep is operating incorrectly or is continuously hunting for the correct position, there could be electrical noise on the 4-20 mA command signal. Check that the green ground wire is securely fastened to the ground screw on the Smart Step and to the ground of the controller. Check that the circuit board mounting screws are tightened. The 4-20 mA command signal should be in a shielded twisted pair wire with the shield grounded on both ends.
- 8.7 If the SmartStep motor is making a high-pitched sound yet there is no rotation, the required torque may be over the SmartStep limit causing the motor to electrically slip. Check the valve and coupling for binding, obstructions, or anything that would increase the torque required from the SmartStep. Check that the maximum required torque is less than the torque that the SmartStep is rated for as required torques for valves can vary significantly from their nameplates. It may require torque testing on the valve to determine the actual torque required. If the problem continues, remove the SmartStep from the load and retest. If it operates correctly unloaded, then recheck the valve and coupling for binding.