

DEMCO Butterfly Valves

Quality design and rugged dependability in meeting the rigorous requirements of industrial, oilfield and drilling applications

TECHNOLOGY



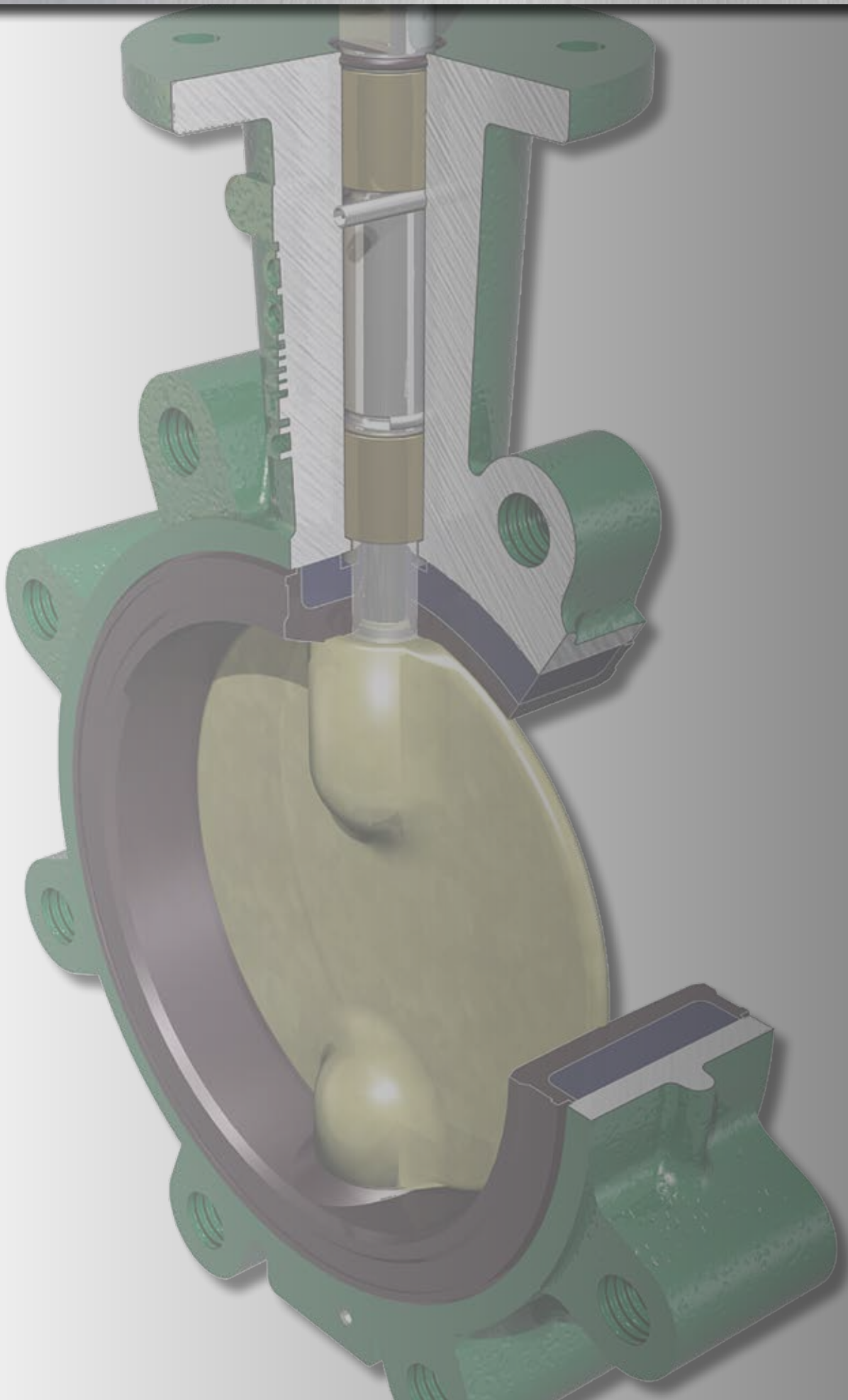

Table of Contents

DEMCO BUTTERFLY VALVES

Introduction.....	2
Features and Benefits	3
Styles and Accessories.....	6
Series NE-C, NE-I, NE-D, NEI-T	9
Series NF-C	10
Base Part Numbers and Weights	12
Marine Series.....	13
Component Parts List.....	14
Dimensional Data (Valves)	16
Handles	22
Worm Gear Operators	23
Stem Extensions.....	25
General Technical Information.....	26
Torque Data	31
Standard Material Data	32
Material Selection Guide.....	33
Services for Valves and Actuation.....	39
Trademark Information	40

DEMCO Butterfly Valves



Oklahoma City,
Okla., USA

Cameron is a leading provider of valves, valve automation, and measurement systems to the oil and gas industry. Our products are primarily used to control, direct and measure the flow of oil and gas as it is moved to refineries, petrochemical plants, and industrial centers for processing.

We provide valve products that are sold through distributor networks worldwide for use in both oil and gas and industrial applications and include such widely recognized brands as DEMCO®, NAVCO®, NEWCO®, NUTRON®, THORNHILL CRAVER®, TECHNO™, TOM WHEATLEY®, WHEATLEY®, and WKM®.

Cameron's DEMCO butterfly valves are the valves of choice, engineered and proven for drilling and production industries. Designed for dependable, heavy-duty performance in abrasive and corrosive service conditions, DEMCO butterfly valves are commonly selected for a number of oilfield applications.

FEATURES AND BENEFITS

As one of the most durable resilient-seated butterfly valves in the industry, Cameron's DEMCO butterfly valve excels in a variety of applications.

Cast in both wafer and tapped lug patterns in a variety of material choices, DEMCO butterfly valves feature a one-piece body for reduced weight and increased strength.

The unique stem hole design in the disc ensures the dry stem journal, and the hard-backed seat allows ease of installation, reliable operation and in-field repairability without special tools. DEMCO butterfly valves are available in sizes 2" to 36" (50 mm to 900 mm).

Engineered for long-term, reduced-maintenance performance, DEMCO butterfly valves are commonly selected for a variety of applications in the following industries:

- Chemical and petrochemical
- Agriculture
- Oil and gas drilling and production
- Food and beverage
- Water and waste water
- Cooling towers (HVAC)
- Power
- Mining and materials
- Dry bulk handling
- Marine and government

Bi-Directional Sealing

Cameron's DEMCO butterfly valve provides bi-directional sealing at full-rated pressure with identical flow from either direction.

Integral Flange Seal

An integral flange seal molded into the edge of the seat accommodates ASME weld neck, slip-on, threaded, socket and stub end type C flanges.

ASME Class 150 Rating

With a body rating of ASME Class 150 (285 psi non-shock), the wafer body diameters are designed to self-center in the ASME Class 150 flange pattern.

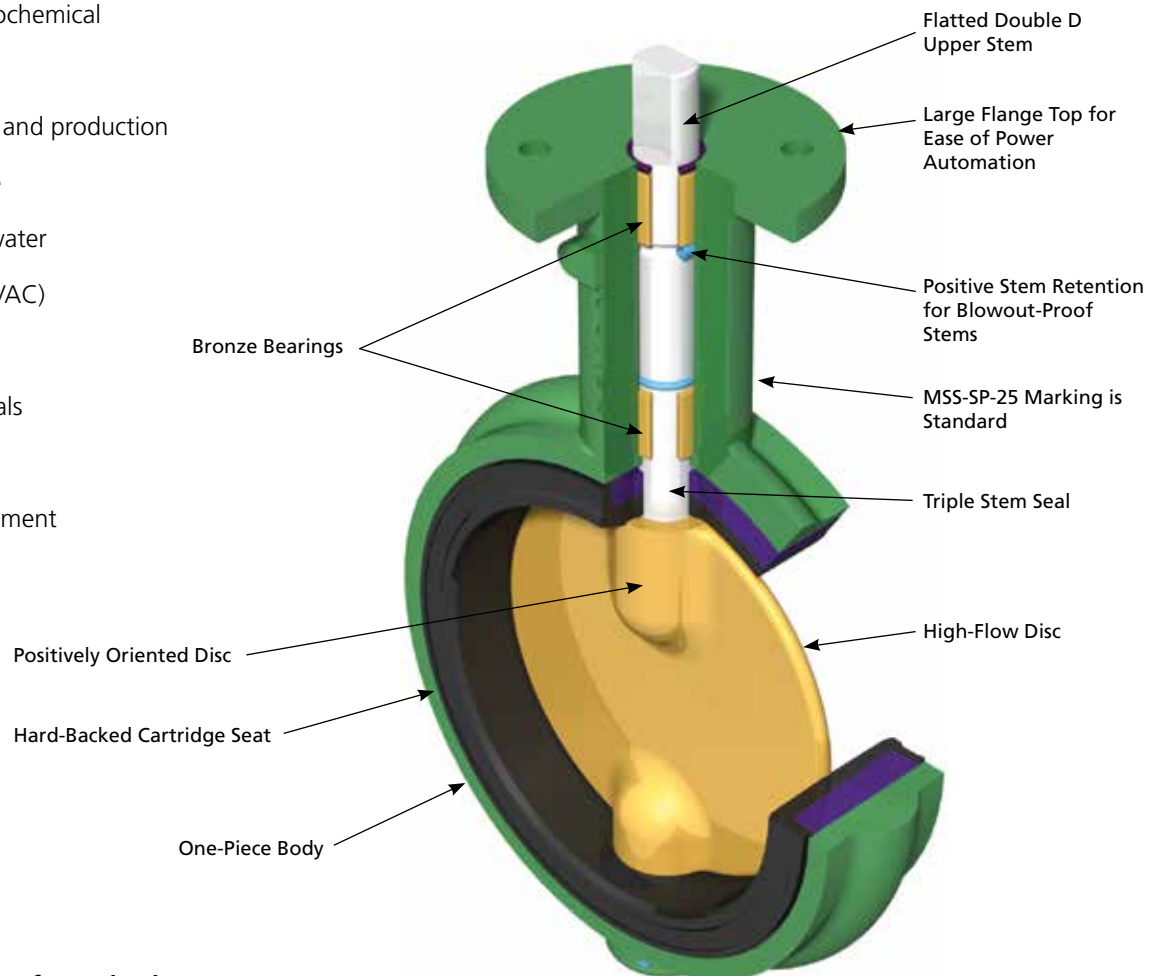

Wafer Style Shown

FEATURES AND BENEFITS (CONT.)

Multiple Pressure Ratings

Three drop-tight pressure ratings are offered for 2" to 12" (50 mm to 300 mm) sizes. The standard shut-off pressure rating is 200 psi, but 285 and 50 psi shut-off ratings are also available. A throttling 0 psi-rated valve is available where drop-tight closure is not required and minimal torque is desired. Both the 50 psi and throttling ratings allow for smaller actuators, which can significantly reduce overall installation cost in automated applications. The 14" to 36" (350 mm to 900 mm) size valves are available in 150 and 50 psi drop-tight shut-off ratings, as well as throttling.

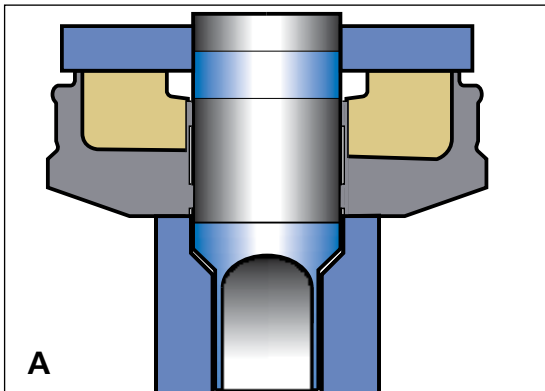

A. Dry Stem Journal Reduces Potential for Leakage

The DEMCO valve's disc is uniquely designed with a continuous annular-raised band around the stem hole and disc edge, which presses into the seat flat at every angular position.

The resilient seat presses back with a higher force than the line pressure, preventing leakage to the stem. In addition, two O-ring ribs are provided in the seat stem bore, creating a triple stem seal. In competitive stem seal designs with boot seats, a seal is accomplished by an interference squeezing on the stem or an O-ring in the stem journal. The potential for leakage behind the seat is high for this competitive design. As the disc wipes the seat, elongation of the stem seal area allows leakage to collect behind the seat. This condition is reduced by the DEMCO valve's dry stem journal and hard-backed seat.

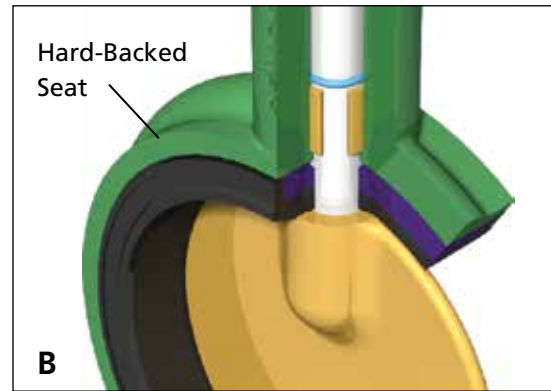

B. Hard-Backed Cartridge Seat

The DEMCO valve's cartridge seat is constructed by permanently bonding a resilient elastomer to a rigid backing ring. In addition to superior sealing integrity, this design:

- Makes valve installation easier because no special precautions are required for disc position. This is especially advantageous when installing valves with fail-closed actuators.
- Reduces high torque and premature failure caused by elastomer distortion, as found in other non-rigid seat designs.
- Simplifies seat replacement because the seat is slip-fitted into the body with no need for special tools.

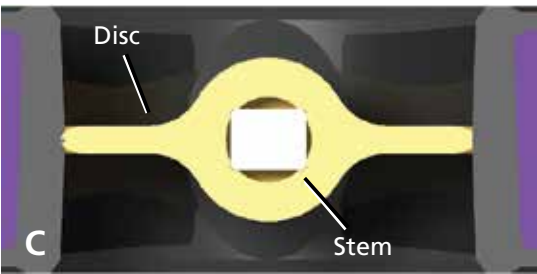

C. Positively Oriented Disc

The rectangular drive ensures the proper orientation of the stem disc connection. In 2" to 24" (50 mm to 600 mm) size valves, the disc is permitted to float on the stem to center in the valve seat. This design enhances drop-tight sealing and prolongs service life.

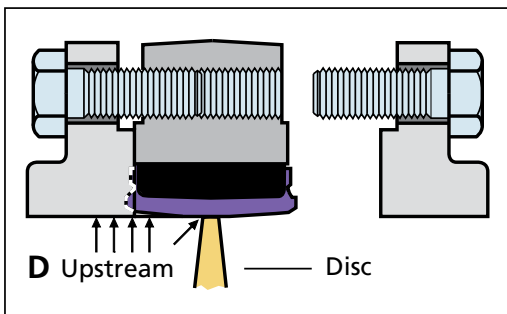

D. End-of-Line Service

Lug body valves may be used in end-of-line service with downstream piping removed. Only weld-neck or socket flanges can be used for this service. Since upstream pressure is excluded between the flange and the seat face by the DEMCO flange seal design, there is no effective force to slide the seat downstream. DEMCO 2" to 12" (50 mm to 300 mm) lug butterfly valves are suitable for liquid service up to 200 psi with downstream piping removed at 150 psi for 14" to 36" (350 mm to 900 mm) valves.

Lug body valves are recommended for isolation of pumps, control devices or other system components, which may need to be removed for repair or replacement. Lug valves also are suitable for installation at points from which piping expansion may proceed. Such valves normally are blanked with blind flanges to protect the exposed seats until new piping is attached.

SPECIFICATIONS

Sizes

2" to 36" (50 mm to 900 mm)

Body Type and Style Designations

Long-Neck NE-C and NF-C: 2" to 36" (50 mm to 900 mm) wafer/lug, 36" (900 mm)

Short-Neck NE-I and NE-I Sanitary: 2" to 12" (50 mm to 300 mm) wafer/lug

NE-IT Teflon: 2" to 10" (50 mm to 250 mm) wafer/lug

NE-D: 2" to 12" (50 mm to 300 mm) wafer

Marine: 2" to 24" (50 mm to 600 mm) wafer/lug

Pressure Rating

2" to 12" (50 mm to 300 mm):
0 (throttling); 50, 200 and 285 psi

NEI-T: 2" to 10" (50 mm to 250 mm): 150 psi
14" to 36" (350 mm to 900 mm): 0, 50 and 150 psi

Operating Temperatures

-30° F to 300° F (-34° C to 204° C), depending on seat material selection and application (see page 32)

Standard Material Options

Bodies: Iron, steel, stainless steel and bronze

Discs: Nickel-plated ductile iron, bronze and stainless steel

Stems: 416 and 316 stainless steel

Seats: Buna-N, EPDM, FKM and Neoprene

*Many more options available (consult Cameron or see pages 9, 10 and 11 on how to order).

STYLES AND ACCESSORIES

The DEMCO butterfly valve comes in a variety of styles to suit a range of applications. In addition, a variety of quality accessories are available to further enhance its suitability to the application.

Series NE-C

Sizes 2" to 12" (50 mm to 300 mm) are available in both wafer and lug styles. This series is a general purpose valve with a neck length designed to provide full clearance for the valve top over 2" of insulation on ASME Class 150 pipe flanges.



Series NE-I

Sizes 2" to 12" (50 mm to 300 mm) are suited for a range of applications in many industries, including food and beverage utilities and process flowlines. This short neck design is offered in a variety of body materials. The valves are designed for installation between ASME Class 125 and 150 flanges.



Series NE-D

The valves in this series can be made in sizes 2" to 12" (50 mm to 300 mm). The Series NE-D valve is a short-neck valve with body notches to fit popular, lightweight flange patterns, making it ideal for both the bulk material handling and the transportation industries. Valves also will center in ASME Class 125 and 150 flanges.



Series NF-C

Sizes 14" to 36" (350 mm to 900 mm) are available in both wafer and lug styles. The wafer body has two drilled locator lugs at the top and bottom for ASME Class 150 flanges. Bronze bearings are installed on both stems for reduced operating torque.



Series NE-I Sanitary

This series comes in sizes 2" to 12" (50 mm to 300 mm). It is similar to the Series NE-I valve, but is exclusively designed to meet the rigorous requirements of sanitary service in the food and beverage industry. The body is available in bronze, stainless steel, aluminum or electroless nickel-coated ductile iron.

FDA-approved materials are used for all wetted parts. Handle parts are bronze and stainless steel, permitting caustic washdown.

Other benefits:

- The DEMCO dry journal stem seal system ensures sanitary butterfly valve construction.
- Drilled passageways, a design originated by the DEMCO brand, vent the entire interior of the disc. No closed chamber is provided for the culture of undesirable organisms.
- Discs are produced from smooth and non-porous investment castings. Stem bosses are reduced for increased flow.
- The mating flange contacts and compresses the projecting inner surface of the resilient seat to form a smooth and uninterrupted flow way. This positive seal between the innermost contact of the seat and flange ensures aseptic conditions after a piping flush.

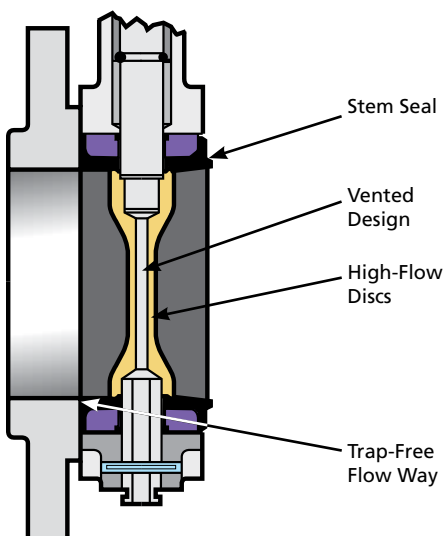

Sanitary Features

Series NEI-T Teflon

Because of the inert, aseptic, non-stick character of Teflon®, the DEMCO NEI-T Teflon-lined butterfly valve is ideal for clean lines in food and beverage plants. The Teflon seat consists of a virgin Teflon liner overlaid and bonded to an elastomer EPDM cushion, which provides resilience for sealing. The Teflon liner extends over the seat faces, completely covering and sealing the resilient material from contact with line fluids.

Marine

DEMCO marine butterfly valves are available in the NE-C lug, NE-I lug and wafer, and NE-D wafer styles, and conform to:

- Title 46 of the Code of Federal Regulations
- Part 56 of the US Coast Guard's Marine Engineering Regulations
- The American Bureau of Shipping Standard, including tagging per MSS-SP-25 and testing per MSS-SP-67

STYLES AND ACCESSORIES (CONT.)

A. Actuators

Consult Cameron or visit www.c-a-m.com/valveautomation for actuation options.



A. DEMCO NE-C Wafer

B. Handles and Stem Extensions

There are three basic handle designs that are compatible with any 2" to 12" (50 mm to 300 mm) valve: ten-position locking, two-position locking and memory stop. Memory-stop handles provide throttling, which is infinitely adjustable and can be set by a lock nut with a memory-stop setting (adjustable open stop). Handles are available in basic trim, corrosion-resistant trim and sanitary trim. Stem extensions are fabricated from carbon steel parts and contained in a tubular housing. Gaskets and O-rings seal the stem extension at the top and bottom. These extensions are fabricated to specified lengths.



B. Stem Extension with Handle on Series NE-I Butterfly Valve

C. Gear Operators

DEMCO weatherproof gear operators are offered with a choice of handwheel, chainwheel or square nuts. The worm gear has either self-locking set screws to control open and closed positioning or an optional adjustable memory-stop for balance return to a preset open position after closing.

C. Gear-Operated

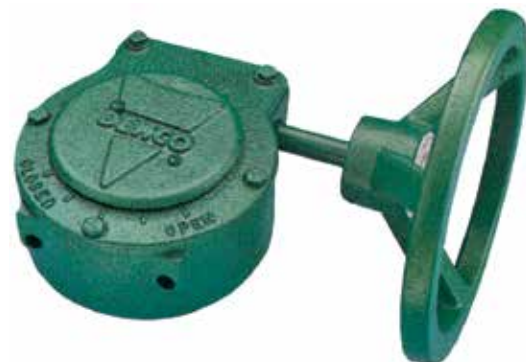

SERIES NE-C, NE-I, NE-D, NEI-T

2" to 12" (50 mm to 300 mm)

Key No.	Qty.	Description	Material
1	1	Body	*
2	1	Seat	*
3	1	Disc	*
4	1	Upper Stem	*
6	1	Lower Stem	*
7	2	Spring Pin	Stainless Steel
14	1	Retainer	Stainless Steel
22	1	Top O-ring	Buna-N
23	•	Stem O-ring	Buna-N
24	2	Bearing	Bronze

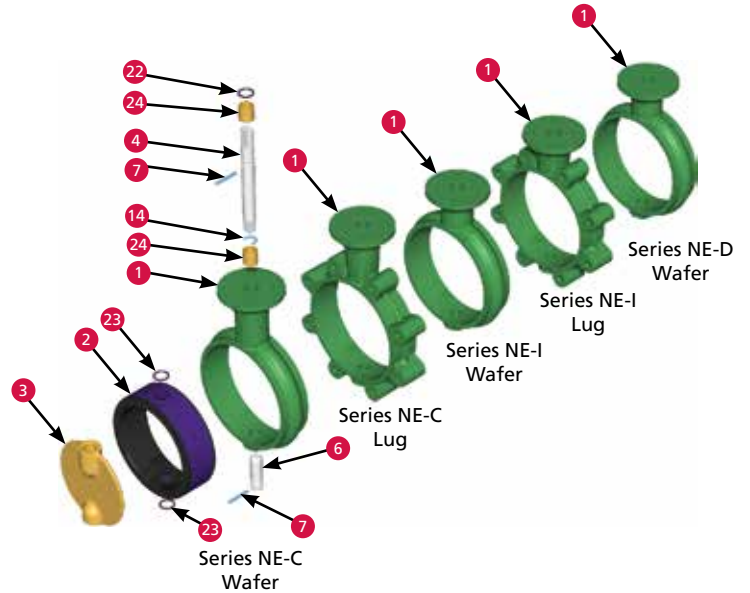

- * See How to Order for material choices/styles. Complete material specs on page 32.
- Four required for throttling valves only.

HOW TO ORDER

XXXXX Base Part Number	X Body Configuration	X Body Material*	X Stem Material	X Disc Material	XX Seat Elastomer	X Actuation																																																																																								
<table border="1"> <tr><td>NE-C/NE-I/NEI-T</td></tr> <tr><td>Wafer 1</td></tr> <tr><td>Lug 5</td></tr> <tr><td>NE-D</td></tr> <tr><td>Wafer 1</td></tr> </table>	NE-C/NE-I/NEI-T	Wafer 1	Lug 5	NE-D	Wafer 1	<table border="1"> <tr><td>NE-C (Long-Neck)</td></tr> <tr><td>Ductile Iron (Lug) 1</td></tr> <tr><td>Cast Iron (Wafer) 2</td></tr> <tr><td>NE-I and NE-I Sanitary</td></tr> <tr><td>Ductile Iron (NE-I, Wafer Only) 1</td></tr> <tr><td>Aluminum Bronze 3</td></tr> <tr><td>Carbon Steel (NE-I Only) 4</td></tr> <tr><td>Aluminum (NE-I, Wafer Only) 5</td></tr> <tr><td>ENC-Coated Ductile Iron 6</td></tr> <tr><td>Stainless Steel 8</td></tr> <tr><td>NE-D</td></tr> <tr><td>Ductile Iron 1</td></tr> <tr><td>NEI-T</td></tr> <tr><td>Ductile Iron 1</td></tr> <tr><td>Wafer – Short-Neck 1</td></tr> <tr><td>Lug – Long-Neck 1</td></tr> <tr><td>Gray Iron (Long-Neck Wafer) 2</td></tr> <tr><td>Aluminum Bronze 3</td></tr> <tr><td>Carbon Steel 4</td></tr> <tr><td>Aluminum (Wafer Only) 5</td></tr> <tr><td>Stainless Steel 8</td></tr> </table>	NE-C (Long-Neck)	Ductile Iron (Lug) 1	Cast Iron (Wafer) 2	NE-I and NE-I Sanitary	Ductile Iron (NE-I, Wafer Only) 1	Aluminum Bronze 3	Carbon Steel (NE-I Only) 4	Aluminum (NE-I, Wafer Only) 5	ENC-Coated Ductile Iron 6	Stainless Steel 8	NE-D	Ductile Iron 1	NEI-T	Ductile Iron 1	Wafer – Short-Neck 1	Lug – Long-Neck 1	Gray Iron (Long-Neck Wafer) 2	Aluminum Bronze 3	Carbon Steel 4	Aluminum (Wafer Only) 5	Stainless Steel 8	<table border="1"> <tr><td>NE-C, NE-I and NE-D</td></tr> <tr><td>416 SS 1</td></tr> <tr><td>Monel⁶ 3</td></tr> <tr><td>NEI-T</td></tr> <tr><td>316 SS 2</td></tr> <tr><td>Vented^{***} 2</td></tr> <tr><td>316 SS Solid^{***} 9</td></tr> <tr><td>NEI-Sanitary</td></tr> <tr><td>316 SS^{***} 2</td></tr> </table>	NE-C, NE-I and NE-D	416 SS 1	Monel ⁶ 3	NEI-T	316 SS 2	Vented ^{***} 2	316 SS Solid ^{***} 9	NEI-Sanitary	316 SS ^{***} 2	<table border="1"> <tr><td>NE-C, NE-I and NE-D</td></tr> <tr><td>316 SS 2</td></tr> <tr><td>Monel⁶ 3</td></tr> <tr><td>Aluminum 4</td></tr> <tr><td>Bronze 4</td></tr> <tr><td>Ductile Iron, Nickel-Plated 5</td></tr> <tr><td>PVF-Coated Ductile Iron¹ 6</td></tr> <tr><td>Alloy 20² 7</td></tr> <tr><td>Hastelloy "C"⁶ 8</td></tr> <tr><td>NEI-T and NE-I Sanitary</td></tr> <tr><td>316 SS Polished³ 2</td></tr> <tr><td>316 SS Tumbled³ 5</td></tr> <tr><td>Alloy 20 (NEI-T Only) 7</td></tr> <tr><td>Hastelloy "C"⁶ (NEI-T Only) 8</td></tr> <tr><td>316 SS Unpolished³ 9</td></tr> </table>	NE-C, NE-I and NE-D	316 SS 2	Monel ⁶ 3	Aluminum 4	Bronze 4	Ductile Iron, Nickel-Plated 5	PVF-Coated Ductile Iron ¹ 6	Alloy 20 ² 7	Hastelloy "C" ⁶ 8	NEI-T and NE-I Sanitary	316 SS Polished ³ 2	316 SS Tumbled ³ 5	Alloy 20 (NEI-T Only) 7	Hastelloy "C" ⁶ (NEI-T Only) 8	316 SS Unpolished ³ 9	<table border="1"> <tr><td>NE-C, NE-I and NE-D⁷</td></tr> <tr><td>Buna-N 31</td></tr> <tr><td>Black Neoprene 32</td></tr> <tr><td>Hypalon⁶ 33</td></tr> <tr><td>FKM 34</td></tr> <tr><td>Peroxide-Cured, EPDM 35</td></tr> <tr><td>Natural Rubber 36</td></tr> <tr><td>White Neoprene 37</td></tr> <tr><td>ETM-30230 01</td></tr> <tr><td>Fluorosteam 02</td></tr> <tr><td>Peroxide-Cured Food Grade, EPDM 03</td></tr> <tr><td>Peroxide-Cured, Buna-N 04</td></tr> <tr><td>Sulfur-Cured, EPDM/Teflon⁶ 05</td></tr> <tr><td>Food Grade, EPDM 05</td></tr> <tr><td>NEI-T</td></tr> <tr><td>Peroxide-Cured, EPDM/Teflon⁶ 35</td></tr> <tr><td>Sulfur-Cured, EPDM/Teflon⁶ 05</td></tr> <tr><td>NE-I Sanitary All Seats Food Grade</td></tr> <tr><td>Black Neoprene 32</td></tr> <tr><td>FKM 34</td></tr> <tr><td>EPDM 35</td></tr> <tr><td>White Neoprene 37</td></tr> <tr><td>Sulfur-Cured, EPDM 05</td></tr> </table>	NE-C, NE-I and NE-D⁷	Buna-N 31	Black Neoprene 32	Hypalon ⁶ 33	FKM 34	Peroxide-Cured, EPDM 35	Natural Rubber 36	White Neoprene 37	ETM-30230 01	Fluorosteam 02	Peroxide-Cured Food Grade, EPDM 03	Peroxide-Cured, Buna-N 04	Sulfur-Cured, EPDM/Teflon ⁶ 05	Food Grade, EPDM 05	NEI-T	Peroxide-Cured, EPDM/Teflon ⁶ 35	Sulfur-Cured, EPDM/Teflon ⁶ 05	NE-I Sanitary All Seats Food Grade	Black Neoprene 32	FKM 34	EPDM 35	White Neoprene 37	Sulfur-Cured, EPDM 05	<table border="1"> <tr><td>Handle</td></tr> <tr><td>10 Position Lkg. 1⁴</td></tr> <tr><td>Throttling Mem./ Stop 2⁴</td></tr> <tr><td>Square Nut 5</td></tr> <tr><td>2-Position Lkg. 6⁴</td></tr> <tr><td>10-Position Sanitary (NEI-T Only) 8</td></tr> <tr><td>None 9</td></tr> <tr><td>10-Position Lkg. Corrosion-Resistant K</td></tr> <tr><td>2-Position Lkg. Corrosion-Resistant L</td></tr> <tr><td>Throttling Mem./ Stop Corrosion-Resistant M</td></tr> <tr><td>Gear Operators⁵</td></tr> <tr><td>Handwheel A</td></tr> <tr><td>Crank 2" to 12" (50 mm to 300 mm) B</td></tr> <tr><td>Chainwheel C</td></tr> <tr><td>Square Nut D</td></tr> <tr><td>Bare Shaft E</td></tr> </table>	Handle	10 Position Lkg. 1 ⁴	Throttling Mem./ Stop 2 ⁴	Square Nut 5	2-Position Lkg. 6 ⁴	10-Position Sanitary (NEI-T Only) 8	None 9	10-Position Lkg. Corrosion-Resistant K	2-Position Lkg. Corrosion-Resistant L	Throttling Mem./ Stop Corrosion-Resistant M	Gear Operators⁵	Handwheel A	Crank 2" to 12" (50 mm to 300 mm) B	Chainwheel C	Square Nut D	Bare Shaft E
NE-C/NE-I/NEI-T																																																																																														
Wafer 1																																																																																														
Lug 5																																																																																														
NE-D																																																																																														
Wafer 1																																																																																														
NE-C (Long-Neck)																																																																																														
Ductile Iron (Lug) 1																																																																																														
Cast Iron (Wafer) 2																																																																																														
NE-I and NE-I Sanitary																																																																																														
Ductile Iron (NE-I, Wafer Only) 1																																																																																														
Aluminum Bronze 3																																																																																														
Carbon Steel (NE-I Only) 4																																																																																														
Aluminum (NE-I, Wafer Only) 5																																																																																														
ENC-Coated Ductile Iron 6																																																																																														
Stainless Steel 8																																																																																														
NE-D																																																																																														
Ductile Iron 1																																																																																														
NEI-T																																																																																														
Ductile Iron 1																																																																																														
Wafer – Short-Neck 1																																																																																														
Lug – Long-Neck 1																																																																																														
Gray Iron (Long-Neck Wafer) 2																																																																																														
Aluminum Bronze 3																																																																																														
Carbon Steel 4																																																																																														
Aluminum (Wafer Only) 5																																																																																														
Stainless Steel 8																																																																																														
NE-C, NE-I and NE-D																																																																																														
416 SS 1																																																																																														
Monel ⁶ 3																																																																																														
NEI-T																																																																																														
316 SS 2																																																																																														
Vented ^{***} 2																																																																																														
316 SS Solid ^{***} 9																																																																																														
NEI-Sanitary																																																																																														
316 SS ^{***} 2																																																																																														
NE-C, NE-I and NE-D																																																																																														
316 SS 2																																																																																														
Monel ⁶ 3																																																																																														
Aluminum 4																																																																																														
Bronze 4																																																																																														
Ductile Iron, Nickel-Plated 5																																																																																														
PVF-Coated Ductile Iron ¹ 6																																																																																														
Alloy 20 ² 7																																																																																														
Hastelloy "C" ⁶ 8																																																																																														
NEI-T and NE-I Sanitary																																																																																														
316 SS Polished ³ 2																																																																																														
316 SS Tumbled ³ 5																																																																																														
Alloy 20 (NEI-T Only) 7																																																																																														
Hastelloy "C" ⁶ (NEI-T Only) 8																																																																																														
316 SS Unpolished ³ 9																																																																																														
NE-C, NE-I and NE-D⁷																																																																																														
Buna-N 31																																																																																														
Black Neoprene 32																																																																																														
Hypalon ⁶ 33																																																																																														
FKM 34																																																																																														
Peroxide-Cured, EPDM 35																																																																																														
Natural Rubber 36																																																																																														
White Neoprene 37																																																																																														
ETM-30230 01																																																																																														
Fluorosteam 02																																																																																														
Peroxide-Cured Food Grade, EPDM 03																																																																																														
Peroxide-Cured, Buna-N 04																																																																																														
Sulfur-Cured, EPDM/Teflon ⁶ 05																																																																																														
Food Grade, EPDM 05																																																																																														
NEI-T																																																																																														
Peroxide-Cured, EPDM/Teflon ⁶ 35																																																																																														
Sulfur-Cured, EPDM/Teflon ⁶ 05																																																																																														
NE-I Sanitary All Seats Food Grade																																																																																														
Black Neoprene 32																																																																																														
FKM 34																																																																																														
EPDM 35																																																																																														
White Neoprene 37																																																																																														
Sulfur-Cured, EPDM 05																																																																																														
Handle																																																																																														
10 Position Lkg. 1 ⁴																																																																																														
Throttling Mem./ Stop 2 ⁴																																																																																														
Square Nut 5																																																																																														
2-Position Lkg. 6 ⁴																																																																																														
10-Position Sanitary (NEI-T Only) 8																																																																																														
None 9																																																																																														
10-Position Lkg. Corrosion-Resistant K																																																																																														
2-Position Lkg. Corrosion-Resistant L																																																																																														
Throttling Mem./ Stop Corrosion-Resistant M																																																																																														
Gear Operators⁵																																																																																														
Handwheel A																																																																																														
Crank 2" to 12" (50 mm to 300 mm) B																																																																																														
Chainwheel C																																																																																														
Square Nut D																																																																																														
Bare Shaft E																																																																																														

(Example: 6" (150 mm) NE-C, 200 psi, Wafer, Standard Trim with Handle – 22124-1215311)

- * Standard coating is green enamel; other coatings are available on request.
- ** 17-4 PH SS for 8" to 12" (200 mm to 300 mm) upper stem only.
- *** Except 17-4 PH upper 8" and 10" (200 mm and 250 mm).
- 1 200 psi only.
- 2 Except 285 psi.
- 3 Polished – ground to #4 dairy finish; tumbled – vibratory finish to remove as cast surface; unpolished – as cast surface.
- 4 When these options are used with NE-I sanitary butterfly valves, handles will be bronze with stainless steel (SS) parts and fasteners.
- 5 Gear operator recommended for 8" to 12" (200 mm to 300 mm) sizes in all series.
- 6 See material trademark note on page 40.
- 7 Other seat options available (consult Cameron).

SERIES NF-C

14" to 24" (350 mm to 600 mm)

Key No.	Qty.	Description	Material
1	1	Body	*
2	1	Seat	*
3	1	Disc	*
4	1	Upper Stem	*
6	1	Lower Stem	*
7	2	Spring Pin	Stainless Steel
14	1	Retainer (Spacer) +	Stainless Steel
22	1	Top O-ring	Buna-N
23	•	Stem O-ring	Buna-N
24	2	Bearing	Bronze

- * See How to Order for material choices/styles. Complete material specs are on page 32.
- Four required for throttling valves only.
- + 14" to 20" (350 mm to 500 mm) spacer.

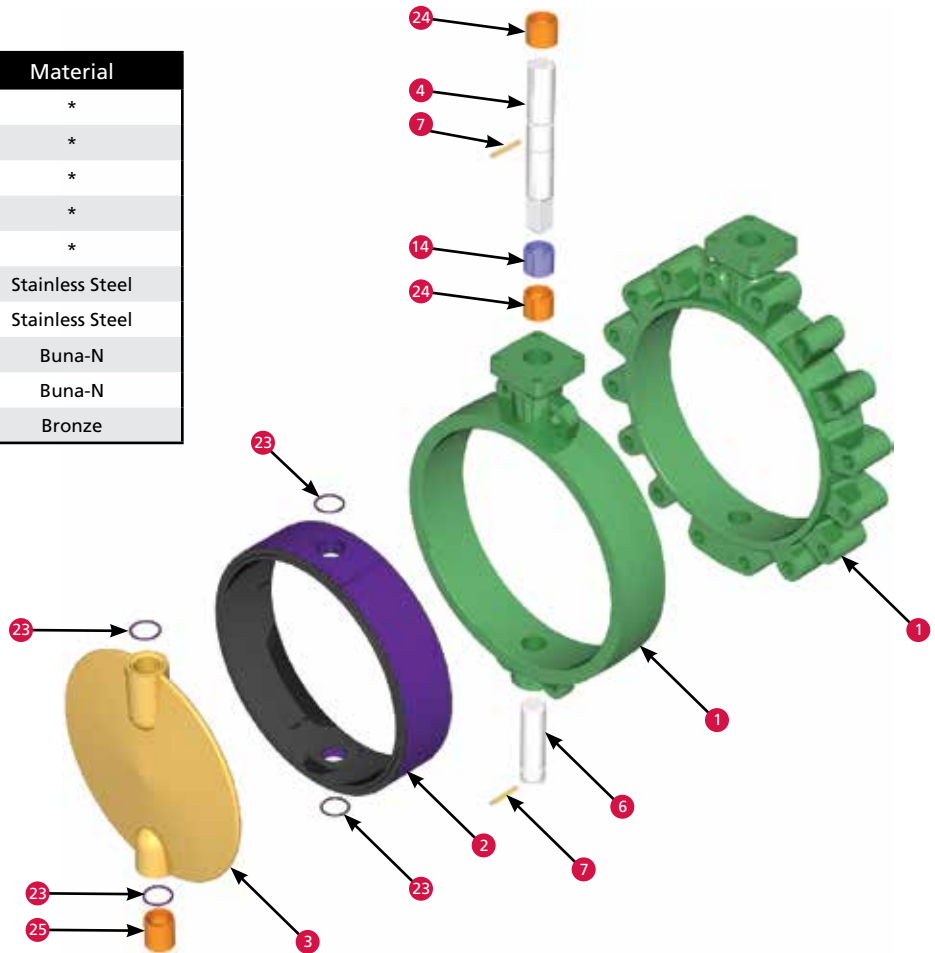

HOW TO ORDER

XXXXX Base Part Number		X Body Configuration	X Body Material*	X Stem Material	X Disc Material	XX Seat Elastomer	X Actuation		
Wafer	1	Ductile Iron (Lug)	1	316 SS	2	Buna-N	31	None	9
Lug	5	Cast Iron (Wafer)	2	Monel ²	3	Black Neoprene	32	Gear Operators	
		Aluminum Bronze (Lug)	3	Aluminum	4	Hypalon ⁶	33	Handwheel	A
		Steel (Lug)	4	Bronze	5	FKM	34	Chainwheel	C
		Stainless Steel (Lug)	8	Nickel-Plated Iron	6	EPDM	35	Square Nut	D
				PVF-Coated				Bare Shaft	E
				Ductile Iron ¹					

Based on valve series and shut-off pressure. See page 12.

(Example: 18" (450 mm) NF-C, 150 psi Lug, SS Trim, Buna-N Seat, WGO – 23822-512231A)

- * Standard coating is green enamel; other coatings are available on request.
- 1 150 psi only.
- 2 See material trademark note on page 40.

SERIES NF-C

30" and 36" (750 mm and 900 mm)

Key No.	Qty.	Description	Material
1	1	Body	*
2	1	Seat – Hard-Backed	*
3	1	Disc	*
4	1	Upper Stem	*
6	1	Lower Stem	*
7	2	Disc Screw	18-8 SS
8	1	Key	Stainless Steel
9	2	O-ring	Buna-N
14	1	Spacer	Steel
24	2	Upper Bearing	Bronze
25	1	Lower Bearing	Bronze
26	1	Thrust Collar	Bronze
27	1	Set Screw	18-8 SS
28	1	Cap	Ductile Iron
29	4	Screw	Carbon Steel
30	4	Lockwasher	Carbon Steel

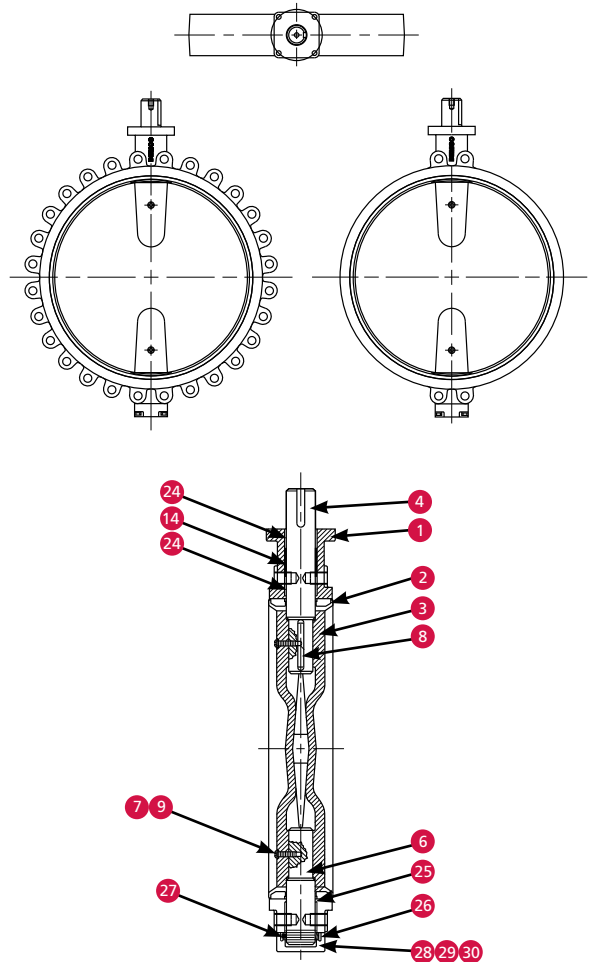

* See How to Order for material choices/styles. Complete material specs on page 32.

HOW TO ORDER

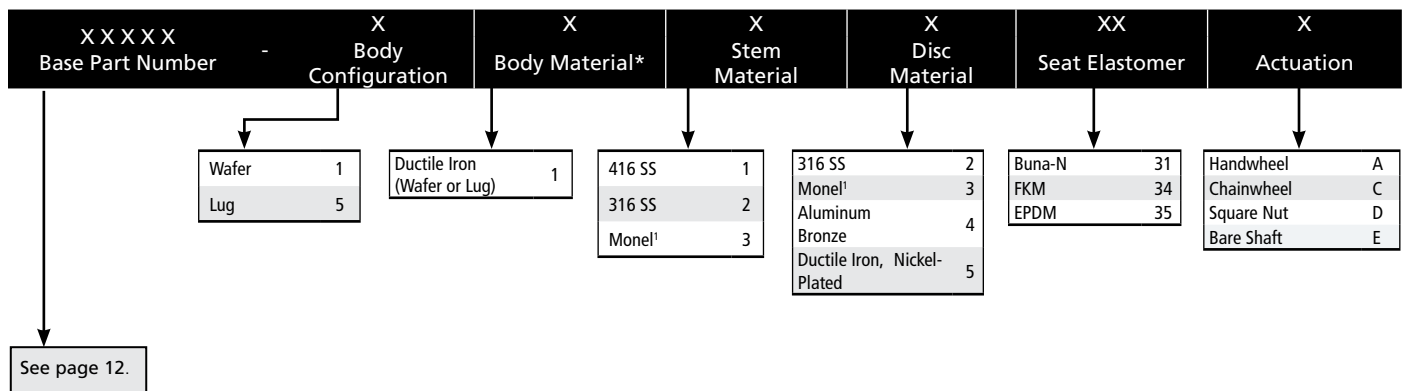

(Example: 36" (900 mm), 150 psi, Bronze Disc, EPDM Seat with Gear Op. – 24357-111435A)

* Standard coating is green enamel; other coatings are available on request.
 1 See material trademark note on page 40.

BASE PART NUMBERS AND WEIGHTS

Series NE-C, 2" to 12" (50 mm to 300 mm)*

Description	in. (mm)	2 (50)	2-1/2 (65)	3 (80)	4 (100)	5 (125)	6 (150)	8 (200)	10 (250)	12 (300)
200 psi		22119	22120	22121	22122	22123	22124	22125	22126	22127
285 psi		22225	22226	22227	22228	22229	22230	22231	22232	22233
50 psi		22234	22235	22236	22237	22238	22239	22240	22241	22242
Throttling		22243	22244	22245	22246	22247	22248	22249	22250	22251
Weight (lb – bare stem)	Wafer	5.8	7.0	7.7	11.4	14.7	17.6	28.5	47.9	71.0
	Lug	8.0	9.9	10.7	17.0	24.5	28.5	43.5	65.9	98.5

Series NE-I, 2" to 12" (50 mm to 300 mm)*

Description	in. (mm)	2 (50)	2-1/2 (65)	3 (80)	4 (100)	5 (125)	6 (150)	8 (200)	10 (250)	12 (300)
200 psi		22128	22129	22130	22131	22132	22133	22134	22135	22136
285 psi		22252	22253	22254	22255	22256	22257	22258	22259	22260
50 psi		22261	22262	22263	22264	22265	22266	22267	22268	22269
Throttling		22270	22271	22272	22273	22274	22275	22276	22277	22278
Weight (lb – bare stem)	Iron, Steel, SS	4.9	6.4	6.9	10.2	13.7	16.4	28.4	44.8	66.8
	Bronze	4.7	6.2	6.7	9.9	13.4	16.0	28.0	44.3	66.3
Wafer	Aluminum	2.8	3.4	4.1	5.9	8.7	10.8	18.2	30.4	47.2
(lb – bare stem)	Bronze	6.8	8.7	9.5	15.7	23.1	27.0	42.0	64.4	96.8
Lug	Steel, SS	7.0	8.9	9.7	16.0	23.5	27.5	42.5	64.9	97.5

Series NE-I, Sanitary 2" to 12" (50 mm to 300 mm)*

Description	in. (mm)	2 (50)	2-1/2 (65)	3 (80)	4 (100)	6 (150)	8 (200)	10 (250)	12 (300)	
200 psi		23150	23151	23152	23153	23154	23155	23156	23157	
Weight		See chart above: NE-I, 2" to 12" (50 mm to 300 mm)								

Series NE-D, 2" to 12" (50 mm to 300 mm)*

Description	in. (mm)	2 (50)	2-1/2 (65)	3 (80)	4 (100)	5 (125)	6 (150)	8 (200)	10 (250)	12 (300)
200 psi		22181	22129	25093	22183	22184	22185	22134	22186	22136
285 psi		22279	22253	25135	22281	22282	22283	22258	22284	22260
50 psi		22285	22262	25132	22287	22288	22289	22267	22290	22269
Throttling		22291	22271	25136	22293	22294	22295	22276	22296	22278
Weight (lb – bare stem) Wafer		4.9	6.4	6.9	10.2	13.7	16.4	28.4	44.8	66.8

Series NEI-T, 2" to 10" (50 mm to 250 mm)*

Description	in. (mm)	2 (50)	2-1/2 (65)	3 (80)	4 (100)	6 (150)	8 (200)	10 (250)
150 psi		24680	24681	24682	24683	24684	24685	24686
Weight (lb – bare stem)	Iron, Steel, SS	4.9	6.4	6.9	10.2	16.4	28.4	44.8
	Bronze	4.7	6.2	6.7	9.9	16.0	28.0	44.3
Wafer**	Aluminum	2.8	3.4	4.1	5.9	10.8	18.2	30.4
(lb – bare stem)	Bronze	6.8	8.7	9.5	15.7	27.0	42.0	64.4
Lug**	Steel, SS	7.0	8.9	9.7	16.0	27.5	42.5	64.9

* Gear operator recommended for 8" to 12" (200 mm to 300 mm) sizes.

** See NE-C chart above for weights of long-neck wafer and lug valves.

Series NF-C, 14" to 24" (350 mm to 600 mm)

Description	in. (mm)	14 (350)	16 (400)	18 (450)	20 (500)	24 (600)
150 psi		23820	23821	23822	23823	23824
50 psi		24440	24441	24442	24443	24444
Throttling		24445	24446	24447	24448	24449
Weight (lb – bare stem)	Wafer	102	166	214	257	401
	Lug	116	203	239	332	535

Series NF-C, 30" to 36" (750 mm to 900 mm)

Description	in. (mm)	30 (750)	36 (900)
150 psi		24141	24357
50 psi		24924	25061
Weight	Wafer	935	1500
	Lug	1050	2020

Marine valves: consult Cameron for data sheets B-255, B-256 and B-258.

MARINE SERIES

DEMCO marine butterfly valves meet all the requirements of US Coast Guard's Marine Engineering Regulations as outlined in Title 46 of the Code of Federal Regulations, Part 56 and The American Bureau of Shipping Standard, including tagging per MSS-SP-25 and testing per MSS-SP-67. All valves are shell tested at 1-1/2 times rated working pressure and seat tested at rated working pressure.

Marine Series, 2" to 36" (50 mm to 900 mm)

Description	in. (mm)	2 (50)	2-1/2 (65)	3 (80)	4 (100)	5 (125)	6 (150)	8 (200)	10 (250)	12 (300)
200 psi		22923	22924	22925	22926	22927	22928	22929	22930	22931
50 psi		22932	22933	22934	22935	22936	22937	22938	22939	22940
285 psi		22914	22915	22916	22917	22918	22919	22920	22921	22922
Weight (lb – bare stem) NE-C Long-Neck Body										
Wafer	Gray Iron	5.8	7.0	7.7	11.4	14.7	17.6	28.5	47.9	71.0
Lug	Ductile Iron	8.0	9.9	10.7	17.0	24.5	28.5	43.5	65.9	98.5
NE-I Short-Neck Body										
Wafer	Iron, Steel, SS	4.9	6.4	6.9	10.2	13.7	16.4	28.4	44.8	66.8
	Bronze	4.7	6.2	6.7	9.9	13.4	16.0	28.0	44.3	66.3
Lug	Bronze	6.8	8.7	9.5	15.7	23.1	27.0	42.0	64.4	96.8
	SS, Steel	7.0	8.9	9.7	16.0	23.5	27.5	42.5	64.9	97.5

Description	in. (mm)	14 (350)	16 (400)	18 (450)	20 (500)	24 (600)	30 (750)	36 (900)
150 psi		24611	24612	24613	24614	24615	2227182	2227183
50 psi		24653	24654	24655	24656	24657	2227184	2227185
Weight (lb – bare stem) NF-C Long-Neck Body								
Lug	Ductile Iron	116	203	239	332	535	1050	2020
	Bronze	113	199	235	325	525	N/A	N/A

HOW TO ORDER

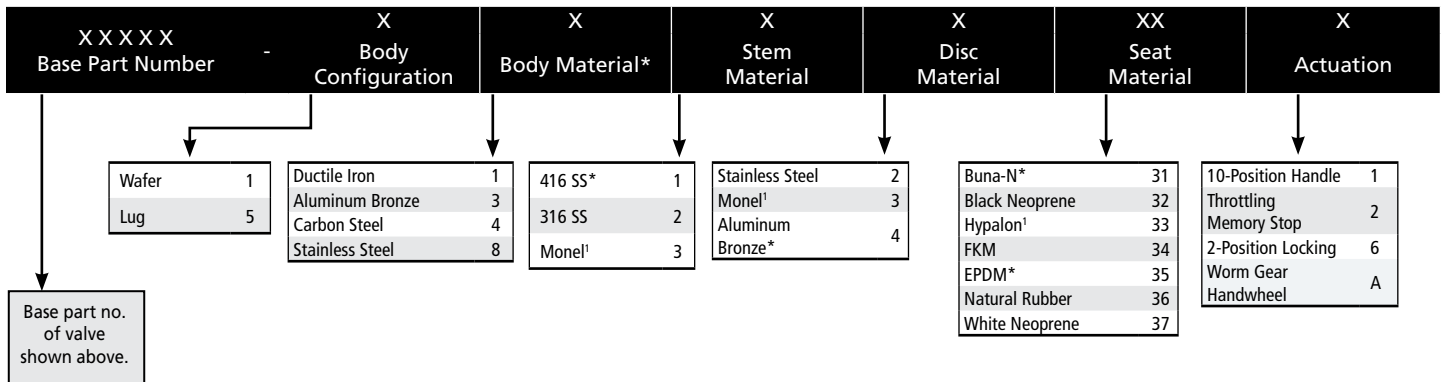

(Example: 6" (150 mm) 200 psi Wafer, Standard Trim with 10-Position Handle – 22928-1114311)

* Standard base trim options.

** Wafer 2" to 12" (50 mm to 300 mm) only.

Lug 2" to 36" (50 mm to 900 mm).

Note: 30" and 36" (750 mm to 900 mm) available with ductile iron lug body only.

1 See material trademark note on page 40.

COMPONENT PARTS LIST: SERIES NE-C, NE-I, NE-D

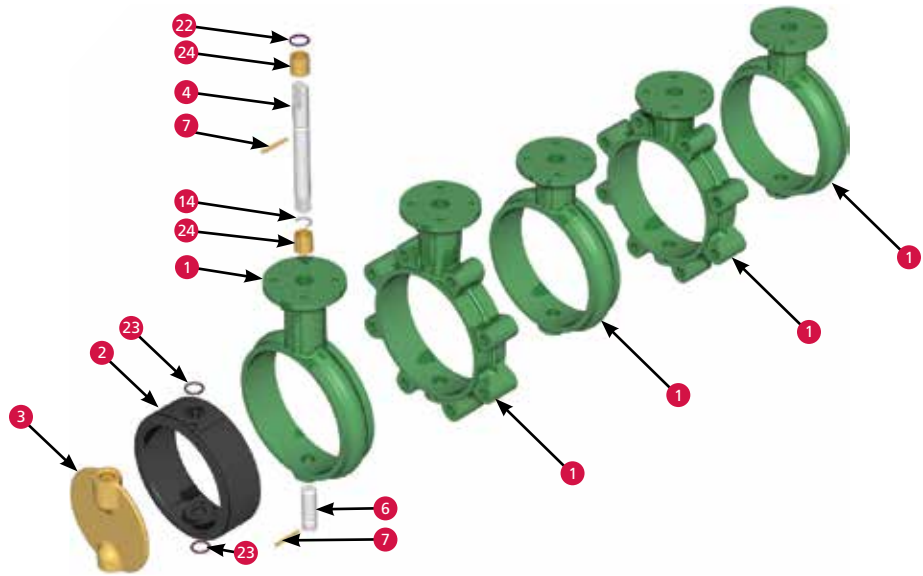

Parts List for Series NE-C, NE-I and NE-D (Consult a Cameron representative for replacement parts for Series NE, NE-S and NE-N.)

Key No.	Description	2" (50 mm)	2-1/2" (65 mm)	3" (80 mm)	4" (100 mm)	5" (125 mm)	6" (150 mm)	8" (200 mm)	10" (250 mm)	12" (300 mm)		
1	Body	NE-C Wafer	22137-012	22138-012	22139-012	22140-012	22141-012	22142-012	22143-012	22144-012	22145-012	
		Options	ASTM A48 Gray Iron -012									
		NE-C Lug	21986-051	21987-051	21988-051	21989-051	21990-051	21991-051	21992-051	21993-051	21994-051	21994-051
		Options	ASTM A395 Ductile Iron -051									
		NE-I Wafer	22681-01x	22682-01x	22683-01x	22684-01x	22685-01x	22686-01x	22687-01x	22688-01x	22689-01x	22689-01x
		Options	ASTM A395 Ductile Iron -011, ASTM B148 Aluminum Bronze -013, ASTM A216 WCB Steel -014, ASTM B179 Aluminum -015, DI/ENC -016, ASTM A351 SS -018									
		NE-I Lug	22695-05x	22696-05x	22697-05x	22698-05x	22699-05x	22700-05x	22701-05x	22702-05x	22703-05x	22703-05x
		Options	ASTM B148 Aluminum Bronze -053, ASTM A216 WCB Steel -054, ASTM A351 SS -058									
		NE-D Wafer	22187-021	22682-011	20594-021	22189-021	22190-021	22191-021	22687-011	22192-021	22689-011	22689-011
		Options	ASTM A395 Ductile Iron -0x1									
2	Seat		1786-xxx	1788-xxx	1790-xxx ⁶	1792-xxx	1794-xxx	1002-xxx	1798-xxx	1815-xxx	1817-xxx	
		Options	Buna-N -031, Black Neoprene -032, Hypalon ⁷ -033, FKM -034, EPDM ¹ -135, Natural Rubber -036, White Neoprene -037, Peroxide-Cured Buna-N -231, Fluorosteam -244, ETM-30230 -331									
3	Disc	200 psi	22045-0xx	22046-0xx	22047-0xx	22048-0xx	22049-0xx	22050-0xx	22051-0xx	22052-0xx	22053-0xx	
		285 psi	22196-0xx	22197-0xx	22198-0xx	22199-0xx	22200-0xx	22201-0xx	22202-0xx	22203-0xx	22204-0xx	
		50 psi	22205-0xx	22206-0xx	22207-0xx	22208-0xx	22209-0xx	22210-0xx	22211-0xx	22212-0xx	22213-0xx	
		Throttling	22214-0xx	22215-0xx	22216-0xx	22217-0xx	22218-0xx	22219-0xx	22220-0xx	22221-0xx	22222-0xx	
		Options	316 SS -002, Monel -003, Nickel-Plated Ductile Iron -005, Alloy 20 ² -007, Hastelloy C ⁷ -008, Aluminum Bronze ³ -014									
		PVF-Coated, 200 psi	22714-001	22715-001	22716-001	22717-001	22718-001	22719-001	22720-001	22721-001	22722-001	22722-001
		Options	316 SS -002, Monel -003, Nickel-Plated Ductile Iron -005, Alloy 20 ² -007, Hastelloy C ⁷ -008, Aluminum Bronze ³ -014									
4	Upper Stem	NE-C	22066-00x	22067-00x	22068-00x	22068-00x	22069-00x	22070-00x	22071-00x	22072-00x	22072-00x	
		NE-I	22073-00x	22074-00x	22075-00x	22075-00x	22076-00x	22077-00x	22078-00x	22079-00x	22079-00x	
		NE-D	22073-00x	22074-00x	22193-00x	22194-00x	22195-00x	22077-00x	22078-00x	22079-00x	22079-00x	
	Upper Stem -Utility Top	NE-C	22334-00x	22335-00x	22336-00x	22336-00x	22337-00x	22338-00x	22339-00x	22340-00x	22340-00x	
		NE-I	22341-00x	22342-00x	22343-00x	22343-00x	22344-00x	22345-00x	22346-00x	22347-00x	22347-00x	
6	Lower Stem		22080-00x	22081-00x	22082-00x	22082-00x	22083-00x	22084-00x	22085-00x	22086-00x	22086-00x	
		Stem Material Options	416 SS -001, 316 SS ⁴ -002, Monel ⁷ -003									
7	Spring Pin (2)	302 SS	5448-18720			5448-18724			5448-25028			
14	Retainer	Stainless Steel	22117		13704		13705		13706		13707	
22	Top O-ring	Buna-N	5526-114		5526-115		5526-117		5526-119		5526-125	
23	Stem O-ring ⁵	Buna-N	5526-113		5526-115		5526-212		5526-214		5526-220	
24	Bearing (2)	Bronze	22526-001		22118-001		13112-001		13115-001		13116-001	

- 1 EPDM seat options: Standard – Peroxide-Cured -135, Food Grade -035 Peroxide-Cured, Sulfur-Cured -235.
- 2 Alloy 20 not available for 285 psi.
- 3 8" to 12" (200 mm to 300 mm), 285 psi Aluminum Bronze, use -024.
- 4 8" to 12" (200 mm to 300 mm), Upper Stem 17-4 PH SS (part number suffix -012), Lower Stem 316 SS.
- 5 Four required for throttling (0 psi) valves only.
- 6 3" (80 mm) NE-D seat part number 25095-xxx.
- 7 See material trademark note on page 40

COMPONENT PARTS LIST: SERIES NF-C

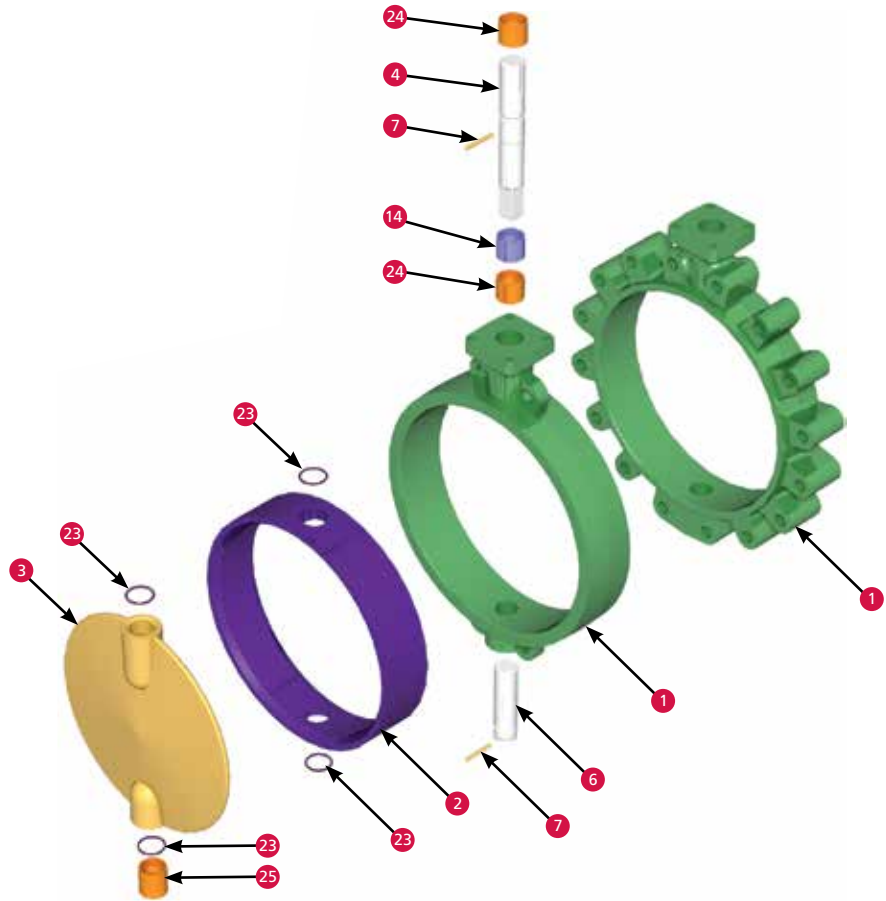

Part List for Series NF-C, (Consult a Cameron representative for replacement parts for Series NF.)

Key No.	Qty.	Description		14" (350 mm)	16" (400 mm)	18" (450 mm)	20" (500 mm)	24" (600 mm)	Material
1	1	Body	Lug	23827-051	23911-051	23901-051	23891-051	23875-051	Ductile Iron (Lug) -051
			Wafer	23825-012	23907-012	23899-012	23881-012	23873-012	Cast Iron (Wafer) -012
2	1	Seat		23829-03x	23913-03x	23903-03x	23893-03x	7103-03x	Buna-N -031 Blk. Neoprene -032 Hypalon ⁴ -033, FKM -034 EPDM ³ -X35
3	1	Disc	150 psi	23830-0xx	23915-0xx	23905-0xx	23895-0xx	23877-0xx	316 SS -002 Monel ⁴ -003
			50 psi	24450-0xx	24451-0xx	24452-0xx	24453-0xx	24454-0xx	Aluminum Bronze -014
			Throttling	24455-0xx	24456-0xx	24457-0xx	24458-0xx	24459-0xx	Nickel-Plated Iron -005
			PVF-Coated	24460-001	24461-001	24462-001	24463-001	24464-001	PVF-Coated Iron -001
4	1	Upper Stem		23833-00x	23917-00x	23897-00x	23897-00x	23879-00x	416 SS -001, 316 SS -002
6	1	Lower Stem		23834-00x	23918-00x	23898-00x	23898-00x	23880-00x	Monel ⁴ -003
7	2	Spring Pin		5446-25040	5446-25040	5446-25048	5446-25048	5446-25064	Stainless Steel
14	1	Retainer (Spacer) ²		5502-137	5502-150	5502-175	5502-175	24470	Steel
23	Note 1	Disc O-ring		5526-220	5526-223	5526-328	5526-328	5526-331	Buna-N
24			2	Upper Bearing	5086-044	5086-050	5086-048	5086-048	5086-046
25	1	Lower Bearing		5086-045	5086-051	5086-049	5086-049	5086-047	Bronze

1 Four required for throttling valves only.

2 14" to 20" (350 mm to 500 mm) retainer, 24" (600 mm) spacer.

3 EPDM seat options: Standard – Peroxide-Cured -135, Food Grade -035 Peroxide-Cured, Sulfur-Cured -235.

4 See material trademark note on page 40.

SERIES NE-C DIMENSIONAL DATA

2" to 12" (50 mm to 300 mm)

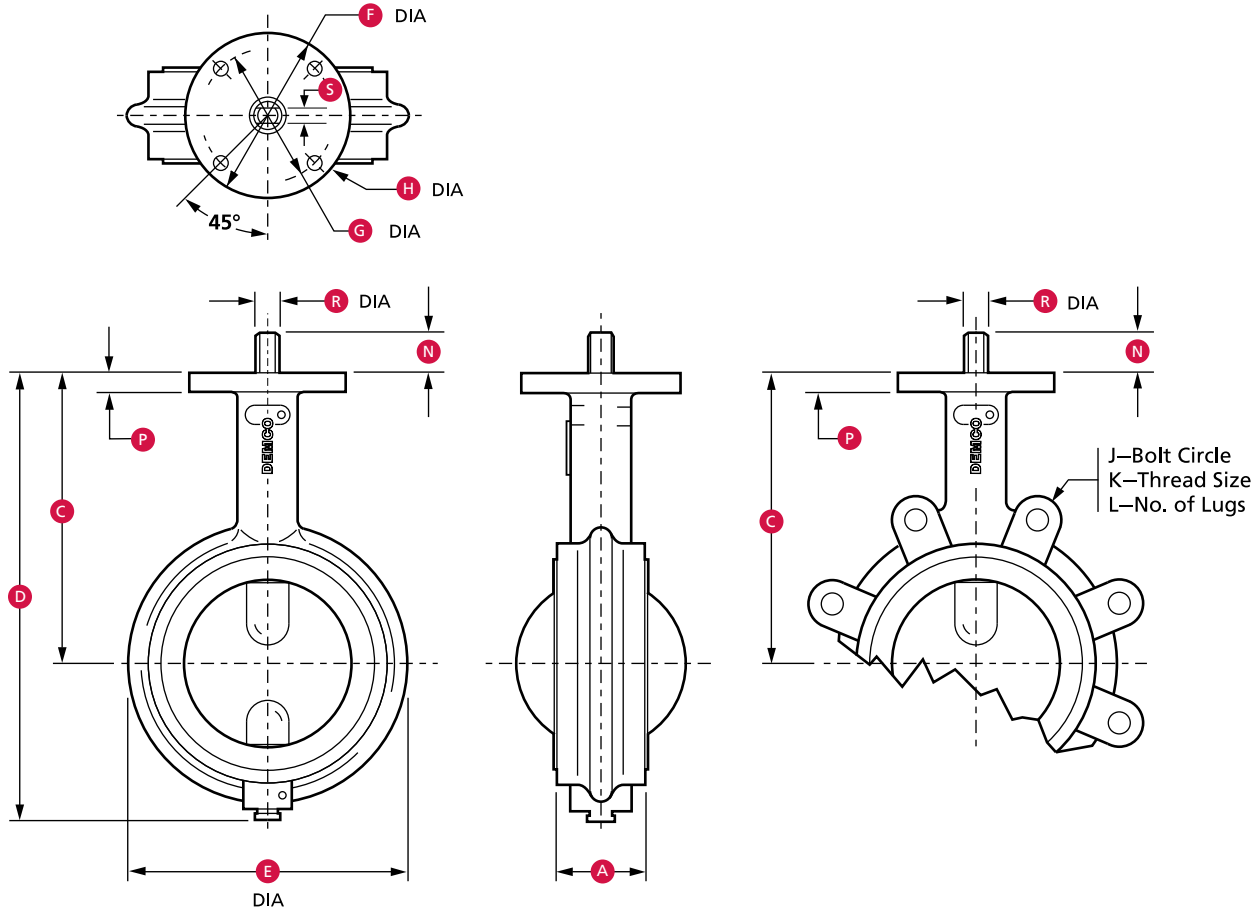

Dimensional Data

Size in.	A	C	D	E	F	G	H	J	K	L	N	P	R	S
2	1.74	5.62	8.44	4.12	4.00	3.25	0.408	4.75	5/8 - 11	4	1.00	0.44	0.625	0.375
2-1/2	1.86	6.12	9.19	4.88	4.00	3.25	0.408	5.50	5/8 - 11	4	1.00	0.44	0.625	0.375
3	1.86	6.38	9.69	5.38	4.00	3.25	0.408	6.00	5/8 - 11	4	1.00	0.44	0.625	0.375
4	2.11	7.12	11.00	6.88	4.00	3.25	0.408	7.50	5/8 - 11	8	1.00	0.44	0.625	0.375
5	2.24	7.75	12.12	7.75	4.00	3.25	0.408	8.50	3/4 - 10	8	1.25	0.44	0.838	0.500
6	2.24	8.25	13.25	8.75	4.00	3.25	0.408	9.50	3/4 - 10	8	1.25	0.44	0.838	0.500
8	2.54	9.44	15.56	11.00	6.00	5.00	0.533	11.75	3/4 - 10	8	1.38	0.56	0.838	0.500
10	2.74	11.25	18.69	13.38	6.00	5.00	0.533	14.25	7/8 - 9	12	1.38	0.56	0.963	0.625
12	3.24	12.19	21.69	16.12	6.00	5.00	0.533	17.00	7/8 - 9	12	1.38	0.56	1.338	0.750
Size mm														
50	44	143	214	105	102	83	10.36	121	5/8 - 11	4	25	11.2	15.88	9.53
65	47	155	233	124	102	83	10.36	140	5/8 - 11	4	25	11.2	15.88	9.53
80	47	162	246	137	102	83	10.36	152	5/8 - 11	4	25	11.2	15.88	9.53
100	54	181	279	175	102	83	10.36	191	5/8 - 11	8	25	11.2	15.88	9.53
125	57	197	308	197	102	83	10.36	216	3/4 - 10	8	32	11.2	21.29	12.70
150	57	210	337	222	102	83	10.36	241	3/4 - 10	8	32	11.2	21.29	12.70
200	65	240	395	279	152	127	13.54	298	3/4 - 10	8	35	14.2	21.29	12.70
250	70	286	475	340	152	127	13.54	362	7/8 - 9	12	35	14.2	24.46	15.88
300	82	310	551	409	152	127	13.54	432	7/8 - 9	12	35	14.2	33.99	19.05

Note: For general dimensions, see page 28.

SERIES NF-C DIMENSIONAL DATA

14" to 24" (350 mm to 600 mm)

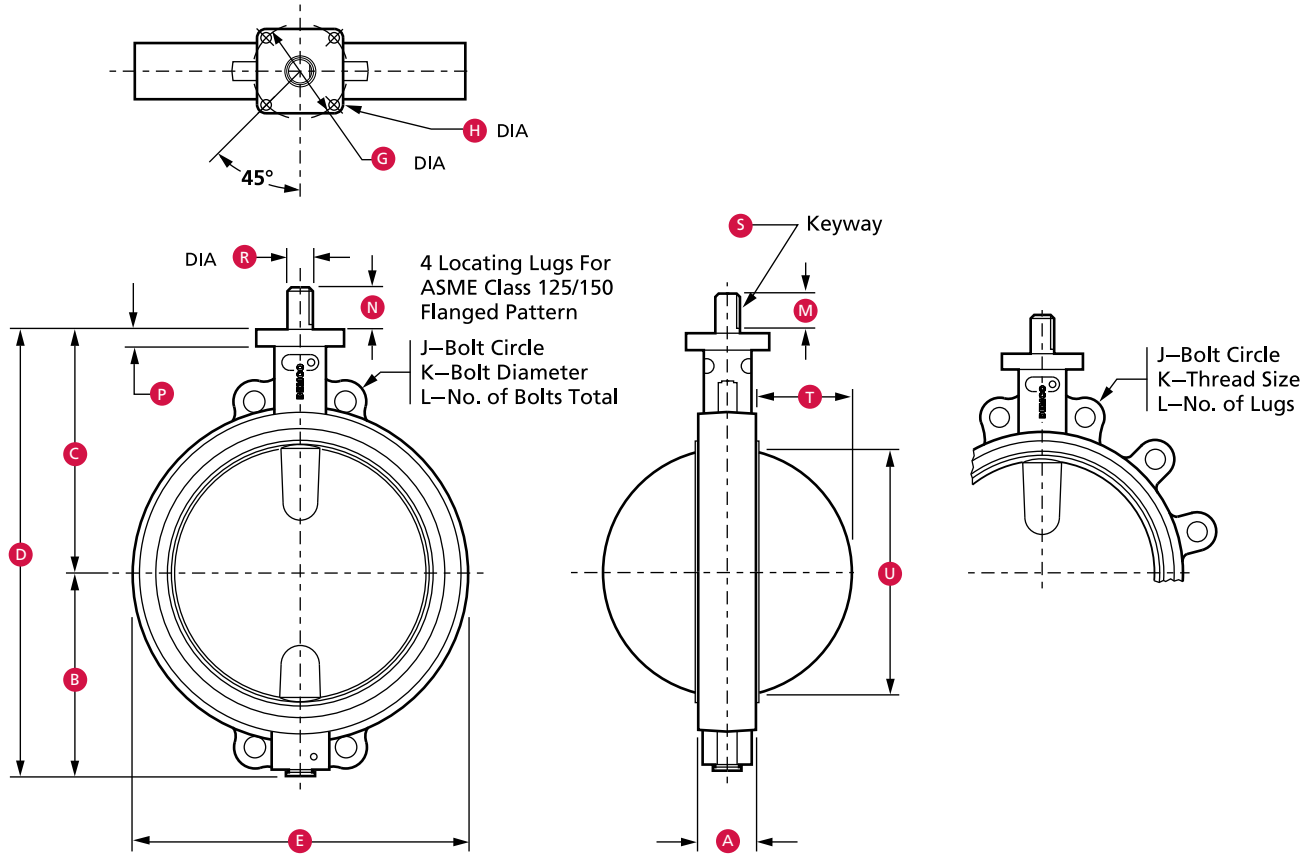

Dimensional Data

Size in.	A	B	C	D	E	G	H	J	K	L	M	N	P	R	S	T	U
14	3.00	10.63	12.75	23.4	16.20 17.3*	5.00	0.56	18.75	1 - 8 1*	12	2.00	2.25	0.88	1.375	5/16 x 5/32	5.12	12.89
16	4.00	11.66	13.75	25.4	18.16 19.2*	5.00	0.56	21.25	1 - 8 1*	16	2.00	2.25	0.88	1.625	3/8 x 3/16	5.65	14.76
18	4.50	12.96	14.75	27.7	20.35 21.4*	6.50	0.81	22.75	1-1/8 - 7 1-1/8*	16	2.50	2.75	1.00	1.875	1/2 x 3/16	6.37	16.63
20	5.00	13.97	15.75	29.7	22.63 23.6*	6.50	0.81	25.00	1-1/8 - 7 1-1/8*	20	2.50	2.75	1.00	1.875	1/2 x 3/16	7.12	18.58
24	6.00	16.19	19.00	35.2	27.31 28.3*	6.50	0.81	29.50	1-1/4 - 7 1-1/4*	20	2.50	3.00	1.00	1.875	1/2 x 3/16	8.67	22.56
Size mm																	
350	76	270	324	594	411 439*	127	14.2	476	1 - 8 1*	12	51	57	22.4	34.93	7.94 x 3.97	130	327
400	102	296	349	645	461 488*	127	14.2	540	1 - 8 1*	16	51	57	22.4	41.28	9.53 x 4.76	144	375
450	114	329	375	704	517 544*	165	20.6	578	1-1/8 - 7 1-1/8*	16	64	57	25.4	47.63	12.70 x 4.76	162	422
500	127	355	400	754	575 599*	165	20.6	635	1-1/8 - 7 1-1/8*	20	64	57	25.4	47.63	12.70 x 4.76	181	472
600	152	411	483	894	694 719*	165	20.6	749	1-1/4 - 7 1-1/4*	20	64	76	25.4	47.63	12.70 x 4.76	220	573

* Wafer valve dimension is the bottom figure. Lug valve dimension is the top figure.
Note: For general dimensions, see page 28.

SERIES NF-C DIMENSIONAL DATA

30" to 36" (750 mm to 900 mm)

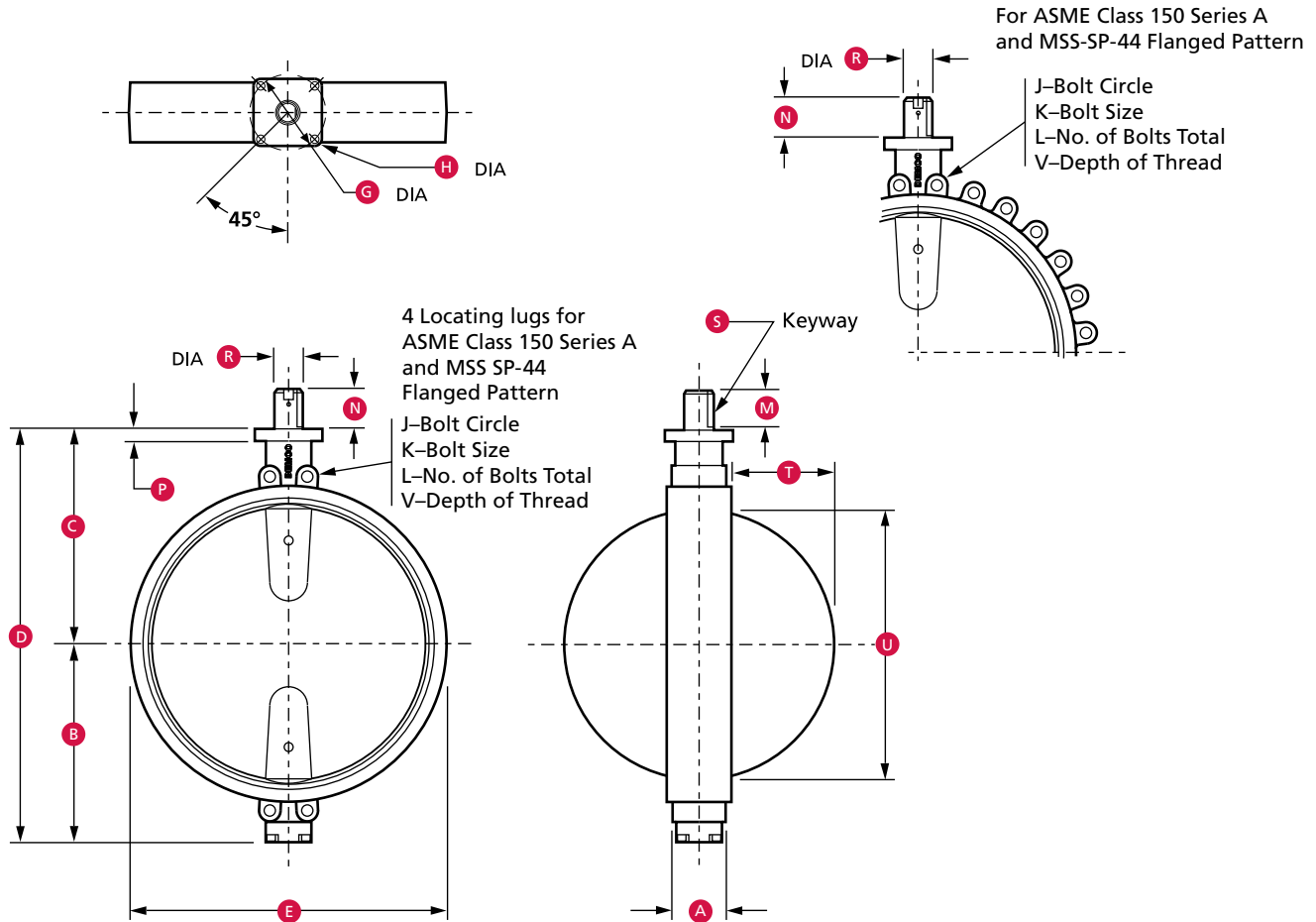

Dimensional Data

Size in.	A	B	C	D	E	G	H	J	K	L	M	N	P	R	S	T	U	V
30	6.50	21.2	23.0	44.2	34.1	8.00	0.69	36.00	1-1/4 - 7UNC	28	3.4	3.7	1.2	3.000	3/4 x 3/8	11.45	28.55	1.750
36	7.88	25.0	27.8	52.8	40.5	10.25	0.81	42.75	1-1/2 - 6UNC	32	4.0	4.4	1.5	3.625	7/8 x 7/16	13.86	34.71	1.750
Size mm																		
750	165	538	584	1123	866	203	17.53	914	1-1/4 - 7UNC	28	86	94	30.5	76.2	19.05 x 9.53	291	725	44.45
900	200	635	706	1342	1029	260	20.57	1086	1-1/2 - 6UNC	32	102	112	38.1	92.1	22.23 x 11.11	352	882	44.45

Note: For general dimensions, see page 28.

SERIES NE-D DIMENSIONAL DATA

2" to 12" (50 mm to 300 mm)

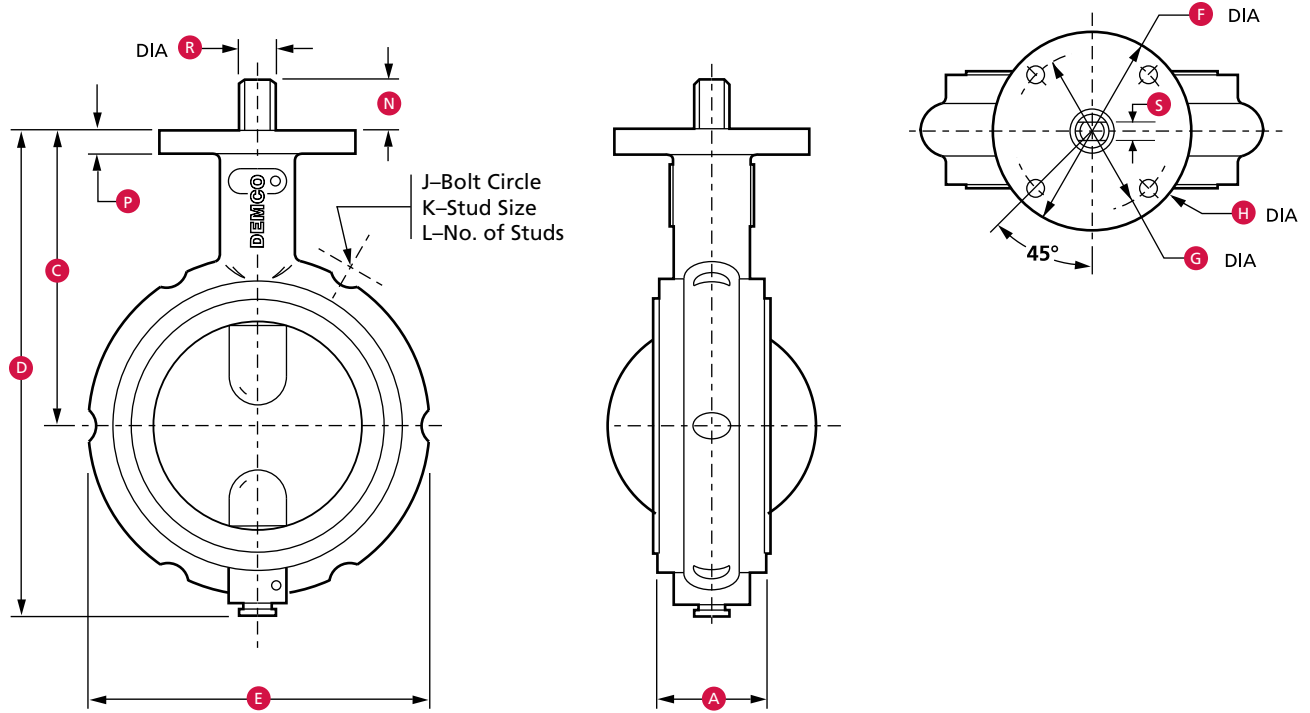

Dimensional Data

Size in.	A	C	D	E	F	G	H	J	K	L	N	P	R	S
2	1.74	3.94	6.75	4.12	4.00	3.25	0.408	4.27	3/8	4	1.00	0.44	0.625	0.375
2-1/2	1.86	4.44	7.50	4.88	4.00	3.25	0.408	5.31	3/8	4	1.00	0.44	0.625	0.375
3	1.86	4.88	8.19	5.38	4.00	3.25	0.408	4.91	3/8	6	1.00	0.44	0.625	0.375
4	2.11	6.00	9.88	6.88	4.00	3.25	0.408	7.03	1/2	6	1.00	0.44	0.625	0.375
5	2.24	6.00	10.38	7.75	4.00	3.25	0.408	7.56	1/2	6	1.25	0.44	0.838	0.500
6	2.24	6.50	11.50	8.75	4.00	3.25	0.408	9.16	1/2	8	1.25	0.44	0.838	0.500
8	2.54	8.06	14.19	11.00	6.00	5.00	0.533	11.72	5/8	8	1.38	0.56	0.838	0.500
10	2.74	9.97	17.41	13.38	6.00	5.00	0.533	13.72	5/8	8	1.38	0.56	0.963	0.625
12	3.24	10.91	20.41	16.12	6.00	5.00	0.533	16.62	1/2	12	1.38	0.56	1.338	0.750
Size mm														
50	44	100	171	105	102	83	10.36	108	10	4	25	11.2	15.88	9.53
65	47	113	191	124	102	83	10.36	135	10	4	25	11.2	15.88	9.53
80	47	124	208	137	102	83	10.36	125	10	6	25	11.2	15.88	9.53
100	54	152	251	175	102	83	10.36	179	15	6	25	11.2	15.88	9.53
125	57	152	264	197	102	83	10.36	192	15	6	32	11.2	21.29	12.70
150	57	165	292	222	102	83	10.36	233	15	8	32	11.2	21.29	12.70
200	65	205	360	279	152	127	13.54	298	16	8	35	14.2	21.29	12.70
250	70	253	442	340	152	127	13.54	348	16	8	35	14.2	24.46	15.88
300	82	277	518	409	152	127	13.54	422	15	12	35	14.2	33.99	19.05

Note: For general dimensions, see page 28.

SERIES NE-I, NE-I SANITARY
 2" to 12" (50 mm to 300 mm)

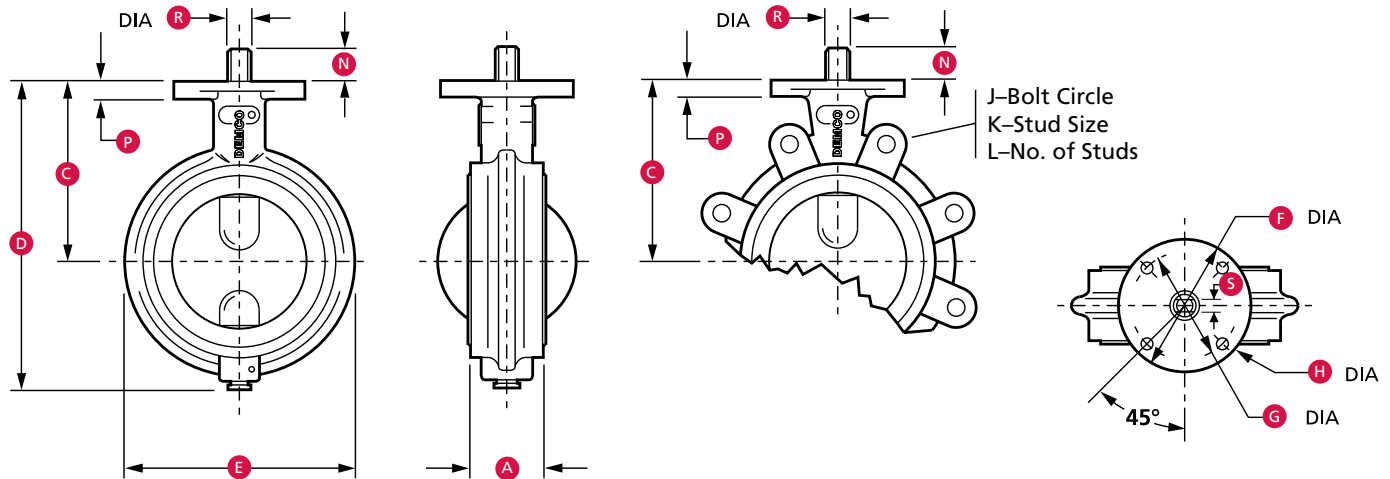

Dimensional Data

Size in.	A	C	D	E	F	G	H	J	K	L	N	P	R	S
2	1.74	3.94	6.75	4.12	4.00	3.25	0.408	4.75	5/8 - 11	4	1.00	0.44	0.625	0.375
2-1/2	1.86	4.44	7.50	4.88	4.00	3.25	0.408	5.50	5/8 - 11	4	1.00	0.44	0.625	0.375
3	1.86	4.69	8.00	5.38	4.00	3.25	0.408	6.00	5/8 - 11	4	1.00	0.44	0.625	0.375
4	2.11	5.44	9.31	6.88	4.00	3.25	0.408	7.50	5/8 - 11	8	1.00	0.44	0.625	0.375
5*	2.24	6.38	10.75	7.75	4.00	3.25	0.408	8.50	3/4 - 10	8	1.25	0.44	0.838	0.500
6	2.24	6.88	11.88	8.75	4.00	3.25	0.408	9.50	3/4 - 10	8	1.25	0.44	0.838	0.500
8	2.54	8.06	14.19	11.00	6.00	5.00	0.533	11.75	3/4 - 10	8	1.38	0.56	0.838	0.500
10	2.74	9.97	17.41	13.38	6.00	5.00	0.533	14.25	7/8 - 9	12	1.38	0.56	0.963	0.625
12	3.24	10.91	20.41	16.12	6.00	5.00	0.533	17.00	7/8 - 9	12	1.38	0.56	1.338	0.750
Size mm														
50	44	100	171	105	102	83	10.36	121	5/8 - 11	4	25	11.2	15.88	9.53
65	47	113	191	124	102	83	10.36	140	5/8 - 11	4	25	11.2	15.88	9.53
80	47	119	203	137	102	83	10.36	152	5/8 - 11	4	25	11.2	15.88	9.53
100	54	138	236	175	102	83	10.36	191	5/8 - 11	8	25	11.2	15.88	9.53
125*	57	162	273	197	102	83	10.36	216	3/4 - 10	8	32	11.2	21.29	12.70
150	57	175	302	222	102	83	10.36	241	3/4 - 10	8	32	11.2	21.29	12.70
200	65	205	360	279	152	127	13.54	298	3/4 - 10	8	35	14.2	21.29	12.70
250	70	253	442	340	152	127	13.54	362	7/8 - 9	12	35	14.2	24.46	15.88
300	82	277	518	409	152	127	13.54	432	7/8 - 9	12	35	14.2	33.99	19.05

* NE-I sanitary 5" (125 mm) not available.
 Note: For general dimensions, see page 28.

SERIES NEI-T

2" to 10" (50 mm to 250 mm)

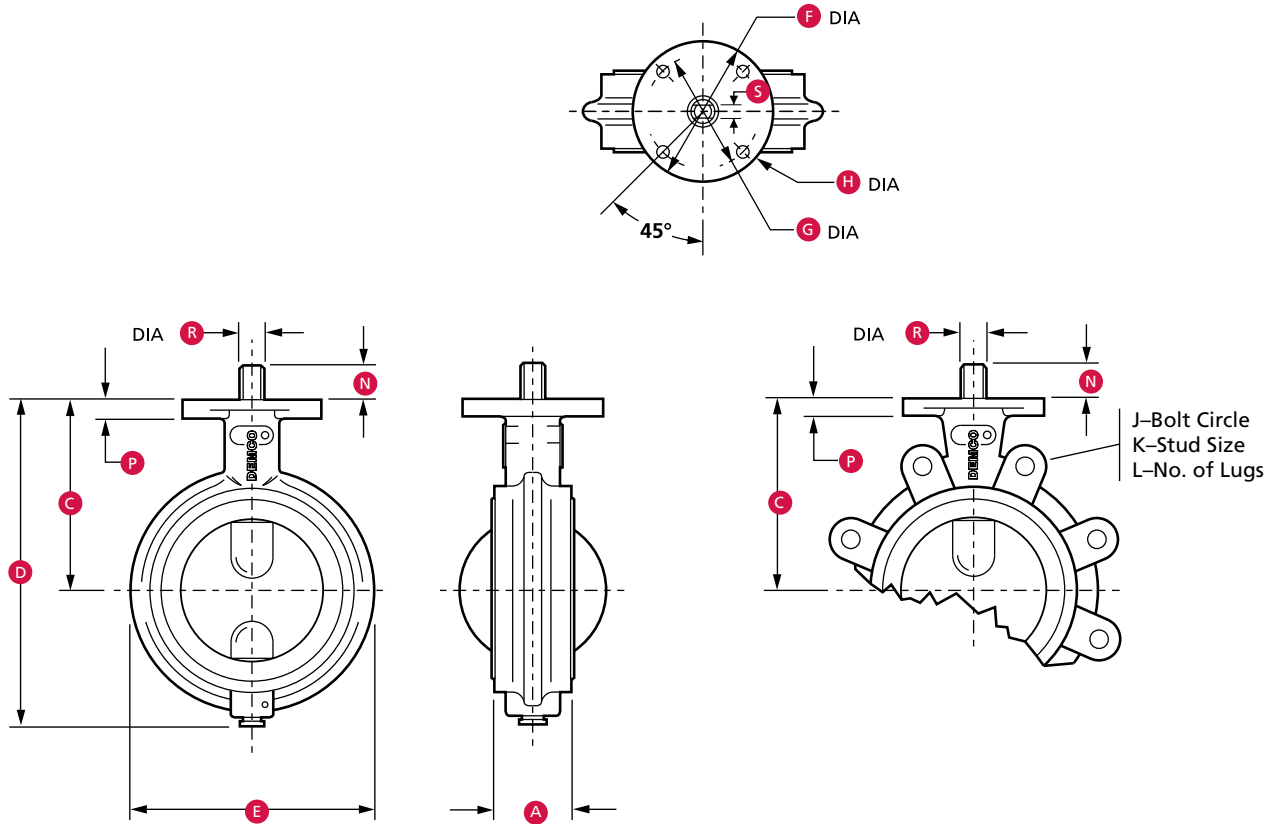

Dimensional Data

Size in.	A	C	D	E	F	G	H	J	K	L	N	P	R	S
2	1.74	3.94	6.75	4.12	4.00	3.25	0.408	4.75	5/8 - 11	4	1.00	0.44	0.625	0.375
2-1/2	1.86	4.44	7.50	4.88	4.00	3.25	0.408	5.50	5/8 - 11	4	1.00	0.44	0.625	0.375
3	1.86	4.69	8.00	5.38	4.00	3.25	0.408	6.00	5/8 - 11	4	1.00	0.44	0.625	0.375
4	2.11	5.44	9.31	6.88	4.00	3.25	0.408	7.50	5/8 - 11	8	1.00	0.44	0.625	0.375
6	2.24	6.88	11.88	8.75	4.00	3.25	0.408	9.50	3/4 - 10	8	1.25	0.44	0.838	0.500
8	2.54	8.06	14.19	11.00	6.00	5.00	0.533	11.75	3/4 - 10	8	1.38	0.56	0.838	0.500
10	2.74	9.97	17.41	13.38	6.00	5.00	0.533	14.25	7/8 - 9	12	1.38	0.56	0.963	0.625
Size mm														
50	44	100	171	105	102	83	10.36	121	5/8 - 11	4	25	11.2	15.88	9.53
65	47	113	191	124	102	83	10.36	140	5/8 - 11	4	25	11.2	15.88	9.53
80	47	119	203	137	102	83	10.36	152	5/8 - 11	4	25	11.2	15.88	9.53
100	54	138	236	175	102	83	10.36	191	5/8 - 11	8	25	11.2	15.88	9.53
150	57	175	302	222	102	83	10.36	241	3/4 - 10	8	32	11.2	21.29	12.70
200	65	205	360	279	152	127	13.54	298	3/4 - 10	8	35	14.2	21.29	12.70
250	70	253	442	340	152	127	13.54	362	7/8 - 10	12	35	14.2	24.46	15.88

Note: For general dimensions, see page 28.

HANDLES

HOW TO ORDER (XXXXX - 00X)

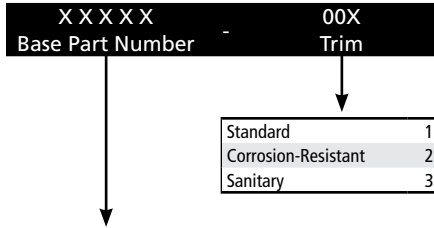

Description	in. (mm)	2 to 4 (50 to 100)	5 to 6 (125 to 150)	8 (200)	10 (250)	12 (300)
10-Position, Standard, CR		24227	24228	24229	24230	24231
2-Position, Standard, CR		24232	24233	24234	24235	24236
10-Position, Sanitary		22319	22320	22321	22322	22323
2-Position, Sanitary		22324	22325	22326	22327	22328
Throttling, Standard, CR		24252	24253	24254	24255	24256
Throttling, Sanitary		22329	22330	22331	22332	22333
Square Nut, Standard		23356	23357	23358	23359	22360
Weight (lb)		2.3	2.9	6.5	6.5	6.5

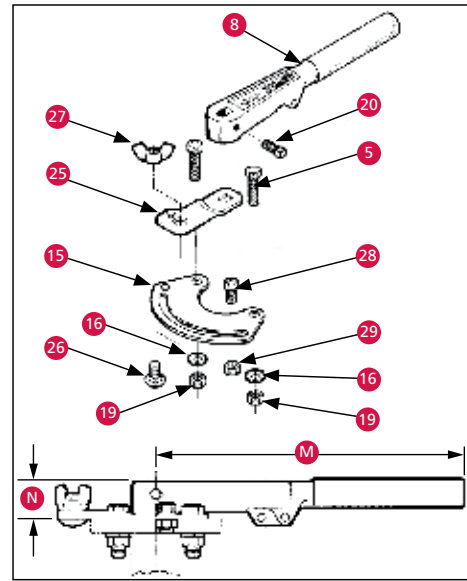

Infinite Throttling with Memory Stop Handle

Dimension	in. (mm)	2 to 4 (50 to 100)	5 to 6 (125 to 150)	8 to 12 (200 to 300)
M		9.50 (241)	11.00 (279)	15.00 (381)
N		0.85 (21.6)	1.07 (27.2)	1.13 (28.7)

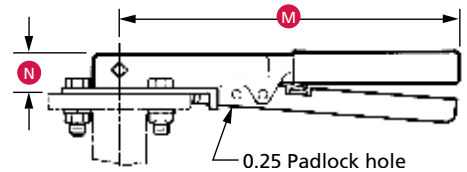

2-Position/10-Position Locking Handles

Dimension	in. (mm)	2 to 4 (50 to 100)	5 to 6 (125 to 150)	8 to 12 (200 to 300)
M		9.50 (241)	11.00 (279)	15.00 (381)
N		0.87 (22.1)	1.07 (27.2)	1.13 (28.7)

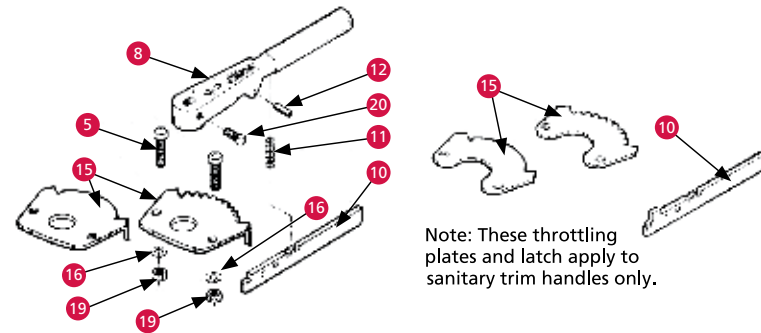

Note: These throttling plates and latch apply to sanitary trim handles only.

2-Position/10-Position Locking Handles

Key No.	Description	Material		
		Standard	Corrosion-Resistant	Sanitary
5	Screw	Steel	Stainless Steel	Stainless Steel
8	Handle	Ductile Iron	Ductile Iron	Bronze
10	Latch	Zinc-Plated Steel	Stainless Steel	Stainless Steel
11	Spring	Spring Steel	Stainless Steel	Stainless Steel
12	Spring Pin	Spring Steel	Stainless Steel	Stainless Steel
15	Throttle Plate	Zinc-Plated Steel	Stainless Steel	Stainless Steel
16	Lockwasher	Steel	Stainless Steel	Stainless Steel
19	Nut	Steel	Stainless Steel	Stainless Steel
20	Set Screw	Steel	Stainless Steel	Stainless Steel
25*	Throttling Tab	Zinc-Plated Steel	Stainless Steel	Stainless Steel
26*	Carriage Bolt	Steel	Stainless Steel	Stainless Steel
27*	Wing Nut	Steel	Stainless Steel	Stainless Steel
28*	Screw	Steel	Stainless Steel	Stainless Steel
29*	Nut	Steel	Stainless Steel	Stainless Steel

* For throttling, memory stop handle only.

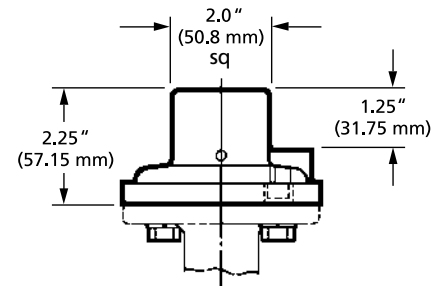

Square Nut Handle

Description	Material
Square Nut Hub	Ductile Iron
Throttle Plate	Steel
Screw	Steel
Set Screw	Steel
Lock Washer	Spring Steel

WORM GEAR OPERATORS

Manual worm gear operators are self-locking in all positions. Adjustment screws stop travel at open and closed positions. Position indicator is standard on all models. Gearing is permanently lubricated.

Gray iron weatherproof case and cover enclose a ductile iron gear and hardened steel worm supported by bronze bearings. Standard external coating is green enamel. White epoxy, coal tar epoxy and inorganic zinc primer are available upon special request.

HOW TO ORDER

2" to 12" (50 mm to 300 mm)

XXXXX Base Part Number	X Case Material	X Gear Material	X Actuation	X Valve Size	X Configuration
	Gray Iron 2	Ductile Iron 1	Crank 1 Handwheel 3 Chainwheel 5 Square Nut 6 None 9	2" to 4" (50 mm to 100 mm) 1 5" and 6" (125 mm and 150 mm) 5 8" (200 mm) 7 10" (250 mm) 8 12" (300 mm) 9	Standard 2

Description	2" to 4" (50 mm to 100 mm)	5" to 6" (125 mm to 150 mm)	8" (200 mm)	10" (250 mm)	12" (300 mm)
Operator Base No.	22622	22622	22623	22623	22623
Additional Information					
Chain Suffix = Length in ft*	4462-XXX	4462-XXX	4462-XXX	4462-XXX	4462-XXX
Weight lb (kg) with Handwheel	7.8 (3.5)	7.8 (3.5)	17.2 (7.8)	17.2 (7.8)	18.6 (8.4)

14" to 36" (350 mm to 900 mm)

XXXXX Base Part Number	X Gear Operator Assembly Part Number
	Gear Operator Less Actuation 09 Gear Operator with Handwheel 03 Gear Operator with Chainwheel 05 Gear Operator with Square Nut 06

Description	14" (350 mm)	16" (400 mm)	18" to 20" (450 mm to 500 mm)	24" (600 mm)	30" (750 mm)	36" (900 mm)
Operator Base No.	2060229	2060230	2060231	2060232	2060332	2060334
Additional Information						
Chain Suffix = Length in ft*	4462-XXX	4463-XXX	4463-XXX	19932-XXX	4463-XXX	19932-XXX
Weight (lb (kg) with handwheel)	19.0 (8.6)	22.0 (10.0)	33.0 (15.0)	43.0 (19.5)	107.0 (48.5)	137.0 (62.1)

Valve Size	in.	(mm)	Gear Ratio	Turns/90 Degree Rotation	Maximum Input Torque
	2 to 6	(50 to 150)	30:1	7-1/2	46 ft-lb
	8 to 12	(200 to 300)	48:1	12	65 ft-lb
	14 to 16	(350 to 400)	48:1	12	65 ft-lb
	18 to 20	(450 to 500)	57:1	14-1/4	98 ft-lb
	24	(600)	60:1	15	164 ft-lb
	30	(750)	316:1	79	104 ft-lb
	36	(900)	240:1	60	174 ft-lb

(Example: 6" (150 mm) with Handwheel – 22622-21352)

* Chain length (xxx) = 000 to 999 ft (chain ordered separately).

WORM GEAR OPERATORS (CONT.)

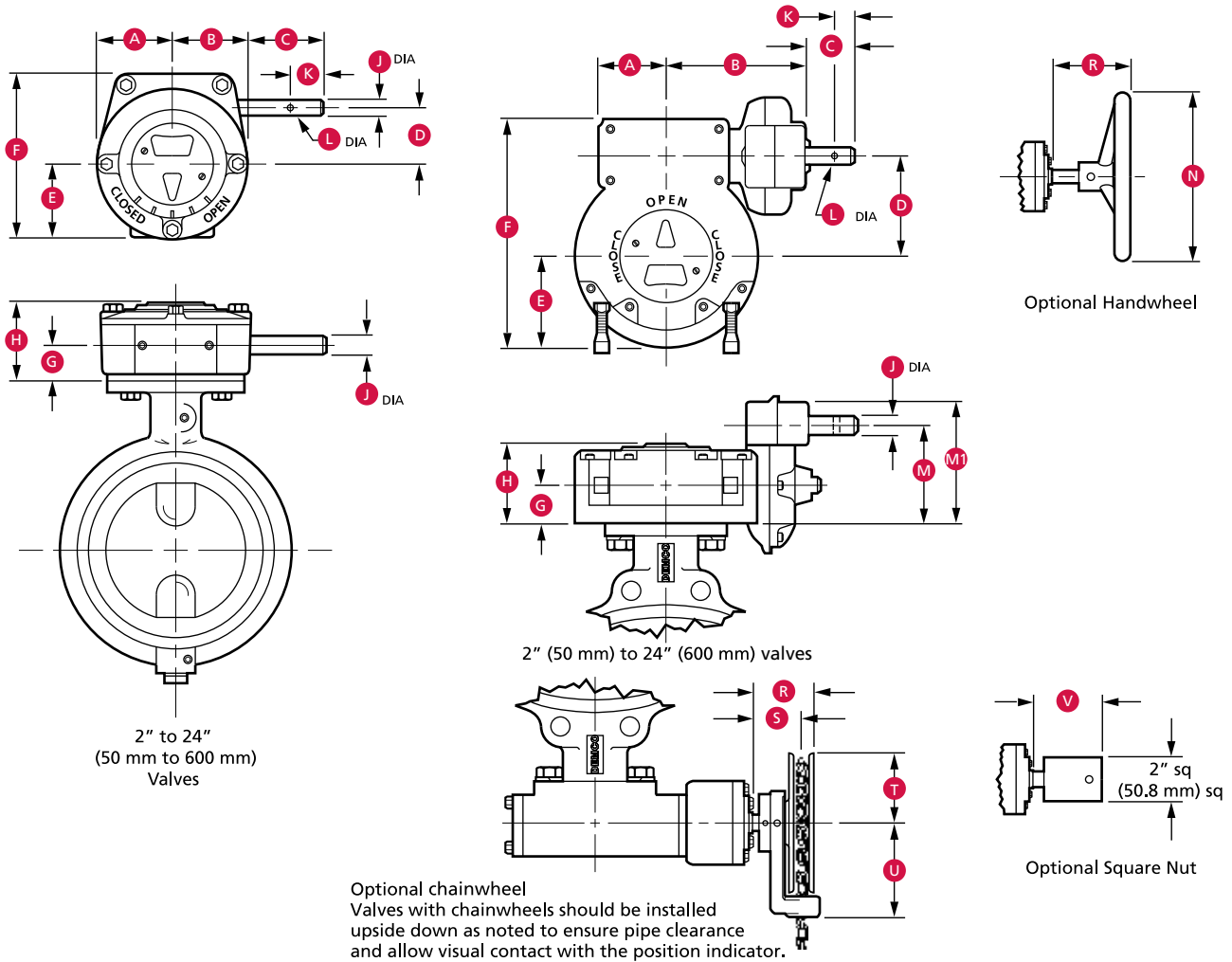

Dimensional Data

Size in.	A	B	C	D	E	F	G	H	J	K	L	M	M1	N	P	R	S	T	U	V
2 to 6	1.80	1.80	3.80	1.64	1.59	4.97	0.90	2.30	0.623	1.00	0.19	-	-	4.80	6	4.80	4.10	3.50	4.80	4.60
8 to 10	2.88	2.88	3.38	2.50	2.88	6.50	1.38	3.00	0.623	1.00	0.19	-	-	4.32	6	4.32	3.72	3.50	4.80	4.12
12	2.88	2.88	3.38	2.50	2.88	6.50	1.38	3.00	0.623	1.00	0.19	-	-	5.02	8	4.32	3.72	3.50	4.80	4.12
14	2.88	2.88	5.12	2.50	2.88	6.50	1.38	3.00	0.623	1.25	0.19	-	-	6.56	12	5.88	5.25	5.81	5.75	5.69
16	2.88	2.88	5.88	2.50	2.88	6.50	1.38	3.00	0.623	1.25	0.25	-	-	11.00	18	7.69	6.38	9.12	8.69	6.75
18 to 20	3.12	3.12	7.12	3.00	3.12	7.69	1.50	3.25	1.000	1.25	0.25	-	-	11.25	18	8.94	7.63	9.12	8.69	8.00
24	3.44	3.44	5.28	3.63	3.25	8.38	1.63	3.56	1.000	1.25	0.38	-	-	10.91	24	7.59	5.91	11.00	12.25	6.16
30	4.56	8.88	4.52	4.63	4.63	11.08	2.00	4.44	1.000	1.25	0.39	6.00	7.38	8.65	18	7.59	6.28	9.12	8.69	5.41
36	5.88	9.12	4.56	6.25	5.88	14.50	2.31	5.00	1.000	1.25	0.39	6.36	8.00	10.19	24	8.13	6.44	11.00	12.25	5.44
Size mm																				
50 to 150	46	46	97	42	40	126	23	58	16	25	4.8	-	-	122	152	122	104	89	122	117
200 to 250	73	73	86	64	73	165	35	76	16	25	4.8	-	-	110	152	110	94	89	122	105
300	73	73	86	64	73	165	35	76	16	25	4.8	-	-	128	203	110	94	89	122	105
350	73	73	130	64	73	165	35	76	16	32	4.8	-	-	167	305	149	133	148	146	145
400	73	73	149	64	73	165	35	76	16	32	6.4	-	-	279	457	195	162	232	221	171
450 to 500	79	79	181	76	79	195	38	83	25	32	6.4	-	-	286	457	227	194	232	221	203
600	87	87	134	92	83	213	41	90	25	32	9.7	-	-	277	610	193	150	279	311	156
750	116	226	115	118	118	281	51	113	25	32	9.9	152	187	220	457	193	160	232	221	137
900	149	232	116	159	149	368	59	127	25	32	9.9	162	203	259	610	207	164	279	311	138

* DT-1 gear operator dimensions became standard gear operator mid-year 2000 (for old style DT-3, consult Cameron).

STEM EXTENSIONS

Fabricated from carbon steel, stem extensions are contained in a tubular housing. Lengths from 3" to 16 ft are fabricated to order. Torsional deflection of lengths greater than 16 ft require special design consideration and are available by special order only.

STEM EXTENSIONS

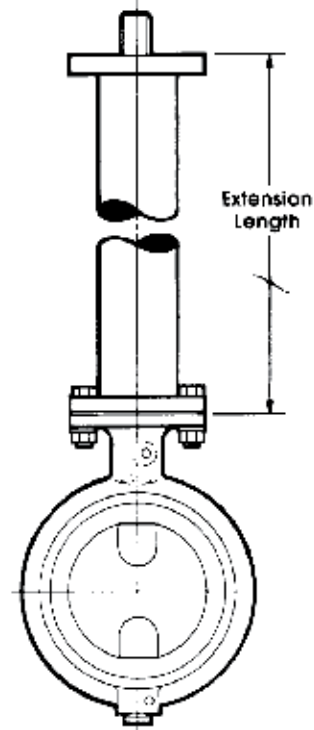

HOW TO ORDER

2" to 12" (50 mm to 300 mm)

XXXXX	XXX
Base Part Number	Length in. (mm)

14" to 24" (350 mm to 600 mm)

XXXXX	XXX00
Base Part Number	Length in. (mm)

Description	in. (mm)	2 to 4 (50 to 500)	5 to 6 (125 to 150)	8 (200)	10 (250)	12 (300)	14 (350)	16 (400)	18 to 20 (450 to 500)	24 (600)
Carbon Steel		23318	23319	23320	23321	23322	24529	24530	24531	24532

* Note: Consult Cameron for 30" (750 mm) and 36" (900 mm) valve stem extensions.

GENERAL TECHNICAL INFORMATION

Pressure Rating

Three drop-tight pressure ratings are offered for DEMCO butterfly valves. Normally, 200-psi shutoff is used in butterfly applications. However, 285-psi shutoff is optionally available for higher pressure applications. For smaller actuator sizing, 50-psi valves offer reduced torque.

For reduced torque, throttling valves, which do not provide drop-tight closure, are available.

Vacuum Rating

DEMCO butterfly valves will seal against 10 microns of vacuum (29.9 inHg). For reduced torque and extended seat life, 50-psi discs are recommended for the dry service conditions found in many vacuum applications.

End-of-Line Service

Lug body valves can be used in end-of-line service, with downstream piping removed. Only weld neck or socket flanges can be used for this service. Since upstream pressure is excluded between the flange and the seat face by the exclusive DEMCO flange seal, there is no effective force to slide the seat downstream. DEMCO lug butterfly valves are recommended for liquid service up to 200 psi with downstream piping removed.

Lug body valves are recommended for the isolation of pumps, control devices or other system components that may need to be removed for repair or replacement.

Lug valves also are suitable for installation at points from which piping expansions may proceed. Such valves normally are blanked with blind flanges to protect the exposed seats until new piping is attached.

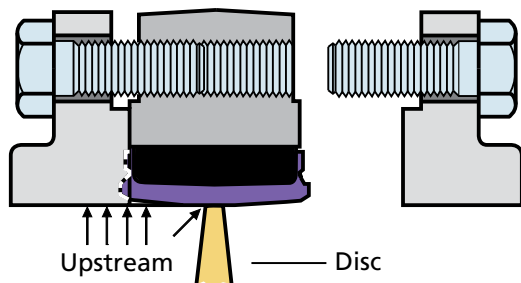

Lug Valve Connection with Downstream Flange Removed

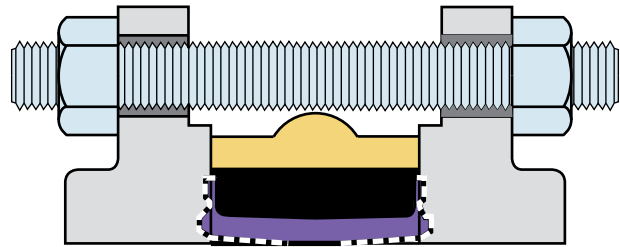

Wafer Valve Connection

Marking

Each valve is positively identified by marking and tagging per MSS-SP-25.

Actuation

Positive latch handles, worm gear operators and automatic actuators are available and interchangeable on the DEMCO valve.

The DEMCO top flange is dimensionally compatible with other competitive butterfly valves. With the optional "utility top" stem, the DEMCO valve interchanges directly with competitive valves, allowing valve replacement without the need for new actuation.

Installation and Maintenance

DEMCO butterfly valves are bi-directional, with identical flow way from either face. To install, simply close the valve, insert between flanges and make up with studs or capscrews. No regular maintenance or lubrication is ever required. Disassembly for inspection or replacement of parts is simple.

Open the valve, remove handle or actuator, remove tangential pins, pull out the stems, and push the disc and seat out of the body. Reassemble in reverse order, with a small amount of general purpose non-hydrocarbon based lubricant on the outside of stems, seat and disc flats.

Steel or cast iron flanges of either raised or flat-faced type are suitable for use with DEMCO butterfly valves. Plastic flanges are subject to damage at installation by over-tightening the bolting and may deflect or cup, resulting in flange leaks. Refer proposed plastic flange installations to Cameron's DEMCO brand quotations department for review and recommendation.

Throttling discs with no seat interference do not provide a stem seal. Stem O-rings are provided for this application. Flange gaskets assist the O-rings in 2" to 12" (50 mm to 300 mm) valves, and must be used only with throttling discs.

This nomograph gives corresponding values for the parameters of flow rate, valve size, disc angle and pressure drop of DEMCO butterfly valves in 1.0 specific gravity water service at 68° F (20° C).

The lower right-hand corner of the graph with the heavy line border represents line velocities below 15 ft/sec and normally is used for valve sizing in liquid applications.

Butterfly valves are economical throttling devices. Reliable throttling can be attained at disc openings from 25 to 70 degrees.

Sample Computation for Water

Water, with specific gravity of 1.0 and flow rate of 1200 gal/min, to 6" (160 mm) butterfly valve.

Required: Pressure drop at full and 75-degree disc openings. Project horizontally from 1200 gal/min to 6" (150 mm) valve curve. Project vertically upward to fully open valve curve, then horizontally to read 0.35 psi pressure drop. Continue upward projection to intersect 75-degree opening curve, then horizontally to read 0.8 psi pressure drop.

Sample Computation for Air

Air, with density of 0.217 lb/cf, flow rate of 40,000 cf/hr, to 5" (125 mm) butterfly valve.

Required: Pressure drop through fully open valve. Disregarding change in gas condition by pressure drop across valve, proceed from 40,000 cf/hr, as in liquid computation, to read 15 psi pressure drop. Convert pressure drop from water to air by multiplying this value times the ratio of air-to-water densities:

$$15 \text{ psi} \times \frac{0.217}{62.4} = 0.052 \text{ psi}$$

To determine pressure drop for any fluid, multiply value obtained from the nomograph by the quotient of the fluid density, in lb/cf, divided by 62.4.

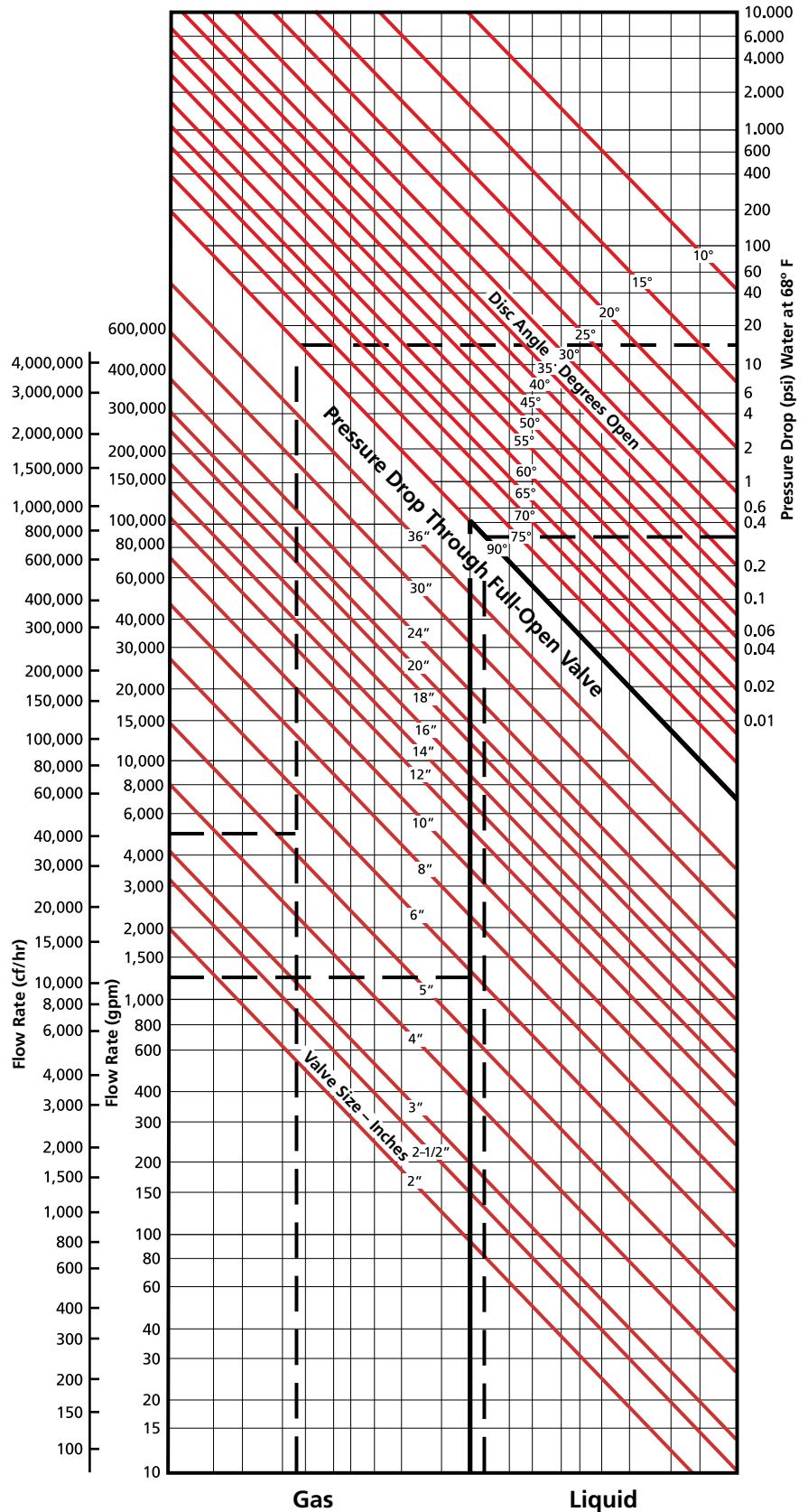

GENERAL TECHNICAL INFORMATION (CONT.)

General Dimensions 2" to 20" (50 mm to 500 mm)

Dimensions	Valve Size in. (mm)	2 (50)	2-1/2 (65)	3 (80)	4 (100)	5 (125)	6 (150)	8 (200)	10 (250)	12 (300)	14 (350)	16 (400)	18 (450)	20 (500)
A – Schedule 40 Flange ID*	(Except Slip-On)	2.07 (53)	2.47 (63)	3.07 (78)	4.03 (102)	5.05 (128)	6.07 (154)	7.98 (203)	10.02 (255)	12.00 (305)	13.25 (337)	15.25 (387)	17.25 (438)	19.25 (489)
	(Slip-On)	2.44 (62)	2.94 (75)	3.57 (91)	4.57 (116)	5.66 (144)	6.72 (171)	8.72 (221)	10.88 (276)	12.88 (327)	14.14 (359)	16.16 (410)	18.18 (462)	20.20 (513)
B – Seal Diameter		2.65 (67)	3.15 (80)	3.78 (96)	4.78 (121)	5.84 (148)	7.03 (179)	8.96 (228)	11.09 (282)	13.09 (332)	14.14 (359)	16.16 (410)	18.18 (462)	20.20 (513)
C – Raised Face Diameter		3.62 (92)	4.12 (105)	5.00 (127)	6.18 (157)	7.31 (186)	8.50 (216)	10.62 (270)	12.75 (324)	15.00 (381)	16.25 (413)	18.50 (470)	21.00 (533)	23.00 (584)
D – Valve Body Diameter		4.12 (105)	4.87 (124)	5.37 (136)	6.87 (174)	7.75 (197)	8.75 (222)	11.00 (279)	13.37 (340)	16.12 (409)	17.20 (437)	19.27 (489)	21.43 (544)	23.60 (599)
E – Seat OD		3.12 (79)	3.62 (92)	4.25 (108)	5.25 (133)	6.31 (160)	7.46 (189)	9.43 (240)	11.56 (294)	13.56 (344)	15.14 (385)	17.04 (433)	19.06 (484)	21.08 (535)
F – End-to-End	Threaded ASME Socket and Slip-On	3-3/4	4-1/8	4-1/4	4-3/4	5-1/8	5-3/8	6-1/16	6-5/8	7-5/8	7-1/2	9	9-13/16	10-11/16
	Weld End ASME Grooved	6-3/4	7-3/8	7-3/8	8-1/8	9-1/4	9-1/4	10-9/16	10-3/4	12-1/4	13	14	15-7/16	16-5/16
G – Seat ID		2-1/4	2-13/16	3-5/16	4-3/16	5-1/16	6-1/16	7-15/16	10	11-15/16	13-5/32	15-7/32	17-5/32	19-5/32
H – Disc Chord**	Resilient Seated Valves	1.467 (37)	2.144 (54)	2.743 (70)	3.601 (91)	4.582 (116)	5.624 (142.8)	7.428 (189)	9.382 (238)	11.35 (288)	12.86 (327)	14.72 (374)	16.61 (422)	18.53 (471)
J – Outside-to-Outside	ASME 150	3.25 (83)	3.62 (92)	3.75 (95)	4.00 (102)	4.12 (105)	4.25 (108)	4.81 (122)	5.12 (130)	5.75 (146)	5.75 (146)	6.87 (174)	7.56 (192)	8.31 (211)
Throughput Area	Resilient Seated – sq in.	2.33	3.92	5.93	10.01	14.98	22.09	39.43	61.52	89.54	111.2	150.5	186.1	
	% Schedule 40 Pipe	70%	82%	80%	79%	73%	76%	79%	78%	80%	82%	85%	83%	87%
Number of Studs		4	4	4	8	8	8	8	12	12	12	16	16	20
Number of Capscrews		8	8	8	16	16	16	16	24	24	24	32	32	40
Size of Studs or Capscrews – Threads per in.		5/8 - 11	5/8 - 11	5/8 - 11	5/8 - 11	3/4 - 10	3/4 - 10	3/4 - 10	7/8 - 9	7/8 - 9	1 - 8	1 - 8	1-1/8 - 7	1-1/8 - 7
Length of Studs (in.)		5	5-1/2	5-1/2	5-3/4	6-1/2	6-1/2	7	7-1/2	8-1/4	8-1/4	10	10-1/2	11-3/4
Length of Capscrews (in.)		1-1/2	1-1/2	1-3/4	1-3/4	2	2-1/4	2-1/4	2-1/2	2-1/2	3-1/4	3-1/2	4	-

* DEMCO butterfly valves are designed to seal without flange gaskets against flange faces with IDs between slip-on flange bore and schedule 40 weld neck flange bore.

** 2" to 12" (50 mm to 300 mm) disc will open into schedule 80 pipe ID.

General Dimensions 24" to 36" (600 mm to 900 mm)

Dimensions	Valve Size in. (mm)	24 (600)	30 (750)	36 (900)
A – Standard Flange ID	(Except Slip-On)	23.25 (591)	29.25 (743)	35.25 (895)
B – Seal Diameter		24.25 (616)	30.00 (762)	35.94 (913)
C – Raised Face Diameter		27.25 (692)	-	-
D – Valve Body Diameter		28.23 (717)	34.05 (865)	40.49 (1028)
E – Seat OD		25.49 (647)	31.47 (799)	37.63 (956)
F – End-to-End Weld End	ASME	18.00 (457)	16.75 (425)	18.63 (473)
G – Seat ID		23-1/4	29-5/16	35-5/16
H – Disc Chord		22.57 (573)	28.67 (728)	34.70 (881)
J – Outside-to-Outside	ASME	9.75 (248)	10.75 (273)	12.63 (321)
Number of Studs		20	*	**
Number of Capscrews		40	56	64
Size of Capscrews – Threads per in.		1-1/4 - 7	1-1/4 - 7	1-1/2 - 6
Length of Studs (in.)		12-1/2	*	**
Length of Capscrews (in.)		4	5	***
Throughput Area	sq in. % std. pipe	352.4 88%	546 81%	800 82%

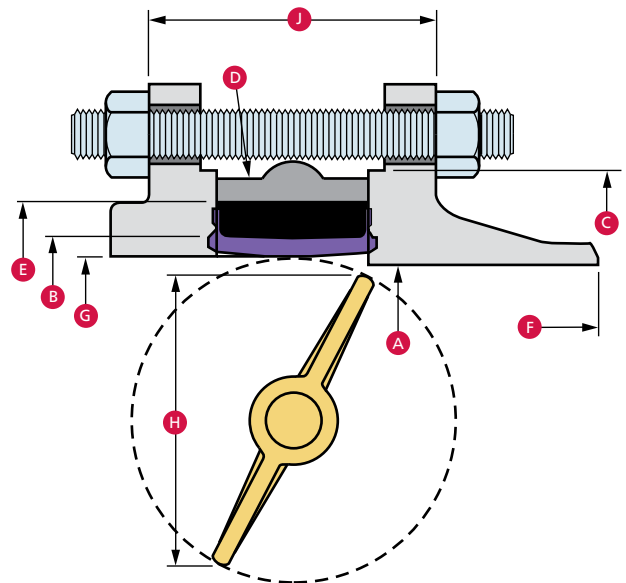

* 24 studs: 1-1/4" - 7" x 15-1/2"; Eight capscrews: 1-1/4" - 7" x 5"

** 28 studs: 1-1/2" - 6" x 18-1/2"; Eight capscrews: 1-1/2" - 6" x 5-1/2"

*** 56 screws: 1-1/2" - 6" x 6"; Eight screws: 1-1/2" - 6" x 5-1/2"

• Dimensions are for ASME Class 150 Series A flanges or MSS-SP-44 flanges. Consult Cameron for ASME Class 125 flanges.

Flow Coefficients (C_v)

Degree Open	Valve Size in. (mm)															
	2 (50)	2-1/2 (65)	3 (80)	4 (100)	5 (125)	6 (150)	8 (200)	10 (250)	12 (300)	14 (350)	16 (400)	18 (450)	20 (500)	24 (600)	30 (750)	36 (900)
90°	145	225	325	590	1125	1950	3250	5000	7500	10,000	13,600	18,000	22,600	30,000	47,000	70,000
80°	115	175	260	510	1000	1650	2725	4300	6050	8100	11,500	14,300	18,000	25,000	38,000	60,000
75°	95	135	215	410	830	1350	2200	3600	5000	6700	9500	12,100	15,000	21,000	31,500	48,000
70°	70	105	160	305	625	1030	1750	2750	4050	5100	7100	9200	11,500	16,500	25,500	39,500
60°	53	83	125	235	490	800	1300	2150	3100	4100	5100	7100	8700	11,750	18,000	28,000
50°	27	42	63	120	250	410	700	1150	1600	2200	2650	3700	4600	6100	9700	15,000
40°	17	26	38	73	155	250	420	670	1000	1300	1700	2300	2800	3800	6000	9200
30°	9	15	22	42	88	145	250	390	550	750	900	1250	1600	2200	3500	5300
25°	6	10	15	28	60	98	170	260	380	500	650	900	1125	1500	2300	3500

C_v values, given above, may be employed in the formula:

$$Q = C_v \times \sqrt{\frac{\Delta P \times 62.4}{D}}$$

Where:

Q = gal/min of flow through the valve

ΔP = psi pressure drop across the valve

D = density of fluids in lb/cu ft

Pressure drop is computed by rearranging the formula to the following:

$$\Delta P = \frac{Q^2 \times D}{C_v^2 \times 62.4}$$

Sample Computations

What is the flow rate of water at ambient temperature through a 4" (100 mm) butterfly valve that is 70 degrees open when the pressure drop across the valve is 0.5 psi? (Density of water at 68° F is 62.4 lb/cu ft.)

$$\begin{aligned} Q &= C_v \times \sqrt{\frac{\Delta P \times 62.4}{D}} \\ &= 305 \times \sqrt{\frac{0.5 \times 62.4}{D}} \\ &= 305 \times 0.707 \\ Q &= 215.6 \text{ gal/min} \end{aligned}$$

What is the pressure drop across an 8" (200 mm) butterfly valve that is fully open, flowing 2000 gal/min of solvent with a density of 55 lb/cu ft?

$$\begin{aligned} \Delta P &= \frac{Q^2 \times D}{C_v^2 \times 62.4} \\ &= \frac{(2000)^2 \times 55}{(3250)^2 \times 62.4} \\ \Delta P &= 0.33 \text{ psi} \end{aligned}$$

Water Hammer

Water hammer is a series of shocks in a piping system caused by rapidly stopping the flow of fluid in that system.

Although it is difficult to measure pressure spikes caused by water hammer shock with ordinary equipment, maximum obtainable pressures caused by instantaneous valve closure can be approximated by the following formula:

Pressure (max.) = interrupted velocity (fps) x 58 psi/ft/sec

In other words, pressure increases 58 psi for each ft/sec of interrupted pipeline velocity.

A pipe carrying fluid at a velocity of 15 ft/sec velocity will have an instantaneous pressure increase of 870 psi under rapid closure conditions.

The effects of water hammer are seen in a butterfly valve as bent disc and stems, a broken body or both.

Water hammer can be reduced or eliminated by slowing valve closure time in accordance with the following formula:

$$\text{time seconds} = \frac{0.14Q}{S(P)}$$

Where:

Q = flow in gal/min

S = upstream pipe size in sq ft

P = pressure rating of the valve in psi

Generally, a closing time of six to eight seconds is sufficient to eliminate water hammer.

GENERAL TECHNICAL INFORMATION (CONT.)

Cavitation Data

Liquid flow is accelerated as it passes through a valve in such a manner that pressure is decreased below the vapor pressure and bubbles form. Immediately downstream of the valve, velocity decreases while pressure increases and the bubbles collapse, causing possible mechanical damage to the valve and piping. This is called cavitation. Cavitation often can be identified by the noise of the collapsing bubbles, which sounds like gravel flowing in the pipe.

Generally, butterfly valves operate with high-flow capacities and at low-pressure differentials and are not particularly susceptible to cavitation.

When butterfly valves are used as control valves, one can ensure that cavitation will not occur by applying the following simplified formula:

$$\Delta P_{\max} = K_c (P_1 - P_v)$$

Where:

ΔP_{\max} = differential pressure across the valve

K_c = cavitation constant
(approximately 0.35 for butterfly valves)

P_1 = inlet pressure (psia)

P_v = vapor pressure of the flowing liquid (psia)

Example:

What is the maximum pressure drop possible through a butterfly valve at 100 psig inlet pressure with water at 68° F (0.339 psia vapor pressure)?

$$\Delta P_{\max} = K_c (P_1 - P_v)$$

Under the above conditions, it is possible to take a 40.03-psi pressure drop across the valve before cavitation will begin.

TORQUE DATA

The torque (turning effort) required to operate a given butterfly valve is determined by two factors: friction of the disc and the seat. The interference and dynamic forces of flow through the valve tend to open or close the valve. The actuator torque output must meet or exceed the maximum torque requirement of the valve. Normal wet opening torque requirements due to interference are tabulated below. Dry service will increase opening torque significantly. Consult Cameron for dry service torque requirements.

The disc of a butterfly valve, in partially opened condition, is subject to lift forces from passage of fluid over its surfaces. This effect is analogous to an airplane wing and results in an unbalanced turning force on the disc. The dynamic torque is proportional to the pressure drop through the valve and may become significant in some applications.

Dynamic torque typically is at a maximum when the disk opening is about 70 degrees. Under high differential pressure conditions, such torque may exceed the design strength of stems, connections or actuators. The curves at right may be used to calculate dynamic torque for DEMCO butterfly valves and should be consulted in any case where high differential pressure may occur during valve operation.

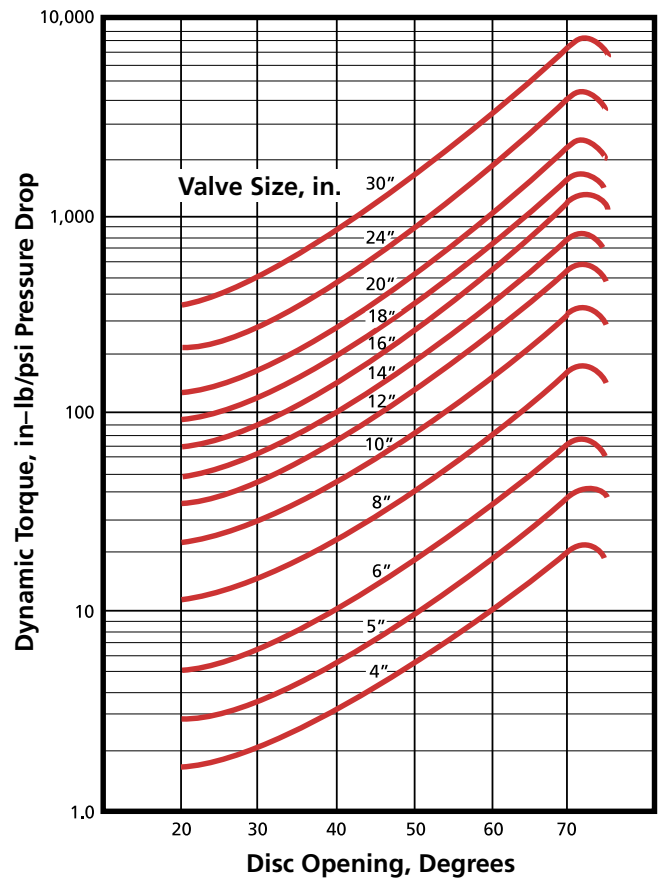

Butterfly Valve Torques (Except Series NEI-T)** – Normal Wet Opening – in-lb

Valve Size	in. (mm)	2 (50)	2-1/2 (65)	3 (80)	4 (100)	5 (125)	6 (150)	8 (200)	10 (250)	12 (300)	14 (350)	16 (400)	18 (450)	20 (500)	24 (600)	30 (750)	36 (900)
285 psi Shutoff		225	326	510	765	1190	1530	2550	4125	7000	-	-	-	-	-	-	-
200 psi Shutoff		132	192	300	450	700	900	1500	2650	4500	-	-	-	-	-	-	-
150 psi Shutoff		-	-	-	-	-	-	-	-	-	7740	10,280	12,600	15,600	30,000	50,000	67,500
50 psi Shutoff		108	108	192	264	450	550	1000	1800	3000	4500	6500	8400	10,800	20,000	30,000	50,000
Throttling*		72	72	90	108	144	180	350	700	1160	1660	2800	3400	5000	8400	-	-

Butterfly Valve Torques (Except Series NEI-T)** – Three-Way Assemblies – in-lb

Valve Size	in. (mm)	2 (50)	2-1/2 (65)	3 (80)	4 (100)	5 (125)	6 (150)	8 (200)	10 (250)	12 (300)	14 (350)	16 (400)	18 (450)	20 (500)	24 (600)	30 (750)	36 (900)
285 psi Shutoff		338	489	765	1148	1785	2295	3825	6188	10,500	-	-	-	-	-	-	-
200 psi Shutoff		198	288	450	675	1050	1350	2250	3975	6750	-	-	-	-	-	-	-
150 psi Shutoff		-	-	-	-	-	-	-	-	-	11,610	15,420	18,900	23,400	45,000	-	-
50 psi Shutoff		162	162	288	396	675	825	1500	2700	4500	6750	9750	12,600	16,200	30,000	-	-
Throttling*		144	144	180	216	288	360	700	1400	2320	3320	5600	6800	10,000	16,800	-	-

* When line velocity exceeds 15 ft/sec, dynamic torque exceeds opening torque.

** Consult Cameron for the torque requirement of the Series NEI-T butterfly valve.

STANDARD MATERIAL DATA

Bodies

Description		NE-C	NF-C 14" to 24"	NF-C 30" and 36"	NE-I	NE-D	NE-I Sanitary	NEI-T
See page 10 for Assembly Part Number								
Ductile Iron	A395 (60-40-18) * ENC-Coated	Lug	Lug	Wafer/Lug	Wafer Wafer	Wafer	Wafer/Lug	Wafer/Lug
Gray Iron	A48 (Class 20) A126 (Class B)	Wafer	Wafer					Wafer
Bronze	B148 (952)		C/F		Wafer/Lug		Wafer/Lug	Wafer/Lug
Steel	A216 (WCB) *		Lug		Wafer/Lug			Wafer/Lug
Stainless Steel	A351 (CF8M)				Wafer/Lug		Wafer/Lug	Wafer/Lug
Aluminum	B26				Wafer		Wafer	Wafer
Discs								
Ductile Iron/ Nickel-Plated	A536 (65-45-12)	•	•	•	•	•		
Ductile Iron/ PVF-Coated	A536 (65-45-12)	•	•		•	•		
Aluminum	B148 (954)	•			•	•		
Bronze	B148 (955)		•	•				
316 SS	A743 (CF8M)	•	•	•	•	•	•	•
Monel **	A494 (M30C)	•	•		•	•		
Alloy 20, 29 Ni-20 Cr	A743 (CN-7M)	•			•	•		•
Hastelloy C **		•						
61 Ni-17 Mo-17 Cr	A494 (CW-2M)	•			•	•		•
Stems								
416 SS	QQ-S-764-B	•	•	•	•	•		•
316 SS	AMS 5648 B	•	•	•	•	•	•	•
17-4 PH SS	AMS 5643	•	•		•	•	•	•
Monel **	B164 (Class A)	•	•	•	•	•		

* Conforms to USCG Marine requirements, as outlined in 46 C.F.R., part 56.

** See material trademark on page 40. Consult Cameron for special material requirements.

Seats vary. See pages 9, 10 and 11 for seat material description and part number scheme for available options for different valve series.

Buna-N is a general purpose elastomer compounded for maximum hydrocarbon or petroleum resistance. 0° F to 180° F (-18° C to 82° C). Same as Nitrile, Hycar* and NBR.

General Service EPDM is recommended for water service. Resistance to saturated steam up to 275° F (135° C) is superior. EPDM is suitable in alkaline solutions. EPDM is not suitable for oil or hydrocarbons. Peroxide-cured 20° F to 275° F (-6° C to 135° C).

Food Grade EPDM is formulated in compliance with FDA guidelines published in the Code of Federal Regulations, Title 21, paragraph 177.2600. This material is suitable for food service, except milk and edible oils. Peroxide-cured 20° F to 275° F (-6° C to 135° C).

Sulfur-cured -30° F to 225° F (-34° C to 107° C). Same as EPDM and Nordel*.

Black Neoprene complies with FDA guidelines and is principally recommended for food and beverage service. It is resistant to vegetable oils, brine and oxygen. 0° F to 180° F (-18° C to 82° C). Same as Polychloroprene and CPE.

White Neoprene complies with FDA guidelines and offers chemical resistance comparable to black neoprene, but it uses fillers other than carbon black to provide white coloration. Physical properties are not as good as black neoprene, and white neoprene should be used only when black cannot be tolerated. Storage should be under low light conditions to prevent discoloration. 0° F to 180° F (-18° C to 82° C).

Hypalon* is compounded for chemical resistance and is superior in acids and hydrocarbons. 0° F to 180° F (-18° C to 82° C). Same as CP.

FKM is superior at elevated temperatures and in harsh chemical environments. FKM is not suitable for hot water or steam. 20° F to 300° F (-6° C to 149° C). Same as Fluoroelastomer.

Natural Rubber generally is superior to other elastomers in abrasion resistance and is recommended for dry material handling. Use in oils and solvents is not recommended. -30° F to 150° F (-34° C to 65° C).

Fluorosteam seats offer heat and chemical resistance to hydrocarbons and hot water or saturated steam. Maximum temperature capability is dependent on fluid resistance, pressure and flow rates. 20° F to 275° F (-6° C to 135° C).

ETM-30230 is compounded to combine many of the better media properties of Buna-N, EPDM or neoprene for service in hydrocarbons, gasoline, solvents, animal oils and vegetable oils with a temperature range of -30° F to 230° F (-34° C to 110° C). Abrasion resistance is equal to Buna-N. Resistance to H₂S and CO₂ are superior to Buna-N. -30° F to 230° F (-34° C to 110° C).

NEI-T Teflon* SEAT is EPDM elastomer bonded to a virgin TFE covering. This provides an inert, aseptic non-stick surface, which is excellent for sanitary food service applications. 0° F to 50° F (-18° C to 10° C).

Other seat elastomers are available for special applications. Consult Cameron.

* See material trademark note on page 40.

MATERIAL SELECTION GUIDE

The following application is designed for use in determining the available material most likely to give satisfactory service and is not meant to imply any type warranty. However, certain factors such as temperature, concentration and combinations of chemicals may affect the fluid resistance of any material. In questionable applications, testing is always the most positive way to determine suitability. Some materials are available in certain valve sizes and series only.

Rating Interpretation	Stem and Disc								Seat						
	Nickel-Plated Ductile Iron	416 SS	316 SS	Monel *	Aluminum Bronze	Alloy 20	Hastelloy C*	PVF	Buna-N	Neoprene	Hypalon*	FKM	EPDM	Natural Rubber	ETM-30230
Acetaldehyde	U	U	E	E	U	E	E	G	G	F	U	F	E	U	-
Acetic Acid – Crude	U	U	E	F	U	E	E	-	G	E	E	-	-	-	-
Acetic Acid – Pure	U	U	E	F	F	E	E	E	G	E	E	-	-	-	-
Acetic Acid – 10%	U	U	E	F	U	E	E	-	G	E	E	-	-	-	G
Acetic Acid – 80%	U	U	E	F	U	E	E	-	G	E	E	-	-	-	-
Acetic Acid – Anhydrite	U	U	E	F	U	E	E	U	U	E	E	U	F	F	U
Acetone	G	G	E	E	E	E	E	U	U	U	U	U	E	F	U
Acetophenone	U	U	G	E	U	-	-	F	U	-	-	-	E	-	U
Acetylene	G	E	E	E	E	E	U	-	G	F	F	E	-	F	G
Acrylonitrile	G	G	E	E	E	-	-	U	U	F	F	U	U	U	-
Air (Dry)	E	E	E	E	E	-	-	-	E	E	E	E	G	G	-
Alcohol – Amyl	F	G	E	E	E	E	-	E	F	F	G	E	E	G	E
Alcohol – Butyl	F	G	E	E	E	E	E	E	F	G	G	E	F	F	-
Alcohol – Ethyl	U	-	E	E	E	E	E	E	G	G	G	G	G	G	E
Alcohol – Methyl	U	-	E	E	E	E	E	-	F	E	E	F	E	G	-
Alum – Ammonium	U	-	G	-	-	-	-	-	G	G	F	E	G	-	-
Alum – Chrome	U	-	G	-	-	-	-	-	G	G	G	G	-	F	-
Alum-Potassium	U	G	-	-	G	-	-	-	G	G	F	E	G	-	-
Alumina	G	G	G	G	G	E	E	-	E	F	G	G	E	E	-
Aluminum Chloride	U	U	F	G	U	E	-	E	G	G	G	E	E	G	G
Aluminum Fluoride	U	-	G	G	-	E	-	E	G	G	G	G	E	G	G
Aluminum Hydroxide	U	-	G	G	G	-	-	E	G	G	-	G	G	-	-
Aluminum Sulfate	U	G	G	-	U	G	E	-	E	E	E	E	E	E	-
Amines	U	F	E	G	-	E	U	-	U	U	U	U	F	-	-
Ammonia, Anhydrous	F	-	E	E	U	-	E	E	G	G	U	U	G	U	U
Ammonia Solutions	F	G	E	G	U	E	E	-	G	G	U	U	G	U	U
Ammonium Chloride 50% 180° F (82° C)	U	F	G	G	U	E	E	E	E	E	E	E	E	E	G
Ammonium Hydroxide	F	G	E	F	U	E	E	E	U	E	E	G	E	U	F
Ammonium Nitrate 5% 60° F (16° C)	F	G	E	U	U	E	E	E	E	E	G	E	E	G	G
Ammonium Phosphate	U	G	E	G	U	E	E	E	E	E	E	E	E	G	G
Ammonium Sulfate 90% 180° F (82° C)	U	F	G	G	U	G	G	E	E	E	E	E	E	G	-
Amyl Acetate	F	G	E	G	G	E	U	F	U	U	U	U	G	U	U
Amyl Chloride	F	G	E	G	E	E	E	E	U	U	U	-	U	U	-
Aniline 90% 70° F (21° C)	F	G	G	G	U	E	E	F	U	U	U	F	F	U	U
Aniline Dyes	F	G	E	E	F	E	E	-	U	F	F	G	-	-	U
Antimony Chloride	U	-	-	G	-	-	E	-	G	G	G	E	-	-	-
Arsenic Acid	U	G	G	G	U	E	-	E	E	E	E	E	G	G	G
ASTM Oil #1	F	E	E	E	E	E	E	-	E	G	G	E	U	U	-
ASTM Oil #3	F	E	E	E	E	E	E	-	E	U	U	E	U	U	-
ASTM Ref. Fuel A	F	E	E	E	G	E	E	-	E	G	G	E	U	U	E
ASTM Ref. Fuel B	F	E	E	E	G	E	E	-	G	F	F	E	U	U	E
ASTM Ref. Fuel C	F	E	E	E	G	E	E	-	G	F	F	E	U	U	-
Asphalt	E	E	E	E	E	E	E	-	G	-	-	E	U	U	E
Barium Carbonate 60° F (16° C)	U	-	G	G	G	-	E	E	E	E	-	-	E	-	-
Barium Chloride	U	-	G	G	F	-	E	E	E	E	E	E	E	E	E
Barium Hydroxide	F	E	E	G	U	E	-	E	E	E	E	E	E	G	E
Barium Sulfate 60° F (16° C)	U	-	E	G	G	-	-	E	E	E	-	-	E	-	E
Barium Sulfide	F	E	G	F	U	E	-	E	E	E	U	-	-	U	-

* See material trademark note on page 40.

MATERIAL SELECTION GUIDE (CONT.)

Rating Interpretation E – Excellent G – Good F – Fair U – Unsatisfactory	Stem and Disc								Seat						
	Nickel-Plated Ductile Iron	416 SS	316 SS	Monel*	Aluminum Bronze	Alloy 20	Hastelloy C*	PVF	Buna-N	Neoprene	Hypalon*	FKM	EPDM	Natural Rubber	ETM-30230
Beer (Beverage)	U	E	E	E	U	E	E	E	G	G	E	E	E	G	G
Beet Sugar Liquors	F	E	E	E	F	E	-	-	E	E	G	E	-	G	-
Benzaldehyde	F	E	E	G	E	E	-	-	U	U	U	U	E	U	U
Benzene (Benzol) 70° F (21°)	F	E	E	G	E	E	E	G	U	U	U	G	U	U	U
Benzoic Acid 5% 70° F (21°)	U	G	E	G	G	E	E	E	U	U	U	E	U	U	-
Black Sulfate Liquor	F	G	E	-	F	E	-	-	G	G	G	E	G	F	-
Bleaching Powder – Wet	U	G	G	-	U	E	-	-	G	E	F	-	-	F	-
Borax (Sodium Borate)	U	F	E	E	U	E	E	E	G	E	E	E	E	G	G
Boric Acid 5% 200° F (93° C)	U	F	E	G	F	E	E	E	E	E	E	E	E	G	G
Brine (Acid)	U	-	G	G	G	-	-	E	E	G	G	-	E	U	-
Brine – Chlorinated	-	-	U	G	G	-	-	-	-	-	-	G	G	-	-
Bromine – Gas	U	U	U	F	-	U	E	E	U	U	U	E	U	U	-
Bromine – Water	U	U	U	F	-	U	E	E	U	G	G	E	U	U	-
Butadiene	F	G	E	E	G	-	E	E	F	-	G	G	-	U	U
Butane – Butylene	G	E	E	E	E	E	E	E	G	G	G	E	U	U	G
Butyl Acetate	G	E	E	E	E	E	E	U	U	U	U	U	U	U	U
Butyric Acid 5% 70° F (21° C)	U	G	E	G	G	E	E	-	U	U	U	G	G	U	-
Calcium Bisulfite	U	G	E	U	U	G	-	E	E	E	E	E	U	U	-
Calcium Carbonate 60° F (16° C)	F	-	G	E	G	-	E	E	E	E	-	E	-	-	-
Calcium Chlorate 20% 160° F (71° C)	-	G	E	G	U	E	E	E	-	E	E	-	-	-	-
Calcium Chlorate 20% 160° F (71° C)	-	G	E	G	U	E	E	E	-	E	E	-	-	-	-
Calcium Chloride	F	G	G	G	E	G	E	E	E	E	E	-	-	-	E
Calcium Hydroxide 50% 175° F (79° C)	F	E	E	E	U	E	E	E	G	E	E	E	-	-	G
Calcium Hypochloride	-	G	G	-	-	G	-	-	U	U	E	E	-	U	F
Calcium Sulfate 90% 60° F (16° C)	F	E	E	G	E	E	-	E	F	F	-	E	-	-	-
Calgon	F	-	E	-	-	E	-	-	E	E	-	E	-	-	-
Caliche Liquor	U	-	E	-	-	E	-	-	E	E	E	E	E	E	-
Cane Sugar Liquors	F	E	E	G	E	E	-	-	E	E	-	-	-	-	G
Carbon Dioxide (Dry)	F	E	E	-	E	E	-	E	E	G	G	E	-	-	G
Carbon Disulfide	U	-	E	G	G	-	-	G	U	U	U	E	U	U	-
Carbon Tetrachloride (Dry)	U	G	G	E	G	E	-	E	U	-	-	E	-	-	F
Carbonic Acid	U	G	E	E	-	E	E	E	G	E	E	E	E	E	G
Caster Oil	G	G	E	E	G	E	E	E	G	E	E	E	G	G	G
Caustic Solutions 34% 200° F (93° C)	U	G	E	F	U	E	E	-	F	F	F	E	G	U	F
China Wood Oil (Tung)	F	-	E	E	F	E	E	-	E	E	G	E	U	U	-
Chlorine Gas – Dry 70° F (21° C)	U	F	G	G	G	G	E	E	U	U	G	E	F	U	-
Chlorobenzene 90% 70° F (21° C)	F	E	G	G	G	E	-	E	U	U	U	G	U	U	U
Chloroform 70° F (21° C)	F	G	E	E	G	E	-	E	U	U	U	E	U	U	U
Chlorosulfonic Acid 10%	U	U	G	F	G	U	E	F	U	U	U	U	U	U	-
Chocolate	-	-	-	-	-	-	-	-	E	U	-	-	-	-	-
Chromic Acid 5% 70° F (21° C)	U	G	G	F	U	E	-	E	U	U	E	E	U	U	-
Citrus Acid 5% 150° F (66° C)	U	F	E	G	F	E	E	E	E	E	E	E	E	F	E
Coconut Oil (Food)	U	U	E	G	G	E	-	E	E	F	F	E	F	U	-
Coffee (Food)	U	U	E	G	F	E	-	E	E	E	E	E	E	E	-
Copper Chromate	-	-	E	-	-	-	-	-	-	-	-	-	-	-	-
Copper Sulfate 80% 175° F (79° C)	F	G	E	F	U	E	-	E	E	E	E	E	E	E	-
Corn Syrup	-	-	E	-	-	-	-	-	-	-	-	-	E	-	-
Cottonseed Oil	G	E	E	E	E	E	E	E	E	F	G	G	F	U	G
Creosol	U	F	E	E	-	E	-	F	U	U	U	F	U	U	-
Creosote	E	E	E	E	G	E	E	-	G	U	F	E	U	U	U
Cresylic Acid	U	G	E	G	G	E	-	G	U	U	U	E	U	U	U
Crude Oil	G	G	E	E	E	E	E	-	E	-	-	E	U	U	E
Cyclohexane	F	E	E	G	G	E	-	E	U	U	U	E	U	U	-
Dextrose (Food)	U	U	E	-	-	E	-	-	E	-	-	-	-	-	-

* See material trademark note on page 40.

Rating Interpretation	Stem and Disc								Seat						
	Nickel-Plated Ductile Iron	416 SS	316 SS	Monel*	Aluminum Bronze	Alloy 20	Hastelloy C*	PVF	Buna-N	Neoprene	Hypalon*	FKM	EPDM	Natural Rubber	ETM-30230
Diacetone	U	-	E	-	E	-	-	U	U	U	U	U	E	U	-
Diamylamine	F	E	E	-	E	E	-	-	G	F	-	U	-	G	-
Dichlorethene	U	-	G	G	G	G	-	F	U	U	-	G	U	-	U
Diesel Fuels	E	E	E	E	G	E	E	E	E	F	F	E	U	F	E
Diethyl Amine	F	E	E	G	E	E	-	U	G	F	F	U	F	U	-
Dimethane Sulfide	-	-	-	-	-	-	-	-	-	-	F	U	G	-	-
Dowtherms	G	E	E	E	G	E	-	-	U	G	G	E	-	-	U
Drilling Mud	G	-	E	E	G	-	-	-	E	F	E	E	-	G	E
Ethers	U	-	G	G	G	E	E	F	U	U	U	F	F	U	-
Ethyl Acetate	F	G	E	E	G	E	E	F	U	U	U	U	G	U	U
Ethyl Chloride 5% 60° F (16° C)	F	G	E	G	E	E	E	E	E	G	G	G	G	G	G
Ethyl Glycol	G	E	E	E	E	E	E	E	E	G	E	E	E	E	-
Ethylene Dichloride	U	-	G	G	G	-	-	E	U	U	U	F	U	-	U
Ethylene Oxide	G	G	G	G	U	E	-	U	U	U	U	U	F	U	U
Ferric Chloride	U	U	U	U	U	-	U	E	E	G	G	E	E	E	G
Ferric Nitrate (pH 7+) 5% 60° F (16° C)	U	-	G	F	U	E	-	E	E	E	E	E	E	E	E
Ferric Sulfate 5% 60° F (16° C)	U	-	E	E	U	-	-	E	E	E	E	E	E	E	E
Ferrous Sulfate	F	G	G	-	U	E	-	E	E	E	-	E	E	E	-
Fluorine 70° F (21° C)	U	U	F	G	U	G	-	E	G	F	G	G	F	-	-
Fluorosilicic Acid	U	F	G	G	F	E	-	E	E	G	E	-	-	G	-
Formaldehyde 70° F (21° C)	U	G	E	G	E	E	E	G	F	-	E	E	-	F	F
Formic Acid 5% 150° F (66° C)	U	G	E	G	G	E	E	E	G	E	E	E	E	E	G
Freon 11	F	E	E	E	E	E	-	E	G	G	E	G	U	-	-
Freon 12	F	E	E	E	E	E	-	E	G	G	U	U	U	-	F
Freon 22	F	E	E	E	E	E	-	E	U	-	E	U	E	-	F
Freon 113	F	E	E	E	E	E	-	-	G	G	E	G	U	U	F
Freon 114	F	E	E	E	E	E	-	-	G	G	F	F	U	-	F
Fructose	-	-	E	-	-	-	-	-	-	-	-	-	E	-	-
Fruit Juices (Food) 70%	U	U	E	E	U	E	E	-	E	E	F	E	G	G	-
Fuel Oil	F	E	E	E	E	E	E	E	G	F	F	E	U	U	E
Furfural	F	E	E	G	G	E	E	U	U	U	U	U	F	U	U
Gallic Acid 5% 200° F (93° C)	U	-	E	G	-	E	E	F	G	G	G	E	G	E	-
Gasohol	F	G	E	-	G	-	-	E	U	-	-	G	U	-	U
Gasoline – Regular	G	E	E	E	E	E	E	E	G	-	G	E	U	U	E
Gasoline – Unleaded	F	E	E	E	E	-	-	E	U	-	-	E	U	-	G
Gelatin (Food)	U	U	E	G	G	E	-	-	E	E	E	E	E	E	E
Glucose	U	F	E	-	E	E	-	E	E	E	E	E	E	E	E
Glycerine/Glycerol 70° F (21° C)	F	E	E	G	G	E	E	E	E	E	E	E	E	E	E
Heptane	F	G	E	G	E	E	-	E	E	G	G	E	U	U	-
Hexane	F	G	E	G	E	E	-	E	E	G	G	E	U	U	E
Hydraulic Oils	F	G	E	E	E	E	-	-	G	F	E	E	U	U	G
Hydrobromic Acid 200° F (93° C)	U	U	U	U	U	U	E	E	U	U	E	E	E	E	-
Hydrochloric Acid 10% 60° F (16° C)	U	U	U	F	U	U	E	E	F	G	G	E	G	-	-
Hydrochloric Acid 20% 60° F (16° C)	U	U	U	U	U	U	E	E	F	G	G	E	-	-	-
Hydrochloric Acid 35% 60° F (16° C)	U	U	U	U	U	U	G	G	F	G	G	E	-	-	U
Hydrocyanic Acid	U	-	G	F	U	E	E	E	G	G	E	E	G	G	-
Hydrofluoric Acid 48%	U	F	U	F	U	F	E	E	U	U	E	E	-	-	-
Hydrofluoric Acid 60%	U	U	U	U	U	F	E	E	G	U	G	G	E	G	-
Hydrofluoric Acid 100%	U	U	U	U	U	F	E	E	U	U	U	F	-	-	-
Hydrofluosilicic Acid 5% 70° F (21° C)	U	G	G	G	E	G	E	G	G	G	E	E	E	E	-
Hydrogen	F	G	E	E	F	E	-	E	E	E	E	E	E	G	-
Hydrogen Peroxide 90%	U	F	G	G	U	G	E	E	U	U	G	G	F	U	G
Hydrogen Sulfide – Dry	F	F	E	G	F	G	E	E	F	-	G	G	E	G	G
Hydrogen Sulfide – Wet	F	F	G	F	F	E	-	E	-	-	G	G	G	U	F

* See material trademark note on page 40.

MATERIAL SELECTION GUIDE (CONT.)

Rating Interpretation	Stem and Disc								Seat						
	Nickel-Plated Ductile Iron	416 SS	316 SS	Monel*	Aluminum Bronze	Alloy 20	Hastelloy C*	PVF	Buna-N	Neoprene	Hypalon*	FKM	EPDM	Natural Rubber	ETM-30230
Iodine Solution	U	U	U	U	U	U	E	E	F	U	G	E	G	F	-
Iso – Octane	F	E	E	E	E	E	E	E	E	G	G	E	U	U	G
Isopropyl Alcohol	F	E	E	E	E	E	E	-	G	F	E	E	E	E	G
Isopropyl Ether	F	E	E	E	E	E	E	-	G	F	F	U	U	U	-
Kerosene	E	E	E	E	E	E	E	E	E	G	U	E	U	U	E
Lacquer Solvents	F	E	E	E	E	E	E	-	U	U	U	U	U	U	U
Lactic Acid 5% 70° F (21° C)	U	F	G	G	U	E	E	U	G	E	E	E	G	G	-
Lard Oil 70° F (21° C)	G	-	E	G	G	E	E	E	E	F	U	E	U	U	E
Lemon Oil	U	F	E	E	E	E	E	E	G	F	-	-	-	-	-
Linseed Oil	F	E	E	E	E	E	E	E	E	G	G	E	U	-	-
Lubricating Oil	E	E	E	E	E	E	E	E	E	F	G	E	U	U	E
Magnesium Chloride 4% 75° F (24° C)	F	F	G	G	F	E	E	E	E	E	E	E	E	E	E
Magnesium Hydroxide	F	E	E	G	G	E	-	E	G	E	E	E	E	G	G
Magnesium Sulfate 5% 120° F (49° C)	F	G	E	E	E	E	E	E	E	E	E	E	E	G	E
Mercuric Chloride 3% 60° F (16° C)	U	U	F	U	U	F	E	E	E	E	E	E	E	E	E
Mecuric Cyanide	U	-	E	U	U	E	E	F	G	F	F	F	G	-	F
Mercurous Nitrate (pH 7+)	U	-	G	U	U	E	E	E	F	F	-	-	-	-	-
Mercury	E	E	E	E	U	E	E	E	E	E	E	E	E	E	E
Methyl Acetate	F	G	E	-	-	E	-	-	U	U	U	U	G	U	U
Methyl Acetone	F	E	E	-	E	E	-	-	U	U	U	-	-	U	U
Methyl Cellosolve	F	E	E	E	E	E	-	E	U	U	U	U	G	U	-
Methyl Chloride	G	G	E	G	E	E	-	E	U	U	U	G	F	U	-
Methyl Ethyl Ketone (MEK)	E	E	E	-	E	E	-	U	U	U	U	U	E	U	U
Milk (Food)	U	U	E	F	U	E	E	E	E	E	-	E	U	-	-
Mineral Oil	F	-	E	E	G	E	E	E	E	G	G	E	U	U	E
Molasses (Food)	U	U	E	-	U	E	-	G	-	E	-	-	E	-	-
Naphtha	F	E	E	G	G	E	E	E	G	U	U	E	U	U	G
Naphthalene	F	E	E	G	G	E	-	E	U	U	U	E	U	U	-
Natural Gas (Methane)	G	E	E	-	E	E	-	-	E	E	E	E	U	F	E
Nickel Ammonium Sulfate	U	-	E	F	U	-	-	-	-	E	-	-	-	-	-
Nickel Chloride	U	-	G	G	U	G	E	E	E	E	E	E	E	E	-
Nickel Sulfate 10% 60° F (16° C)	U	-	E	G	G	E	E	E	E	E	E	E	E	G	-
Nitric Acid 10% 70° F (21° C)	U	-	G	U	U	G	G	U	U	G	E	E	G	U	U
Nitric Acid 30% 70° F (21° C)	U	-	G	U	U	G	G	U	U	F	E	E	G	U	U
Nitric Acid 60% 175° F (79° C)	U	-	G	U	U	G	G	U	U	U	U	E	U	U	U
Nitric Acid 70%	U	U	G	U	U	G	G	U	U	U	U	E	U	U	U
Nitrobenzene	U	-	E	G	-	E	-	F	U	U	U	G	U	-	U
Oils and Fats	E	E	E	G	E	E	-	-	E	-	-	U	U	-	E
Oils, Fish	U	G	E	-	F	E	-	-	G	E	F	U	U	-	E
Oleic Acid 100° F (38° C)	U	F	G	G	G	E	E	E	F	G	G	G	-	U	G
Oleum (Fuming Sulfuric Acid)	U	U	F	-	-	G	G	-	U	U	U	E	U	U	U
Oxalic Acid	U	F	G	F	F	G	G	F	G	G	G	E	G	U	F
Oxygen	E	E	E	E	E	E	-	E	G	E	E	E	E	-	G
Ozone	U	G	E	-	-	-	-	E	U	F	E	E	E	U	G
Palmitic Acid	U	G	E	G	G	E	-	E	E	G	F	G	G	F	G
Perchlorethylene	F	G	E	G	G	E	-	E	F	U	U	E	U	U	F
Petroleum – Refined	G	-	E	E	E	-	-	E	E	G	E	E	U	U	E
Petroleum – Sour	U	G	G	G	F	G	E	E	F	-	E	G	U	-	G
Phenol	U	-	E	E	G	E	E	E	U	U	U	G	-	U	F
Phosgene	-	-	E	-	-	-	-	-	G	U	U	G	U	U	-
Phosphoric Acid 10% 70° F (21° C)	U	F	G	F	U	G	E	E	G	G	G	E	G	F	-
Phosphoric Acid 25% 70° F (21° C)	U	U	G	F	U	G	G	E	F	G	G	E	E	U	-
Phosphoric Acid 75% 70° F (21° C)	U	U	G	F	U	-	F	E	U	G	G	G	E	U	-
Phosphorous Oxchloride	U	-	-	-	-	-	-	-	-	-	-	-	-	-	-

* See material trademark note on page 40.

Rating Interpretation	Stem and Disc								Seat						
	Nickel-Plated Ductile Iron	416 SS	316 SS	Monel*	Aluminum Bronze	Alloy 20	Hastelloy C*	PVF	Buna-N	Neoprene	Hypalon*	FKM	EPDM	Natural Rubber	ETM-30230
Pickling Sol. (20% Nitric to 4% HF)	U	-	G	G	-	-	-	-	U	U	U	G	F	U	U
Picric Acid 80% 70° F (21° C)	U	-	G	U	-	E	E	E	G	E	E	G	E	G	-
Polyethylene Glycol Dimethyl Ether (Selexol)	-	-	-	-	-	-	-	-	-	-	-	U	G	U	-
Potassium Chloride	U	-	G	G	E	E	-	E	E	E	E	E	E	E	E
Potassium Cyanide	F	G	G	G	U	E	-	E	E	E	E	E	E	E	E
Potassium Hydroxide 5% 70° F (21° C)	F	G	E	E	U	E	E	G	E	G	E	G	E	G	-
Potassium Nitrate 6% 68° F (20° C)	F	G	E	G	F	E	E	E	E	E	G	E	E	E	E
Potassium Phosphate	U	-	G	G	F	-	-	-	E	E	-	E	-	-	-
Potassium Sulfate 7% 180° F (82° C)	F	G	E	E	E	E	-	E	E	E	G	E	E	-	E
Potassium Sulfide	U	G	E	F	U	E	-	E	E	G	G	G	G	G	-
Potassium Sulfite	U	-	E	-	-	E	-	-	E	G	G	E	E	G	-
Propane	F	E	E	E	E	E	-	E	E	G	G	E	U	U	E
Resins and Rosins	U	E	E	G	E	E	E	-	F	F	F	E	-	F	-
SAE #10 Oil	G	-	-	-	E	-	-	-	E	-	E	E	U	-	E
Sea Water 70° F (21° C)	U	F	G	E	E	G	E	E	E	E	E	G	E	F	-
Sewage	U	G	E	G	G	E	-	E	E	E	E	E	G	F	-
Silicate Ester Synthetic Oil	-	-	-	-	-	-	-	-	-	G	E	E	U	-	-
Skydrol 500	G	E	E	-	E	E	-	-	U	U	U	U	E	U	U
Soap Solution (Stearate) 70° F (21° C)	U	F	E	E	E	E	E	E	E	E	E	E	E	F	E
Sodium Acetate 5% 75° F (24° C)	U	F	E	G	G	E	E	E	G	G	U	U	E	E	-
Sodium Aluminate	U	-	E	G	G	E	-	-	E	E	G	E	G	G	-
Sodium Bisulfate	U	F	E	-	-	E	-	E	E	E	E	E	E	E	E
Sodium Carbonate 80% 60° F (16° C)	U	G	E	E	G	E	E	E	E	E	E	E	E	E	E
Sodium Chloride 30% 180° F (82° C)	U	F	E	E	E	E	E	E	E	E	E	E	E	E	E
Sodium Cyanide	U	-	G	U	U	E	-	E	E	E	E	E	E	E	-
Sodium Fluoride 5% 60° F (16° C)	U	-	G	G	F	-	E	E	E	E	G	E	G	G	-
Sodium Hydroxide 5%	U	G	E	G	F	E	E	G	G	F	E	G	E	E	-
Sodium Hydroxide 20%	U	F	E	E	F	E	E	G	G	U	E	G	E	E	-
Sodium Hydroxide 50%	U	F	G	G	U	E	E	E	G	U	G	F	G	G	-
Sodium Hydroxide 70%	U	U	F	F	U	G	G	G	F	U	U	U	G	F	-
Sodium Hypochlorite 5% 60° F (16° C)	U	-	G	G	U	G	E	E	F	U	E	E	G	F	G
Sodium Nitrate 30% 60° F (16° C)	U	G	E	G	G	E	E	E	G	G	E	E	E	G	G
Sodium Perborate	U	G	G	G	G	-	-	-	G	G	G	E	E	G	-
Sodium Peroxide	U	G	E	G	U	-	-	E	G	G	G	E	E	G	-
Sodium Phosphate 5% 60° F (16° C)	U	G	E	G	F	E	E	E	E	G	E	E	E	E	U
Sodium Silicate	U	G	E	G	G	E	E	E	E	E	E	E	E	E	-
Sodium Sulfate 80% 60° F (16° C)	U	G	E	G	G	E	E	E	E	E	E	E	E	G	E
Sodium Sulfide 70% 70° F (21° C)	U	G	E	-	-	E	E	E	E	E	E	E	E	G	-
Sodium Sulfite 5% 70° F (21° C)	U	-	E	G	U	E	E	E	E	E	E	E	E	G	-
Steam 225° F (107° C)	U	U	E	E	E	-	-	-	U	U	U	U	G	U	U
Steam 300° F (149° C)	U	U	E	E	G	-	-	-	U	U	U	U	U	U	U
Stearic Acid 90% 200° F (93° C)	U	G	E	E	F	E	E	E	G	G	G	E	G	G	F
Steep Water	-	-	-	-	-	-	-	-	-	-	G	G	-	U	-
Styrene (Fumes)	-	-	E	-	-	-	-	-	U	-	-	G	U	-	-
Sulfamic Acid	-	-	-	-	-	E	-	E	-	-	E	-	G	-	-
Sulfur (Molten)	U	F	G	U	U	E	E	-	U	F	U	G	F	U	F
Sulfur Dioxide 60° F (16° C)	U	G	E	E	F	E	E	E	U	G	F	E	E	G	-
Sulfur Trioxide	U	G	E	-	-	E	E	-	U	U	U	E	G	G	-
Sulfuric Acid 0% to 7% 70° F (21° C)	U	F	G	F	U	E	E	E	U	G	E	E	U	U	F
Sulfuric Acid 7% to 40% 70° F (21° C)	U	U	U	U	U	G	G	E	U	U	E	E	U	U	-
Sulfuric Acid 40% to 75% 70° F (21° C)	U	U	U	U	U	G	G	E	U	U	G	G	U	U	-
Sulfuric Acid 75% to 95%	U	U	U	U	U	U	G	E	U	U	U	G	U	U	-
Sulfuric Acid 95% to 100%	U	U	U	U	U	U	E	E	U	U	G	G	U	U	U
Sulfurous Acid 80% 100° F (38° C)	U	U	G	F	U	E	E	G	U	U	E	E	U	-	-

* See material trademark note on page 40.

MATERIAL SELECTION GUIDE (CONT.)

Rating Interpretation E – Excellent G – Good F – Fair U – Unsatisfactory	Stem and Disc								Seat						
	Nickel-Plated Ductile Iron	416 SS	316 SS	Monel*	Aluminum Bronze	Alloy 20	Hastelloy C*	PVF	Buna-N	Neoprene	Hypalon*	FKM	EPDM	Natural Rubber	ETM-30230
Tall Oil	G	G	E	G	-	E	-	E	G	G	-	E	-	E	-
Tannic Acid 150° F (66° C)	U	F	E	G	G	E	E	G	E	G	G	E	E	E	F
Tar	F	E	E	E	E	E	E	-	F	F	-	E	U	E	F
Tartaric Acid 150° F (66° C)	U	G	E	G	G	E	E	G	G	G	E	E	G	E	F
Toluol and Toluolene	G	E	E	-	E	E	-	G	U	U	U	E	U	U	U
Toluene Sulfonic Acid	-	-	U	-	-	-	-	U	-	-	-	G	-	-	-
Transformer Oil	-	-	-	-	-	-	-	-	U	-	-	E	U	-	-
Tributyl Phosphate	G	F	E	-	-	E	-	E	U	U	U	E	E	G	-
Trichloroacetic Acid	U	U	U	G	G	-	-	F	G	U	U	F	G	F	-
Trichloroethylene	F	U	E	G	G	E	-	G	U	U	U	E	U	U	U
Triethinolamine	U	U	E	G	-	-	-	G	F	E	E	U	G	G	-
Trisodium Phosphate	U	U	G	G	F	-	-	E	F	F	-	-	-	-	-
Tung Oil	U	U	E	F	E	E	E	-	E	G	G	E	U	U	-
Turpentine	U	U	E	G	G	-	-	E	G	U	U	E	U	U	F
Vinegar 70° F (24° C)	U	-	E	E	-	E	E	G	G	G	E	E	E	G	-
Water, Acid – Mine	U	-	E	U	-	E	E	G	F	F	E	E	F	F	-
Water – Deionized	-	-	E	-	-	-	-	E	E	-	E	-	E	-	-
Water – Demineralized	U	-	E	E	E	E	-	E	E	E	E	E	E	F	-
Water – Fresh 180° F (82° C)	G	E	E	E	E	E	E	E	G	G	F	U	E	U	F
Water – Fresh 225° F (107° C)	G	E	E	E	E	E	E	E	U	U	U	U	E	U	-
Water – Salt 180° F (82° C)	U	U	G	E	G	E	E	E	G	G	F	U	E	U	-
Water – Sewage 80° F (27° C)	U	G	E	E	E	E	E	-	E	-	-	E	E	-	-
Whiskey and Wine	U	U	E	E	G	E	E	E	E	E	G	E	E	-	-
White Liquor	U	-	E	-	-	E	E	-	G	-	G	-	-	F	-
Xylene, Xylol	F	E	E	-	E	E	-	E	U	U	U	E	U	U	U
Zinc Chloride 5% 160° F (71° C)	U	U	F	G	U	G	G	E	E	E	E	E	E	E	-
Zinc Phosphate	-	-	G	-	-	-	-	E	E	-	-	-	E	-	-
Zinc Sulfate 25% 180° F (82° C)	U	G	E	G	G	E	E	E	E	E	E	E	E	G	-

* See material trademark note on page 40.

For proper valve repair, use genuine DEMCO replacement parts.

Services for Valves and Actuation

WE BUILD IT. WE BACK IT.

Startup and Commissioning

Our experts understand that each project is unique. That's why Cameron's service team helps facilitate commissioning and start-up activities.

- Integrated solutions, onsite or at our global service centers
- Increased equipment and product performance
- The shortest possible trouble-free startup for your critical assets

Spare Parts and Asset Management

Cameron offers the assets and expertise to cover all aspects of valve management.

- Full inventory of quality exact OEM parts and spares
- Complete asset risk and criticality assessments
- Comprehensive inventory of your assets, including a complete recommended spare valves and parts list

Operational Support

Cameron's ability to address valve requirements in the field is a reflection of our commitment to life-of-asset support.

- Innovative asset management solutions
- Trouble-free installation, startup and operations
- Support from commission to operation – extending through all phases of a valve's life cycle
- Extensive inventory of spare valves and parts

Cameron's site management team helps mitigate the risk of project delays by identifying issues in the construction process prior to valve installation to ensure valve integrity.



Trademark Information

DEMCO is a registered trademark of Cameron.

This document contains references to registered trademarks or product designations, which are not owned by Cameron.

Trademark	Owner
CELCON	Hoechst Celanese Corporation
DELRIN	E.I. DuPont De Nemours & Company
FLUOREL	Minnesota Mining and Manufacturing Company
HASTELLOY	Haynes International, Inc.
HYCAR	Hydrocarbon Chemical and Rubber Company
HYDRIN	Zeon Chemicals USA, Inc.
HYPALON	E.I. DuPont De Nemours & Company
INCONEL	INCO Nickel Sales, Inc.
MONEL	INCO Alloys International, Inc.
NORDEL	E.I. DuPont De Nemours & Company
STELLITE	Stoody Deloro Stellite, Inc.
TEFLON	E.I. DuPont De Nemours & Company

CERTIFICATIONS





3250 Briarpark Drive, Suite 300

Houston, TX 77042

USA

Toll Free 1 800 323 9160

Learn more about DEMCO butterfly valves:

www.c-a-m.com/DEMCO

DEMCO@c-a-m.com



HSE Policy Statement

At Cameron, we are committed ethically, financially and personally to a working environment where no one gets hurt and nothing gets harmed.