

PRODUCT INSTRUCTIONS

Type 70 Pressure Regulator

INSTALLATION:

The Bellofram high-flow Type 70 is designed for air service only. The maximum supply pressure is 250 PSI.

Clean all pipe line to remove dirt and scale before installation is made. Apply minimum amount of pipe compound to male threads of air line only. Install regulator in air line; body is fitted with a 1/4", 3/8" or 1/2" NPT for inlet and outlet connections. The words "IN" and "OUT" are cast into body to indicate the direction of flow. Regulator can be mounted in any position without affecting its operation. Avoid undersized fittings that will limit flow through the regulator and cause pressure drop downstream. The use of a filter to remove dirt and liquid in the air line ahead of the regulator is recommended for best performance. If an air line lubricator is used, it should be located downstream beyond the regulator in order to avoid interference with the regulator performance.

OPERATION:

The Type 70 is a high capacity regulator that provides a uniform output pressure independent of supply pressure variations.

Before putting the regulator into service for the first time, relieve pressure on the range spring by turning the knob counterclockwise. To operate, turn the pressure adjusting knob slowly in a clockwise direction until required downstream pressure is obtained. Turned in this direction, the range spring compresses causing increased output pressure.

MAINTENANCE:

The regulator is easily disassembled for the occasional cleaning or removal of foreign matter. Before this is done, however, shut off valve upstream of the regulator to prevent escape of air when regulator is disassembled. There is no need to remove the regulator from the pipe line; remove the two 8-32 screws on the bottom of the unit and pull out the pintle assembly. Wash inner valve assembly with solvent exercising care to avoid damaging diaphragms and valve facings. (Avoid such solvents as acetone, carbon tet, trichlorethlene.) Replace assembly carefully.

The vent hole in the bonnet should be kept clear. A slight flow of air through this hole is necessary for the proper operation of the regulator.

TO INSTALL REPLACEMENT PARTS:

1. Order repair kit. See back of this sheet.
2. Shut off air supply.
3. To replace "O"-ring and pintle assembly, see disassembly instructions above under "Maintenance".
4. To replace diaphragm assembly.
 - a. Remove knob assembly, (6) 8-32 screws securing bonnet, guide, range spring and diaphragm assembly.
 - b. Install diaphragm assembly and other parts in reverse order. Be sure to align bonnet vent hole with the "IN" port.

Warranties of Sale, disclaimer thereof and limitations of liability are covered exclusively by Bellofram's printed warranty statement for the regulators. These instructions do not expand, reduce, modify or alter Bellofram's warranty statement and no warranty or remedy in favor of a customer or any other person arises out of these instructions.

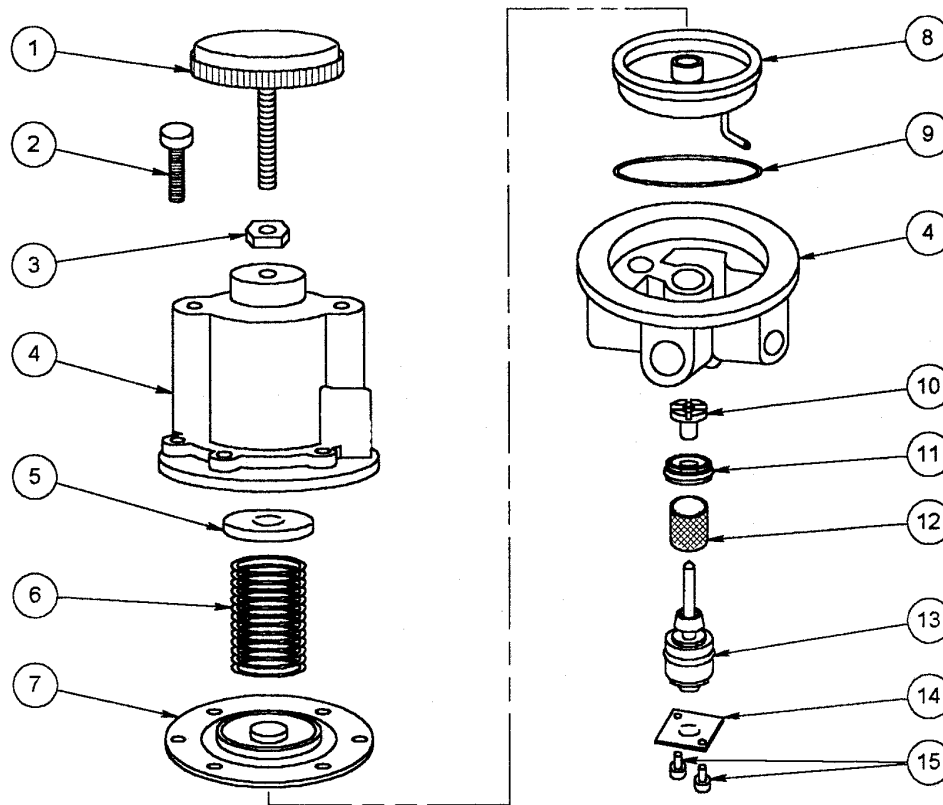

ITEM	PART NUMBER	QTY.	DESCRIPTION
1	218-630-000-004	1	Knob Assembly
2	214-648-000-145	6	8-32 X 7/8" Screws
3	214-634-000-054	1	5/16-24 Nut
4		1	(Order entire Pressure Regulator)
5	214-626-000-026	1	Spring Guide 0-30 1-60 PSIG
5	216-643-000-072	1	Spring Guide 2-150 PSIG
6	214-655-000-132	1	Range Spring 0-30 PSIG
6	214-655-000-131	1	Range Spring 1-60 PSIG
6	214-655-000-133	1	Range Spring 2-150 PSIG
7	222-804-000-023	1	* Diaphragm Assembly
8	212-814-000-005	1	Baffle Assembly
9	214-649-000-201	1	"O"-Ring
10	214-626-000-027	1	Lower Baffle Guide
11	212-650-000-019	1	Seat Assembly
12	214-647-000-005	1	Screen
13	212-813-000-003	1	* Pintle Assembly
14	214-638-000-016	1	Bottom Plate
15	214-648-000-146	2	8-32 X 3/8" F.H. Screws

* Denotes parts more commonly replaced and included in repair kit.
Kit P/N 201-970-127-000

IMPORTANT: Orders for these parts cannot be properly filled unless you specify the regulator part number and pressure range.